

AC2

AUTOMATIC CONTROLLER MODULE

**OPERATING INSTRUCTIONS
and trouble-shooting guide**

LECTROSONICS, INC.

Rio Rancho, NM

INTRODUCTION

The AC2 Automatic Controller module is the heart of an automatic Modular Audio Processor installation. In addition to supplying all the power for other Modular Audio Processor system modules, it controls and meters system output levels, and provides other functions in support of the automatic functioning of the system.

All main modules (automatic or expansion) reside in a special slot on the far right side of a Modular Audio Processor mainframe. A printed circuit board inside the Modular Audio Processor mainframe serves as the bus for signals and power to be distributed within a Modular Audio Processor system. Most necessary connections between the main module and other modules are made by the main bus, leaving very little wiring to be done by the installer.

TABLE OF CONTENTS

INTRODUCTION	3
GENERAL TECHNICAL DESCRIPTION	4
FRONT PANEL DESCRIPTION	5
REAR PANEL DESCRIPTION	6
INTERNAL JUMPER SETTINGS	7
PARTS AND ACCESSORIES	7
MODULE REMOVAL AND INSTALLATION	8
OPERATING INSTRUCTIONS	8
TROUBLESHOOTING	9
SPECIFICATIONS	10
SERVICE AND REPAIR	11
RETURNING UNITS FOR REPAIR	11
WARRANTY	Back cover

GENERAL TECHNICAL DESCRIPTION

The AC2 Automatic Controller module is the "system controller" for an automatic mixing system.

The power supply for the system is located in the main module. A toroidal power transformer is used in the Modular Audio Processor system, for both lower radiated and mechanical noise. The secondaries are rectified and filtered to produce ± 23 Volts. The unregulated power is then distributed to each module, where it is regulated to ± 15 Volts.

The Modular Audio Processor system has two central signal buses, Main and Aux, which drive rear panel balanced outputs. Both of these buses are controlled via front panel level controls. In addition, the post level control output of either bus can be monitored using the front panel LED meter. The Main bus and the Aux bus are both routed through high quality voltage controlled amplifiers (VCA). This VCA is employed by the gain monitoring circuitry which reduces the main output gain by approximately 3dB for every doubling of the Number of Open Microphones. This is known as NOM attenuation, and aids sound system stability as more microphones come into active use. The NOM function may be defeated via an internal jumper setting. These VCAs also give remote level control capability to both outputs. The Main and Aux output drivers are special electronically balanced and floating high current output devices. This circuit provides most of the advantages of a transformer coupled output, and suffers none of the low frequency non-linearities of a transformer. The Main output is typically used to feed the main sound system, while the Aux output can be used as a separately controlled signal for remote sound systems or an audio feed for broadcast or recording.

Several other functions are also provided by the automatic main module. Last Mic Hold is a function which will force the microphone channel which was last active to stay on, even in the absence of signal. This is in contrast to most automatic mixers, where all channels with no activity are attenuated. This feature is particularly useful in situations where some output from the sound system is desired under all circumstances. The Last Mic Hold feature is switchable via a front panel switch.

A Threshold control provides a means to raise or lower the effective sound pressure level where the automatic channels begin to come on. This function is used to account for background noise and to set the threshold above the background noise.

Three other functions are accessible through a rear panel barrier strip. The first is the Manual Priority function. When this function is engaged, all non-priority mic channels will be attenuated. This feature is useful in situations where a chairperson, or other primary speaker, might need to forcibly restrict access to the sound system. As mentioned above, both the Main and Aux buses may be remotely controlled, using a 10K linear pot or a DC voltage. Continuous volume control over a 70dB range is available, and simple contact closures may be used if only a mute function is needed.

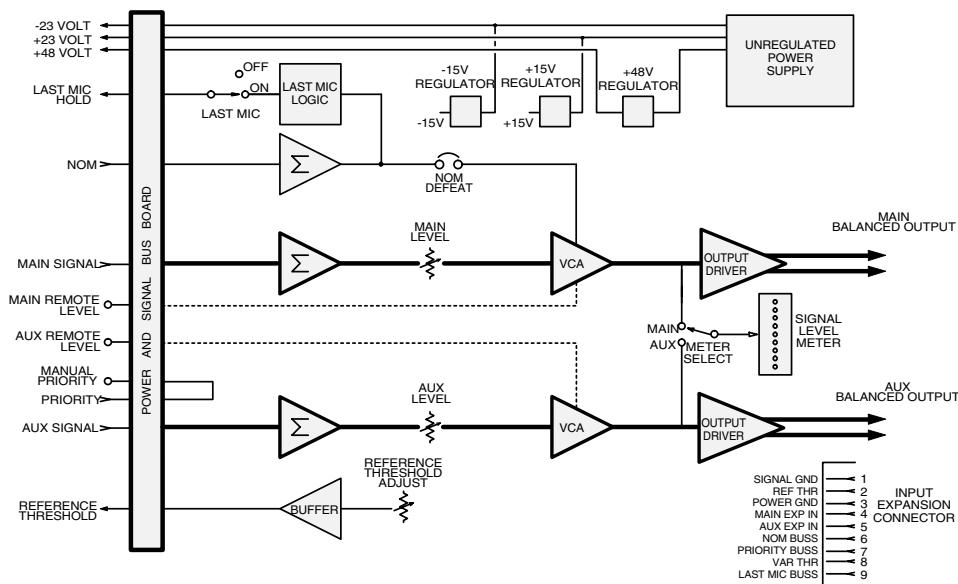

Figure 1 - AC2 Block Diagram

FRONT PANEL DESCRIPTION

POWER - Controls AC power for the module.

LAST MIC HOLD - Controls the Last Mic Hold function. When in the ON position, the last active mic channel will remain on, even when there is no signal present. In the OFF position, no channel will be open unless there is signal present.

METER - Controls the choice of output signals to be displayed on the LED meter to the left of the switch. Both the Main and Aux signals are metered after their respective level controls.

THRESHOLD - Controls the level at which the automatic channels begin to come on. In the "0" position (fully counter-clockwise), the automatic channels will be the most sensitive and tend to come on for a lower level signal. As the Threshold control is turned clockwise (toward "10"), progressively larger signals will be needed to turn the channel on.

AUX LEVEL - Controls the output level of the Aux output.

MAIN LEVEL - Controls the output level of the Main output.

OUTPUT LEVEL METER - Displays the signal level of either the Main or Aux outputs (depending on the position of the METER switch). The meter is calibrated in dBu (.775 Vrms is 0dBu). When the yellow +8 LED flashes, this indicates about 12dB of system headroom left before clipping.

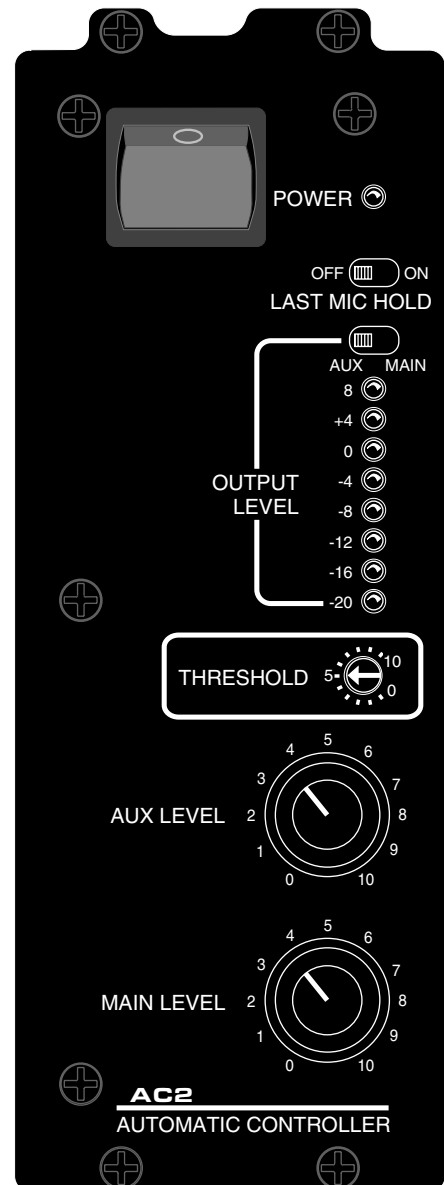

Figure 2 - AC2 Front Panel

REAR PANEL DESCRIPTION

FUSE HOLDER - Contains the AC fuse for the system. This fuse is a 3/4A Slo-Blo type, and should only be replaced by a similar type fuse.

SIGNAL GROUND SWITCH - Connects the signal to chassis ground or lets signal ground float. This feature can be helpful in tracking down and eliminating ground loops. This switch does not in any way effect the chassis connection to the third wire of the power cord: this connection is hardwired internally for safety.

MANUAL PRIORITY - Attenuates all automatic channels set in the "AUTO" mode position, irrespective of the presence of signal at those mics. To activate Manual Priority, a SPST switch can be used to make the connection between -15 Volts and Manual Priority.

MAIN/AUX REMOTE - Allows a 10K linear pot or DC voltage to control the volume level of the Main or Aux output.

AUX OUTPUT - Provides an electronically balanced and floating output signal. Output impedance is 100 Ω balanced, and 50 Ω unbalanced.

MAIN OUTPUT - Provides an electronically balanced and floating output signal. Output impedance is 100 Ω balanced, and 50 Ω unbalanced.

EXPANSION INTERFACE CONNECTOR - Provides a means of system expansion if more than one Modular Audio Processor mainframe is needed. Uses a standard male to female 9 pin subminiature D type connector.

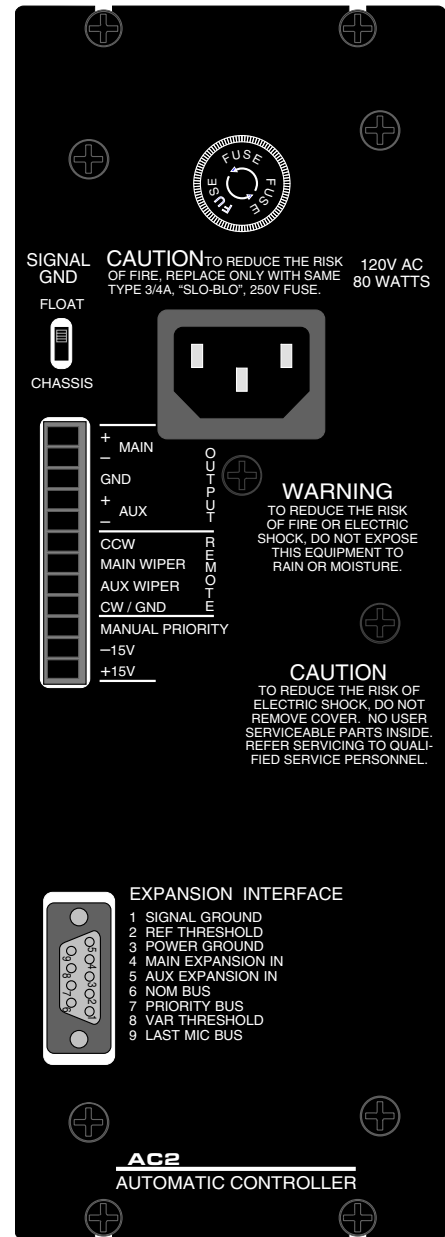

Figure 3 - AC2 Rear Panel

INTERNAL JUMPER SETTINGS

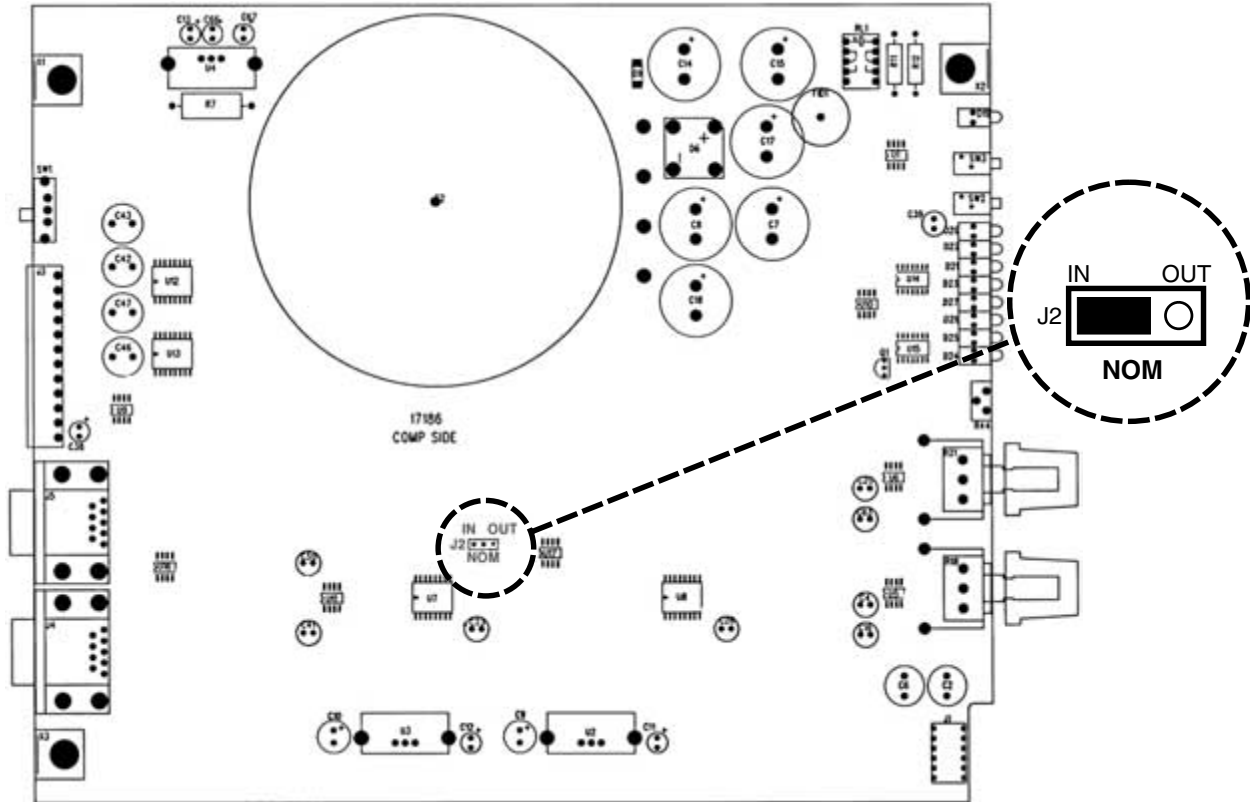

Figure 4 - Internal Jumper Settings

There is only one jumper setting on the PC Board - NOM. Moving the jumper to the OUT position (to the right) disables the NOM function.

PARTS AND ACCESSORIES

#21504	12-Pin Depluggable Connector
#21499	AC Power Cord
#21455	9-Pin D-Sub Expansion Interface Cable, 18"

MODULE REMOVAL AND INSTALLATION

Before setting up the AC2 for the first time, check the Internal Jumper Settings diagram (Figure 4). Figure 4 shows the factory default position for the NOM jumper (NOM In) . If changes are necessary, remove the AC2 module from the frame by removing the four phillips head screws on the front and the four on the back of the module (see Figure 5 below.) Slide the module out of the frame by gently pushing on the front panel of the AC2 and guiding it out of the rear. With the module removed from the Modular Audio Processor frame, remove the metal cover from the component side of the module to gain access to the internal jumper.

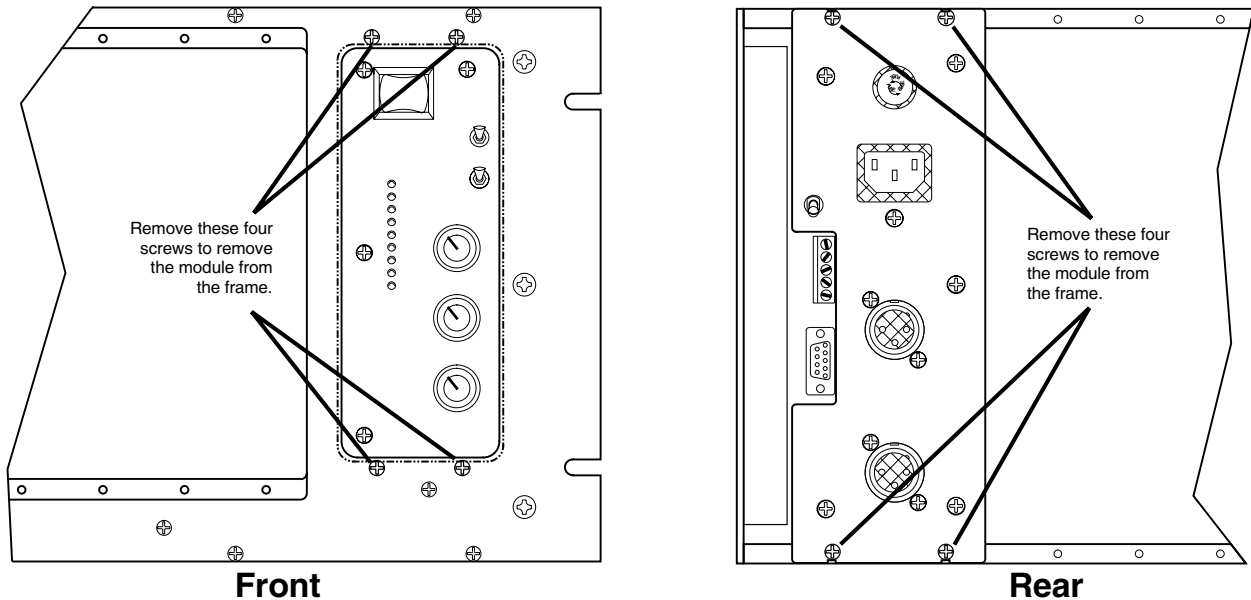

Figure 5 - Removing the module from the frame

To re-install the AC2 module, fit the module into the card guides for the slot and slide it forward in the mainframe until the female edge connector seats firmly onto the male pins of the main bus board.

Care should be taken when inserting the edge connector onto the pins to be sure there is correct alignment.

Four phillips head #2 machine screws with captive washers are provided to secure the rear panel of the AC2 to the top and bottom rear rails of the Modular Audio Processor mainframe. Four #2 flat head screws are provided to secure the front panel of the AC2 to the front panel of the Modular Audio Processor mainframe. Once these eight screws are in place, the installation of this module is complete.

OPERATING INSTRUCTIONS

The following instructions assume a system with automatic mic preamp modules. Further, these instructions assume proper setup of the automatic mic preamp module, in accordance with the instructions provided with that module. Note that standard mic preamp modules will function perfectly well with an automatic main module, with the obvious exception of the lack of the automatic features of operation.

- 1) Set the THRESHOLD control until ambient noise causes only the slightest flicker in the green ON LEDs (found on the automatic mic preamp front panels). It is best to start with the THRESHOLD control in the "0" position and increase as necessary. This will yield the most sensitive setup without undue interference from ambient noise. If this setting is found to be too sensitive, the threshold control can be increased further. After this initial adjustment, have someone speak into a microphone at an average level. The green ON LED (on the automatic preamp) should glow brightly most of the time the speaker is speaking.

- 2) Set the LAST MIC HOLD switch to the desired position. Unless there is some reason to the contrary, most systems can benefit from having the LAST MIC HOLD function ON.
- 3) Set the METER switch to the desired position. If under normal conditions of use the meter indication is very low, it is possible to turn down the sensitivity of the power amplifier(s) driving the system and increase the Main or Aux level to give more meter indication.
- 4) Set the AUX LEVEL control to the desired level (or to "0" if the Aux output is not being used).
- 5) Set the MAIN LEVEL control to the desired level.
- 6) If the MANUAL OVERRIDE is desired, a SPST switch must be connected between -15 VOLTS and MANUAL PRIORITY. When the switch is closed, all mic preamp channels set in the "AUTO" mode position will be attenuated until the switch is open. Note that the MANUAL PRIORITY will not effect channels in either the "PRIORITY" or "DIRECT" mode position. Also be aware that the MANUAL PRIORITY has no effect on AUX output signals.
- 7) If REMOTE volume control is desired, connect either a 10K linear pot or a DC voltage source to the appropriate REMOTE terminals. When using a pot, simply connect the counterclockwise pot lead to the REMOTE CCW terminal, the clockwise pot lead to the REMOTE CW/GND terminal, and the pot wiper lead to the REMOTE MAIN WIPER or the REMOTE AUX WIPER, depending on whether the Main or Aux bus is to be controlled. If a DC control voltage is used, the needed range is 0VDC to +15VDC. This voltage range corresponds to 0dB to 70dB attenuation. The control voltage source ground should be connected to the REMOTE CW/GND terminal, and the control voltage source hot lead should be connected to the desired REMOTE WIPER terminal. Note that the attenuation goes from 0dB to 20dB as the control voltage goes from 0VDC to 7.5VDC, and from 20dB to 70dB as the control voltage goes from +7.5VDC to +15VDC.
- 8) In the unlikely event of a ground loop, the rear panel SIGNAL GROUND switch can be used to lift signal ground from chassis ground to facilitate finding the cause of the ground loop. Normally, the signal ground should be connected to chassis ground.

TROUBLESHOOTING

SYMPTOM	POSSIBLE CAUSE
1) No POWER LED	1) Power switch not on 2) Unit not plugged in
2) No sound from Main output	1) MAIN LEVEL control turned down 2) Channel level controls on mic preamps not turned up 3) THRESHOLD control set to high (check channel ON LEDs on mic preamps) 4) INPUT TRIM controls on preamp channels too low (Note: Does not apply to LP4 Preamp module.)
3) No sound from Aux output	1) AUX LEVEL control turned down 2) INPUT TRIM controls on preamp channels too low (Note: Does not apply to LP4 Preamp module.)
4) No OUTPUT LEVEL meter	1) METER switch in wrong indication position 2) MAIN or AUX level controls turned down

SPECIFICATIONS

Maximum Gain:	20dB (Maximum total system gain is 80dB with LP4 preamp module)
THD @ +4dBu, 20-20kHz:	Less than 0.05% (Measured from Aux or Main expansion input)
IMD @ +4dBu, 60/7kHz:	Less than 0.05% (Measured from Aux or Main expansion input)
Noise:	
Main Output: (20Hz-20kHz)	-85dBu with Main level at minimum -83dBu with Main level at unity gain -80dBu with Main level at unity and one channel at 40dB gain, terminated with 150Ω
Aux Output: (20Hz-20kHz)	-85dBu with Aux level at minimum -83dBu with Aux level at unity gain -80dBu with Aux level at unity and one channel at 40dB gain, terminated with 150Ω
Maximum Output Level:	+20dBu for loads greater than 2KΩ, balanced or unbalanced
Outputs:	
MAIN and AUX: Type:	Electronically balanced and floating, RF Filtered
Output Impedance:	100Ω balanced 50Ω unbalanced
Remote Inputs:	
Input Resistance:	100KΩ
Attenuation Range:	70dB
Input Voltage Range:	0-15 VDC
Manual Priority Input:	
Type:	Needs switch closure to -15 VDC to operate
Maximum Power Consumption:	0.75 Amps at 120VAC 90 Watts

SERVICE AND REPAIR

If your system malfunctions, you should attempt to correct or isolate the trouble before concluding that the equipment needs repair. Make sure you have followed the setup procedure and operating instructions. Check out the inter-connecting cords and then go through the TROUBLE SHOOTING section in the manual

We strongly recommend that you **do not** try to repair the equipment yourself and **do not** have the local repair shop attempt anything other than the simplest repair. If the repair is more complicated than a broken wire or loose connection, send the unit to the factory for repair and service. Don't attempt to adjust any controls inside the units. Once set at the factory, the various controls and trimmers do not drift with age or vibration and never require readjustment. **There are no adjustments inside that will make a malfunctioning unit start working.**

LECTROSONICS service department is equipped and staffed to quickly repair your equipment. In-warranty repairs are made at no charge in accordance with the terms of the warranty. Out of warranty repairs are charged at a modest flat rate plus parts and shipping. Since it takes almost as much time and effort to determine what is wrong as it does to make the repair, there is a charge for an exact quotation. We will be happy to quote approximate charges by phone for out of warranty repairs.

RETURNING UNITS FOR REPAIR

You will save yourself time and trouble if you will follow the steps below:

- A. DO NOT return equipment to the factory for repair without first contacting us by letter or by phone. We need to know the nature of the problem, the model number and the serial number of the equipment. We also need a phone number where you can be reached 8 am to 4 pm (Mountain Standard Time).
- B. After receiving your request, we will issue you a return authorization number (R.A.). This number will help speed your repair through our receiving and repair departments. The return authorization number must be clearly shown on the outside of the shipping container.
- C. Pack the equipment carefully and ship to us, shipping costs prepaid. If necessary, we can provide you with the proper packing materials. UPS is usually the best way to ship the units. Heavy units should be "double-boxed" for safe transport.
- D. We also strongly recommend that you insure the equipment, since we cannot be responsible for loss of or damage to equipment that you ship. Of course, we insure the equipment when we ship it back to you.

Mailing address:
Lectrosonics, Inc.
PO Box 15900
Rio Rancho, NM 87174
USA

Shipping address:
Lectrosonics, Inc.
581 Laser Rd.
Rio Rancho, NM 87124
USA

Telephones:
(505) 892-4501
(800) 821-1121
FAX: (505) 892-6243

World Wide Web: <http://www.lectrosonics.com>

email: sales@lectrosonics.com

LIMITED ONE YEAR WARRANTY

The equipment is warranted for one year from date of purchase against defects in materials or workmanship provided it was purchased from an authorized dealer. This warranty does not cover equipment which has been abused or damaged by careless handling or shipping. This warranty does not apply to used or demonstrator equipment.

Should any defect develop, we will, at our option, repair or replace any defective parts without charge for either parts or labor. If we cannot correct the defect in your equipment, we will replace it at no charge with a similar new item. We will pay for the cost of returning your merchandise to you.

This warranty applies only to items returned to us, shipping costs prepaid, within one year from the date of purchase.

This warranty gives you specific legal rights. You may have additional legal rights which vary from state to state.

LECTROSONICS, INC.

**581 LASER ROAD
RIO RANCHO, NM 87124 USA**

August 17, 1996