

AV 62

AUDIO VISUAL MIXER

OPERATING INSTRUCTIONS and trouble-shooting guide

LECTROSONICS, INC.
Rio Rancho, New Mexico - U.S.A.

INTRODUCTION

The AV62 Audio Visual Mixer is an audio mixer with 6 stereo line level inputs and 2 microphone inputs in a single rack space. The AV62 offers remote control of both the stereo program output and the mono output. In addition, up to 6 user configurable memories may be stored in the AV62, and recalled with contact closures. The AV62 has an RS-232 port for remote set-up or control by a computer or other RS-232 compatible controller. The AV62 may be coupled with AM8s and/or TH2s to provide added microphone inputs or teleconferencing capability.

Table of Contents

INTRODUCTION	2
GENERAL TECHNICAL DESCRIPTION	3
INSTALLATION	4
FRONT PANEL DESCRIPTION	6
REAR PANEL DESCRIPTION	7
OPERATING INSTRUCTIONS	8
REMOTE LEVEL CONNECTIONS	9
TROUBLESHOOTING	9
SERVICE AND REPAIR	10
RETURNING UNITS FOR REPAIR	10
SPECIFICATIONS	11
SERIAL CABLE WIRING DIAGRAM	12
AMX CABLE WIRING DIAGRAM	12
AMX Programming Notes	12
SERIAL PORT COMMANDS AVAILABLE	13
FCC PART 15 NOTICE	18
WARRANTY	Back cover

GENERAL TECHNICAL DESCRIPTION

The AV62 uses a straightforward analog signal path to provide excellent audio performance. Enhanced signal routing and mixing capability make the AV62 far more versatile than a simple routing switcher. For example, line level sources may be mixed together for multi-media presentations.

Figure 1 shows the simplified block diagram of the AV62. Each line level input has individually controllable input gain. The individual left and right line inputs are mixed after the input gain control. The left and right signals then pass through a stereo tone control. From there, the signals are distributed to the various outputs according to the user's setup.

The microphone preamp is a low-noise discrete design, which is extensively RF protected. The preamp has three gain settings. The 0dB setting allows an input to accept line level signals, while the +30dB and +50dB gain settings accommodate both low and high sensitivity microphones. 15V Phantom power is provided for each channel, and is always active. The two mic inputs have individual level controls. The post level control signals are summed, and passed on to the tone control circuitry. From there, the signals are distributed to the various outputs according to the user's setup.

Six Line In Select pushbuttons allow line level audio sources to be selected when the AV62 is in the Local mode. The AV62 may be programmed to allow only one audio source at a time or any number of audio sources. Six Remote Line/Memory Select terminals are available on the rear panel 9 pin D-Sub connector that replicate the function of the front panel pushbuttons for remote control applications. In addition, both the Program and Mono output levels may be individually remotely controlled using a 10K linear pot.

Signals from the Expansion In and Expansion Out connectors allow an AV62 to be combined with one or more AM8s if more than 2 microphone inputs are necessary for the application. Special circuitry in the AV62 allows its microphone inputs to function as automatic mics when combined with AM8s. In addition, a Mix Minus signal is available which allows easy interfacing to the TH2 or other teleconferencing hybrids.

An RS-232 port is available to allow many of the functions of the AV62 to be controlled either by a computer or a dedicated control system (such as the AMX or Crestron systems).

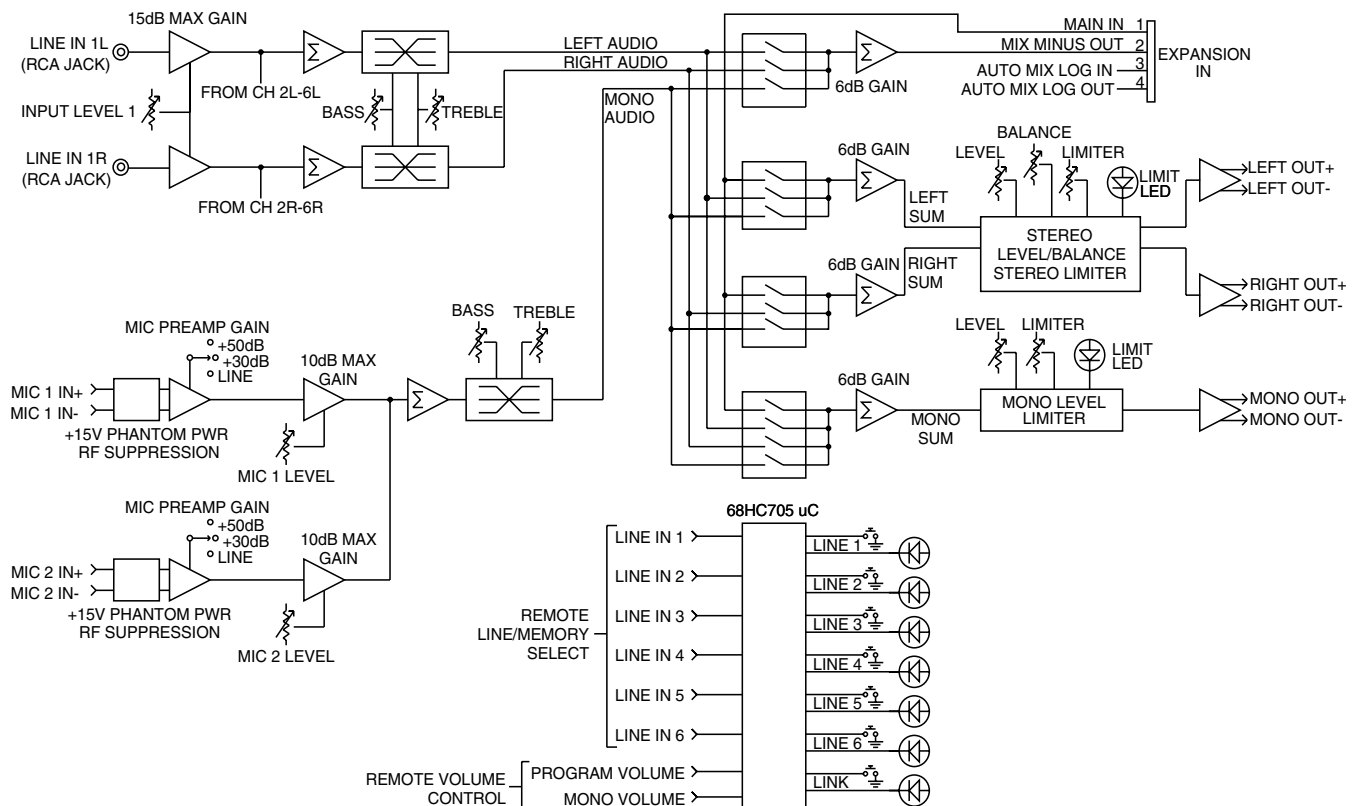

Figure 1 - AV62 Block Diagram

INSTALLATION

Installing the AV62 properly is simple, and only requires attention to a few issues. The AV62 should be used in a grounded metal rack. If one or more AM8s are to be used with the AV62, the AM8s should all be set to the **Slave** mode, and connected to the AV62 as shown below in Figure 2. Figure 3 shows the correct interconnection of an AV62 and a TH2.

**Multi-Mic AV62 System
AV62 + AM8(s)**

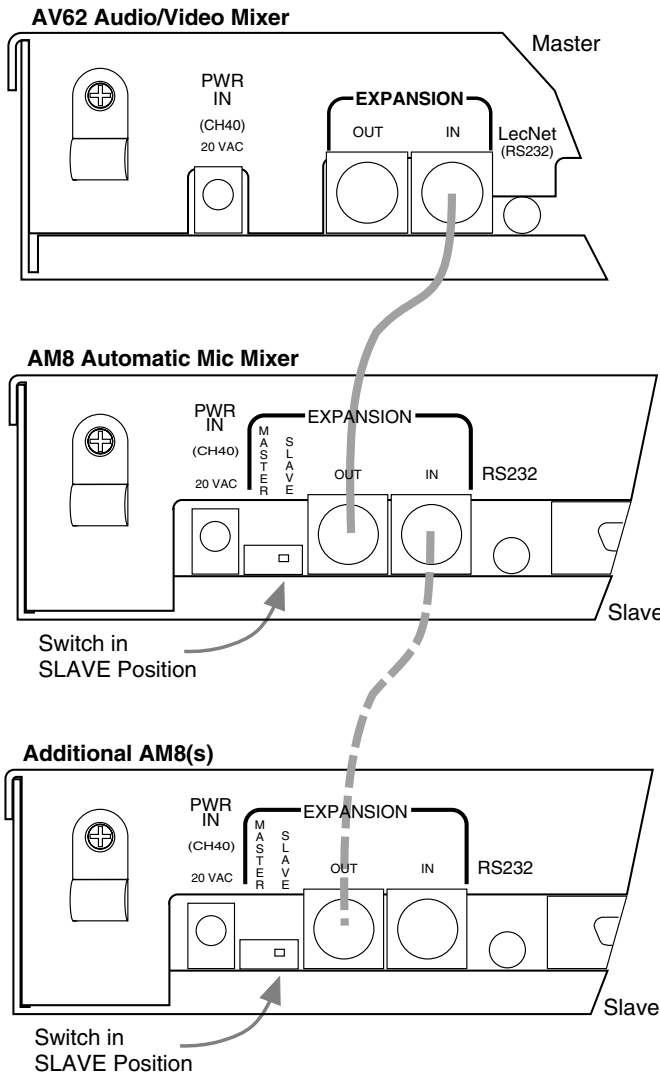

Figure 2

**Basic Teleconferencing System
AV62 + TH2**

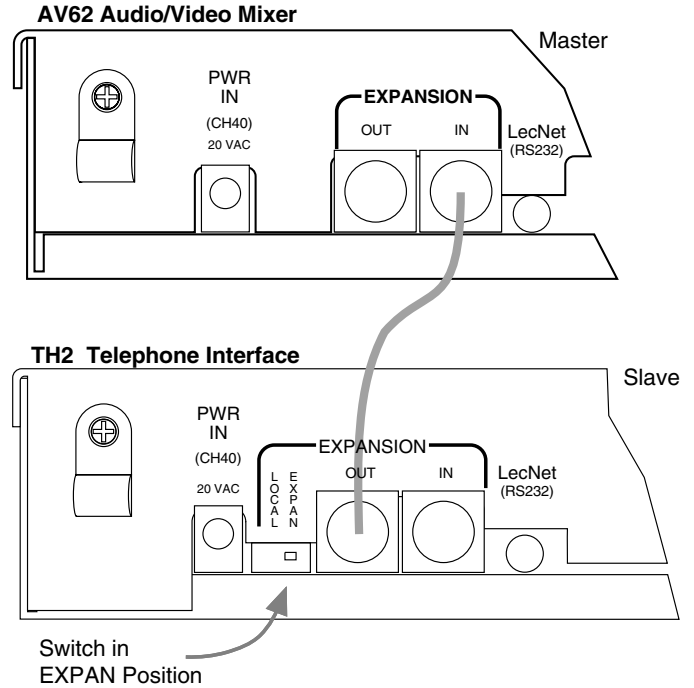

Figure 3

Microphone connections should be made with good quality braid or foil shielded twisted pair. The shield should be used for the ground (Pin 1) connection. If an unbalanced signal is used, the unbalanced signal lead should be connected to the "+" input terminal, while the unbalanced ground lead should be connected to both the "-" and ground terminals of the input connector. Line level connections are made using standard RCA style unbalanced cables.

**Multi-Mic Teleconferencing System
AV62 + AM8 + TH2**

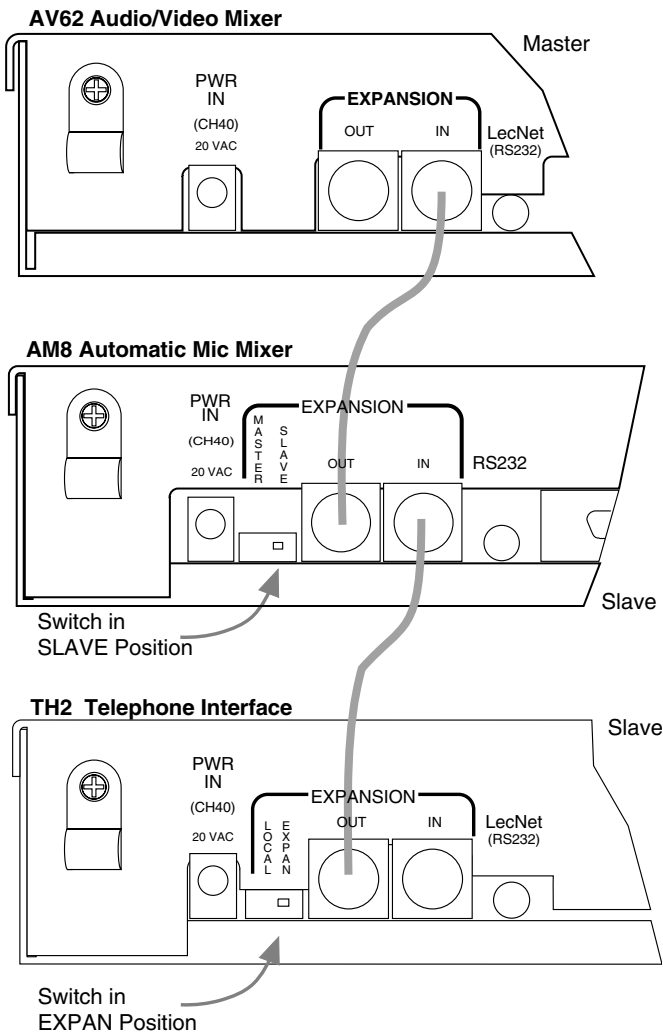

Figure 4

**Extra Mix for Recording/Auditory Assist
AV62 + TA1**

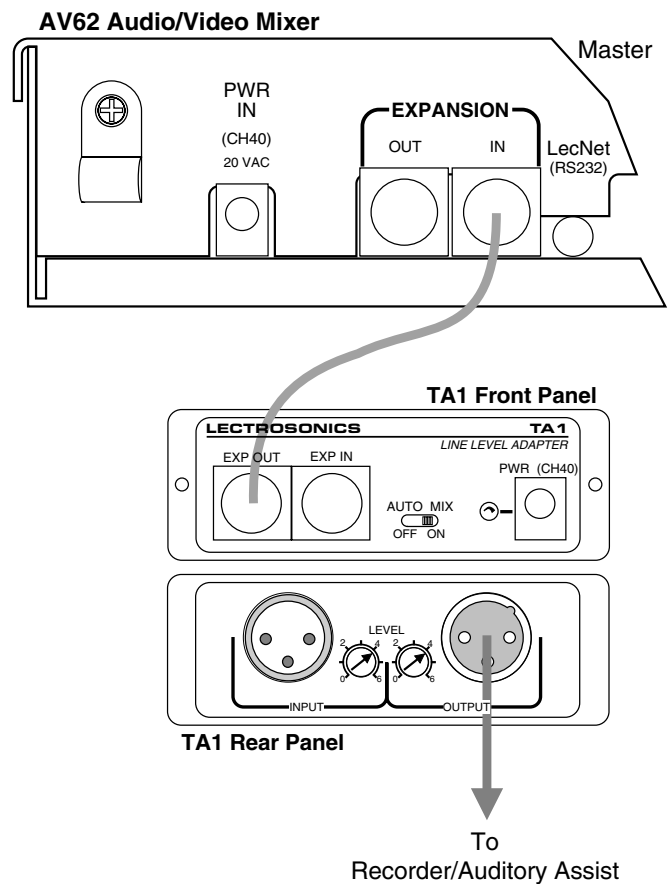

Figure 5

Output connections to the **Program Out** or **Main Out** connectors can be made balanced or unbalanced. If an unbalanced connection is desired, simply connect the unbalanced signal lead to the "+" output terminal, and the unbalanced ground lead to the output ground terminal. **Leave the "-" output terminal unconnected.**

Access to the **Remote Level Control** port is accomplished using the DB-9 connector (supplied) see REMOTE LEVEL CONNECTIONS on page 9.

FRONT PANEL DESCRIPTION

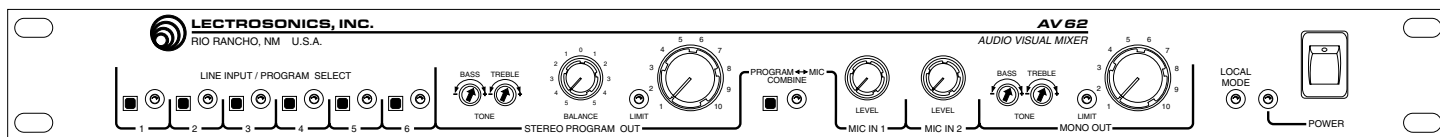

Figure 6 - AV62 Front Panel

PROGRAM AUDIO SECTION

LINE INPUT/MEMORY SELECT - Local Mode: Selects one (or more) line level inputs to be included in the program audio mix. The LED adjacent to the button will illuminate when that channel is selected. The AV62 is in Local mode when the Local Mode LED (just to the left of the Power LED) is illuminated. The rear panel remote Line/Memory Select contact closure inputs perform the same function as the pushbuttons.

Memory Recall Mode: Selects which stored memory preset (1-6) will be loaded into the AV62. The LED adjacent to the button will illuminate to indicate the currently active memory. The AV62 is in Memory Recall Mode when the Local Mode LED (just to the left of the Power LED) is not illuminated. Note that the front panel buttons are the only live front panel controls when the AV62 is in the Memory Recall Mode. The rear panel remote Line/Memory Select contact closure inputs perform the same function as the pushbuttons.

Special Line Input Select Functions - The Line Input select buttons listed below have special functions when pushed while the power is applied. The correct procedure for using the special functions is to turn power to the AV62 Off, push the desired button, and reapply power.

Single Line Input Select Mode, Line Input 1 Select Button: This button forces the AV62 into the single line input select mode. In this mode, only one line input at a time may be selected as the active input. When a new input is selected (using the Line Input Select buttons or the rear panel remote Line/Memory Select contact closure inputs), the previous input is automatically turned off.

Multiple Line Input Select Mode, Line Input 2 Select Button: This button forces the AV62 into the multiple line input select mode. In this mode, any number of line inputs may be selected as active inputs. An input will be turned on by the first press of its associated button, and the next press of that button will turn the input off.

Local Mode/Memory Recall Mode, Line Input 3 Select Button: This button toggles the AV62 between the Local Mode and the Memory Recall Mode. In the Memory Recall Mode, the AV62 will automatically load stored memory 1 as the current active memory at power up. Note that in the Memory Recall Mode, the Line Input Select buttons or the rear panel remote Line/Memory Select contact closure inputs select which of the stored memories(1-6) will be loaded as the active memory.

Reset to Factory Defaults, Line Input 6 Select Button: This button resets the AV62 non-volatile memory to the factory default state. The one exception is that the LecNet address is not reset to the factory default.

tone CONTROLS - Adjusts the bass and treble response of the summed program inputs. The range is +/-10dB, with 2.5dB steps for both bass and treble. Note that the Program Tone controls do not affect signals linked from the microphone inputs. See also the Link Button description below.

BALANCE - Adjusts the left/right stereo balance of the program output.

LIMIT LED - Illuminates when the program output limiter is active.

PROGRAM OUTPUT - Adjusts the audio level of the Program output.

MONO AUDIO SECTION

MIC IN 1-2 LEVEL - Controls the level of each of the microphone inputs.

STONE CONTROLS - Adjusts the bass and treble response of the summed microphone inputs. The range is +/-10dB, with 2.5dB steps for both bass and treble. Note that the Mono Tone controls do not affect signals linked from the program inputs. See also the Link Button description below.

LIMIT LED - Illuminates when the program output limiter is active.

MONO OUTPUT - Adjusts the audio level of the Program output.

LOCAL LED - Lights when the AV62 is in the Local Mode. Local mode means that the AV62 is controlled by the front and rear panel controls. The Local LED is extinguished when the AV62 is in the Memory Recall Mode.

COMBINE BUTTON/COMBINE LED - The Link Button interconnects the Program and Mono outputs in the following way. Stereo program signals are summed to mono and mixed with the microphone signals. All of these signals then come out of the Mono Output. Note that the Mono Tone controls still only affect the summed microphone audio, but the Mono Output control effects all the signals. Similarly, the summed microphone signals are mixed at equal levels with both the left and right program signals. All of these signals then come out of the Program Output. Note that the Program Tone controls still only affect the summed program audio, but the Program Output control affects all the signals.

REAR PANEL DESCRIPTION

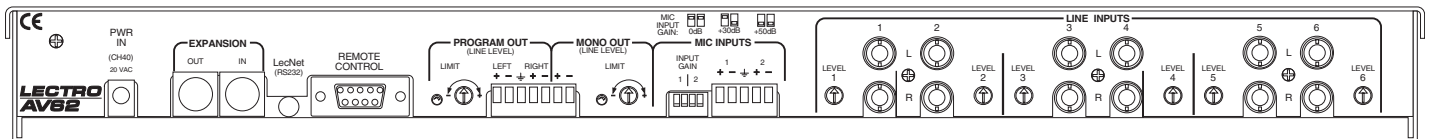

Figure 7 - AV62 Rear Panel

PWR IN - Accepts power from a CH40 (single AC adaptor) or a CH4-40 (quad AC adaptor).

EXPANSION IN/OUT - Allows the interconnection of the AV62 to other LecNet equipment.

LecNet (RS-232) - Allows a PC or an RS-232 compatible controller (eg. AMX or Crestron) to communicate with the AV62.

REMOTE CONTROL - Allows remote selection of line level inputs (when the AV62 is in the Local mode) or remote selection of memory presets (when the AV62 is in the Memory mode). Also allows for remote control of the Program and Mono output levels.

Remote Control Connector Pinout

Pin Number	Function
	Local Mode
1	Line Input 1
2	Line Input 2
3	Line Input 3
4	Line Input 4
5	Line Input 5
6	Line Input 6
7	Program Volume Control
8	Mono Volume Control
9	Ground
	Memory Recall Mode
1	Memory 1
2	Memory 2
3	Memory 3
4	Memory 4
5	Memory 5
6	Memory 6
7	Program Volume Control
8	Mono Volume Control
9	Ground

PROGRAM (MONO) OUTPUT LIMITER - Adjusts the level of the Program (Mono) output limiter circuit. Fully counterclockwise (-) sets the level at which limiting starts to -15dBu. Fully clockwise (+) is equivalent to limiter "out". Note that the limiter acts on the program (mono) signal before the output level control.

PROGRAM OUTPUT LEFT/RIGHT - Supplies a balanced output signal for both the left and right program channels. If an unbalanced signal is desired, simply use the (+) output and the ground terminal. The (-) terminal should be left unconnected.

MONO OUTPUT - Supplies a balanced mono output signal. If an unbalanced signal is desired, simply use the (+) output and the ground terminal. The (-) terminal should be left unconnected.

MIC INPUTS 1-2 - Accepts balanced or unbalanced signal. Fully balanced differential input, RF filtered.

MIC INPUT GAIN SWITCHES 1-2 - Allow mic input gain to be set. Each pair of dip switches set the gain of the input preamplifier. 0dB gain, for line level sources, is set when both switches are in the up position. 30dB gain, typically for high output (electret) microphones, is set when the leftmost switch of the pair is in the up position and rightmost switch is in the down position. 50dB gain, used for low output (dynamic) microphones, is set when both switches are in the down position.

LINE INPUTS 1-6 - Accepts unbalanced stereo consumer level (-10dBu nominal) signals from CD players, VCRs, multimedia sound cards, etc.

INPUT LEVEL CONTROLS - Sets the input gain of the associated program input. Controls both left and right channels simultaneously.

OPERATING INSTRUCTIONS

Setup of the AV62 consists of choosing rear panel microphone dip switch options, setting rear panel line levels, and adjusting front panel tone and volume controls. Using the Remote Level Control capability of the AV62 is addressed in the next section.

- 1) There are several options which may be set on the AV62 by pressing one of the Program Input Select buttons while turning on the power to the AV62. These button and their associated functions are listed below:

Program Input Select 1: Sets the AV62 into the **single program input mode**. This means that the AV62, when in Local mode (i.e. the Local Mode LED is lighted), may have only one program input active at a time. The single input mode forces the AV62 to operate as a one-of-six signal switcher as far as program inputs are concerned. For example, if program input 1 was active and the Program Input Select 3 button is pushed, program input 1 will be muted and program input 3 will become active.

Program Input Select 2: Sets the AV62 into the **multiple program input mode**. This means that the AV62, when in Local mode (i.e. the Local Mode LED is lighted), may have any combination of its six inputs active. The multiple input mode forces the AV62 to operate as a six channel mixer as far as program inputs are concerned. For example, if program input 1 was active and the Program Input Select 3 button is pushed, both program input 1 and program input 3 will be active.

Program Input Select 3: Toggles the AV62 between Local Mode and Memory Recall Mode. In Local Mode the Local Mode LED is lighted, and the Program Input Select buttons or the rear panel remote Line/Memory Select contact closure inputs determine which program inputs are active (see single and multiple input mode descriptions above). In the Memory Recall Mode the Local Mode LED is not lighted, and the Program Input Select buttons or the rear panel remote Line/Memory Select contact closure inputs determine which stored memory (1-6) will be the active memory.

Program Input Select 6: Resets the AV62 non-volatile memory to the factory default settings. The only exception to this is that the LecNet address is not affected by the reset.

- 2) Set up the preamplifier gain using the dip switch positions shown on the rear panel. The 0dB position is used for line level sources like tape players or VCRs. The 30dB position works well for higher output microphones like electrets. The 50dB position is best for dynamic microphones, or electret types where the distance from the talker to the microphone is more than 3 feet or so. Start with the front panel Mic In level at 12 o'clock (straight up). Adjust the front panel Mono Mic Out level control until the desired sound reinforcement level is reached. Mono Bass and Treble controls may now be adjusted for best sound.
- 3) Set the rear panel Program level controls to the 12 o'clock (straight up) position. Further adjustment of these controls may be necessary if there is wide variation in level between program sources. Select one of the active program sources using the front panel Program Input Select pushbuttons. Adjust the front panel Stereo Program Out level control (and Balance control, if needed) until the desired program level is reached. Mono Bass and Treble controls may now be adjusted for best sound.
- 4) The Left and Right Program outputs and the Mono output have a limiter function which can be applied to limit the maximum output level of these signals. If limiting is desired, adjust the rear panel Program or Mono limiter control (starting from fully clockwise) counterclockwise until the appropriate limit LED flashes. This indicates that the output is in limiting.

The system is now ready for use.

REMOTE LEVEL CONNECTIONS

The figure below shows several options which may be used for remote level control of the AV62. Pots, switches, and external control voltages may all be used as the application dictates.

WIRING DIAGRAMS, AV62 REMOTE CONTROL PORT

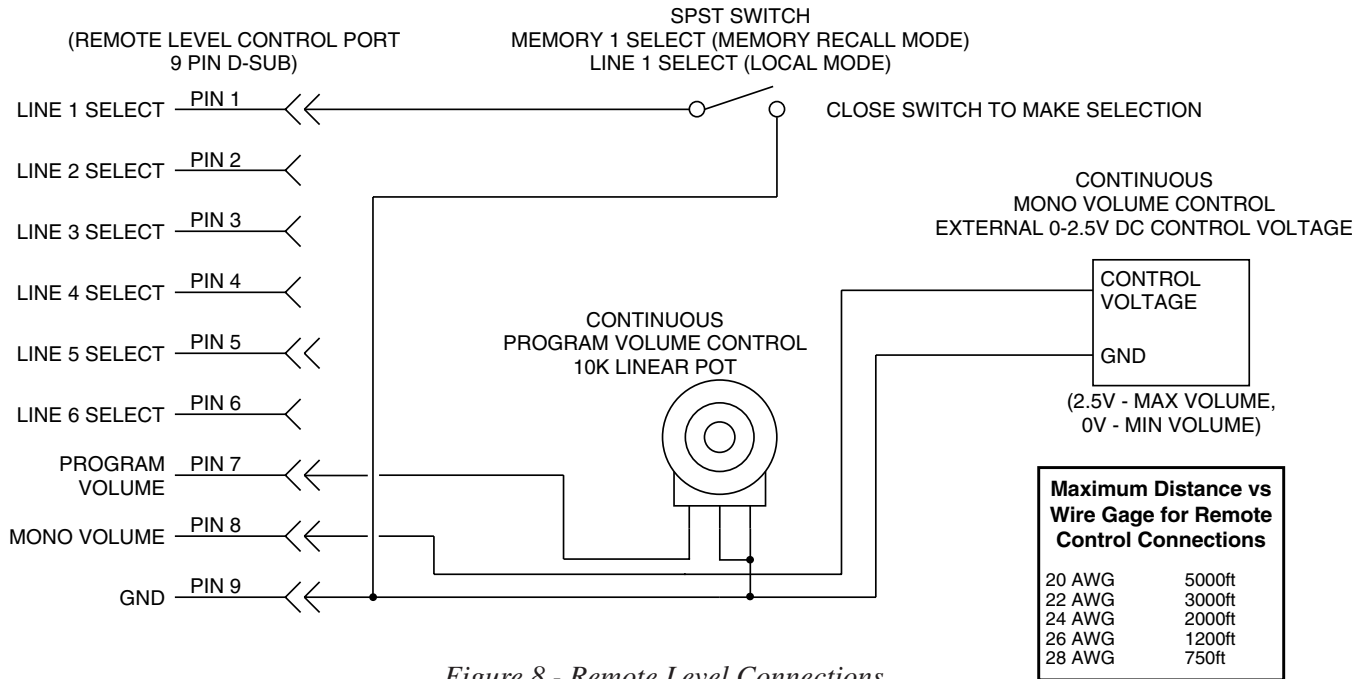

Figure 8 - Remote Level Connections

TROUBLESHOOTING

SYMPTOM

1) No sound from system

POSSIBLE CAUSE

- 1) Mono or Program level control not turned up
- 2) Mic level not turned up
- 3) Program input gain setting too low
- 4) Program input not selected as an active input
- 5) Remote level control turned down

SERVICE AND REPAIR

If your system malfunctions, you should attempt to correct or isolate the trouble before concluding that the equipment needs repair. Make sure you have followed the setup procedure and operating instructions. Check out the inter-connecting cords and then go through the TROUBLE SHOOTING section in the manual

We strongly recommend that you **do not** try to repair the equipment yourself and **do not** have the local repair shop attempt anything other than the simplest repair. If the repair is more complicated than a broken wire or loose connection, send the unit to the factory for repair and service. Don't attempt to adjust any controls inside the units. Once set at the factory, the various controls and trimmers do not drift with age or vibration and never require readjustment. **There are no adjustments inside that will make a malfunctioning unit start working.**

LECTROSONICS service department is equipped and staffed to quickly repair your equipment. In-warranty repairs are made at no charge in accordance with the terms of the warranty. Out of warranty repairs are charged at a modest flat rate plus parts and shipping. Since it takes almost as much time and effort to determine what is wrong as it does to make the repair, there is a charge for an exact quotation. We will be happy to quote approximate charges by phone for out of warranty repairs.

RETURNING UNITS FOR REPAIR

You will save yourself time and trouble if you will follow the steps below:

- A. DO NOT return equipment to the factory for repair without first contacting us by letter or by phone. We need to know the nature of the problem, the model number and the serial number of the equipment. We also need a phone number where you can be reached 8 am to 4 pm (Mountain Standard Time).
- B. After receiving your request, we will issue you a return authorization number (R.A.). This number will help speed your repair through our receiving and repair departments. The return authorization number must be clearly shown on the outside of the shipping container.
- C. Pack the equipment carefully and ship to us, shipping costs prepaid. If necessary, we can provide you with the proper packing materials. UPS is usually the best way to ship the units. Heavy units should be "double-boxed" for safe transport.
- D. We also strongly recommend that you insure the equipment, since we cannot be responsible for loss of or damage to equipment that you ship. Of course, we insure the equipment when we ship it back to you.

Mailing address:

Lectrosonics, Inc.
PO Box 15900
Rio Rancho, NM 87174

Shipping address:

Lectrosonics, Inc.
581 Laser Rd.
Rio Rancho, NM 87124
USA

Telephones:

(505) 892-4501
(800) 821-1121
FAX: (505) 892-6243
USA

Web: <http://www.lectrosonics.com>

email: sales@lectrosonics.com

SPECIFICATIONS

Program Input	
Type:	Unbalanced RCA
Impedance:	10K ohms
Input Gain Range:	+15dB to Off
Maximum Input Level:	+4dBu at maximum gain
Mic/Line Input	
Type:	Electronically balanced and RF filtered
Impedance:	Greater than 2K, any gain setting
Input Gain Settings:	0dB, +30dB, +50dB
EIN, 20-20KHz:	-126dBu (+50dB gain)
Maximum Input Level:	+15dBu at 0dB gain -15dBu at +30dB gain -35dBu at +50dB gain
Mono/Program Out	
Impedance:	200 Ohms balanced; 100 Ohms unbalanced
Max output level:	+26dBu, \geq 10k load balanced, +20dBu unbalanced
Remote Level Control Range:	0dB to off for a resistance of 10K ohms to 0 ohms
Serial Communication (RS-232):	9600 baud, 8 data bits, no parity, 1 stop bit
Mono/Program Out Limiters	
Threshold:	-15dBu to +25dBu(off)
Maximum System Gain	
Mic Input to Mono Out:	72dB
Program Input to Program Output:	22dB
System Noise:	Less than -80dBu (20Hz-20kHz)
System Frequency Response:	15Hz - 55kHz , +0/-3dB
System THD:	Less than 0.1%, any gain setting (+10dBu out)
System IMD:	Less than 0.1%, any gain setting (+10dBu out)
Phantom Power:	+15V, switch selectable per channel
Power Consumption:	10 Watts max at 20VAC
Weight:	3 lbs, 4 ozs
Dimensions:	19"wide x 1.75"high x 8"deep

Specifications subject to change without notice.

This product meets the CE Compliance Standards - EN55022 and EN50082-1:1998. A copy of the Declaration of Conformity may be requested from your dealer or by contacting the factory directly:

Lectrosonics, Inc.

Marketing Department

581 Laser Rd. NE, Rio Rancho, NM 87124 USA

tel: 505-892-4501 fax: 505-892-6243 e-mail: marketing@lectrosonics.com

SERIAL CABLE WIRING DIAGRAMS

The serial port on the LecNet device is a minimal RS-232 implementation. The figure shows the wiring diagram to accommodate interconnection with either a 9 or a 25 pin serial port on a PC or other serial device.

LecNet to PC Connections

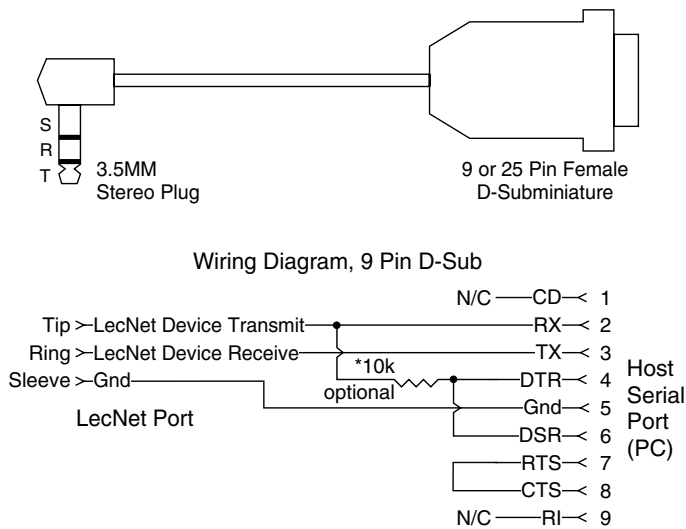

LecNet to AMX Connection

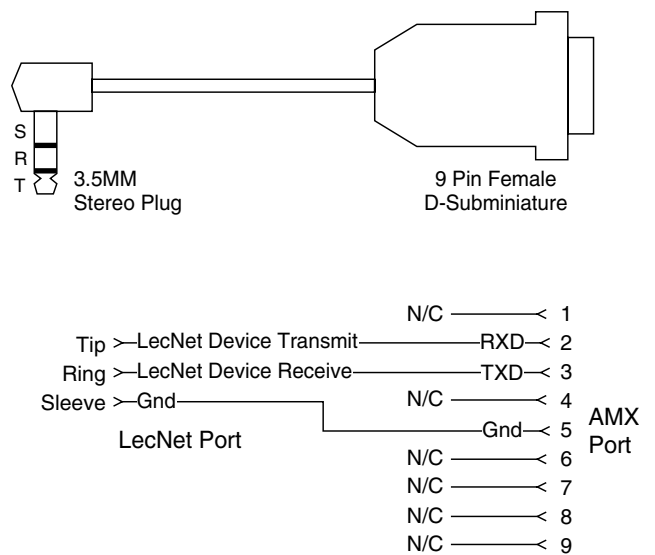

AMX Programming Notes

If you are using an AMX system to control your LecNet equipment, you'll want to purchase the Lectrosonics PT3 Protocol Translator. The PT3 connects between the AMX bus and any LecNet equipment. With the PT3, the LecNet equipment looks just like native AMX equipment. The PT3 is the fastest and most productive way to control LecNet devices with an AMX system.

SERIAL PORT COMMANDS AVAILABLE

The AV62 uses a modification of the typical one-to-one connection between two RS-232 compatible devices. The AV62 has both an RS-232 transmitter and receiver section. The transmitter section is “tri-stated”, or placed in a high impedance mode, until the particular device is addressed. To facilitate the simple parallel connection of multiple devices on a single RS-232 port, an addressing scheme is employed to route commands from the host to the proper device. When a device receives its address from the host computer, it temporarily turns on its RS-232 transmitter long enough to send whatever data is requested by the host. In this way, multiple devices may drive a single transmit signal back to the host, because only the addressed device will turn on its transmitter.

Valid address values are 128-254 (80h-FEh). 255 (FFh) is an invalid address and must not be used. Because the AV62 will interpret any single data byte whose value is greater than 127 as an address, single byte data (as opposed to addresses) sent from the host must be in the range of 0-127. If a data value needs to be output that exceeds 127, two bytes are output such that the first byte is the lower 7 bits of the 8 bit value, and the second byte is 1 if the MSB of the data byte is 1, or 0 if the MSB of the data byte is 0.

Each AV62 command must be preceded by the address of the device to be controlled. If a device with the requested address exists on the system, it will respond by sending a “0” back to the host. The following code fragment, in BASIC, would be used to get an “Acknowledge” name string back from an AV62:

```
OPEN "COM1:9600,N,8,1" FOR RANDOM AS #1 LEN = 256 'Open com port 1 for 9600 'baud, no
                                                'parity, 8 data 'bits, 1 stop bit.
...
...
PRINT #1, CHR$(138);                          'Output the device address.
DataByte% = ASC(INPUT$(1, #1))                  'Receive "0" byte. The ASC function is used to convert the
                                                'received string data to numeric data.

PRINT #1, CHR$(1);                              'Output the "Acknowledge" command.
DataByte% = ASC(INPUT$(1,#1))                    'Receive the length of the acknowledge string (4 for the AV62).
Name$ = INPUT$(DataByte%,#1)                     'Receive the name string ("AV62")
```

The first PRINT and INPUT\$ sequence must precede every command sent, even if the command is sent to the same AV62 as the previous command. Thus, each interchange with an AV62 follows this pattern:

- 1) Host sends device address (1 byte);
- 2) Host receives byte of “0” from AV62 as acknowledgement;
- 3) Host sends command (1 byte) to AV62;
- 4) Host and AV62 exchange data based on particular command sent.

Note that you must wait for the “0” acknowledgement byte from the AV62 before sending a command to the AV62.

AV62 Remote Control Usage Tips

- 1) Review the general LecNet command structure sequence above, and be sure you understand it well. Incorrect byte order, or failure to provide all necessary LecNet information will cause the AV62 to reset itself rather than be stuck forever waiting for information from the host.
- 2) Before attempting to control the AV62 remotely, use the Set Current Memory command (11) to set the AV62 to one of the stored memories (i.e. memories 1-6). The reason for this is that if the AV62 is in the Local mode (memory 0), the AV62 will read front and rear panel controls to set its operational parameters. By setting the AV62 to one of the stored memories, the AV62 will ignore the front and rear panel controls and you may adjust the operational parameters using serial commands. The Set Current Memory command allows the option to store the memory selection in non-volatile memory or not. If you simply want to control the AV62 remotely, but do not want to change the current power-up memory, don't store the new selection in non-volatile memory.

The following is a listing of available commands grouped based on the AV62 function to which the commands are related.

The word "Host" in the command descriptions means the IBM PC, PC compatible, or AMX or Crestron controller to which the AV62 is connected. Note that all numerical commands and data are decimal numbers, not ASCII characters!

General Device Commands

Acknowledge - Causes the AV62 to send its "name" string back. The first data byte is the length of the name string, and the rest of the data bytes are the device name.

Host sends command - 1

Host receives data bytes: Byte 1 is the length of the name string (4 for the AV62), bytes 2, 3, 4, and 5 are the ASCII values for "AV62" (65,86,54,50).

Change Device Address - Changes the AV62 device address and stores the new address in EEPROM.

Host sends command - 2

Host sends 1 byte: device address, valid range 128 to 254.

Output Firmware Version - Causes the AV62 to outputs the version number of the current firmware. For example, Version 1.0 software would be returned as 10 (decimal).

Host sends command - 25

Host receives data byte: firmware version.

Get Current Audio Levels - Outputs the program left and right audio level, as well as the mono audio level. Audio level data ranges from 0 to 255. 0 corresponds to -65dBu, and 255 corresponds to +20dBu. Scaling is .333dB/bit. Either the current audio levels may be output, or the peak audio levels since the last check. The latter option is useful if the levels are not checked often.

Host sends command - 4

Host sends 1 data byte: 0 - get current audio levels, 1 - get peak audio levels since last check.

Host receives 3 data bytes: Byte 1: Left audio level
Byte 2: Right audio level
Byte 3: Mono audio level

Get Current Memory - Outputs the current active memory. Data ranges from 0-6, where 0 means the AV62 is in the Local mode, and 1-6 means that the AV62 is set to the operational parameters of one of the stored memories.

Host sends command - 10

Host receives 1 data byte: current memory, 0-6

Set Current Memory - Allows the AV62 to be set to either Local mode (memory 0) or to one of the stored memories (memories 1-6). Also allows the option of storing the memory selection in non-volatile memory such that it becomes the power-up default memory setting. Note that to remotely control the operation of the AV62, it must be set to one of the stored memories, 1-6.

Host sends command - 11

Host sends 2 data bytes: Byte 1: New memory selection, 0-6
Byte 2: 0 - don't save to non-volatile memory (use this option if you don't want to change the power-up memory default) 1 - save to non-volatile memory

Host receives 1 data byte: 100, to signify the completion of storage in non-volatile memory. This byte is sent regardless of which option is selected in Byte 2.

Get Stored Memory Contents - Outputs the contents of one of the six stored memories (1-6).

Host sends command - 12

Host sends 1 data byte - desired memory

Host receives 19 bytes:

- Bytes 1-6: Program input gain for inputs 1-6. Data ranges from 0-31, with 0 corresponding to maximum gain, 30 to minimum gain, and 31 to input off.
- Bytes 7-8: Mic input gain for mics 1 and 2. Data ranges from 0-63, with 0 corresponding to maximum gain, 62 to minimum gain, and 63 to mic input off.
- Byte 9: Program bass level. Data ranges from 0 to 8, where 0 corresponds to 10dB boost, 4 is flat, and 8 is 10dB cut. Each step is 2.5dB.
- Byte 10: Program treble level. Data ranges from 0 to 8, where 0 corresponds to 10dB boost, 4 is flat, and 8 is 10dB cut. Each step is 2.5dB.
- Byte 11: Mic bass level. Data ranges from 0 to 8, where 0 corresponds to 10dB boost, 4 is flat, and 8 is 10dB cut. Each step is 2.5dB.
- Byte 12: Mic treble level. Data ranges from 0 to 8, where 0 corresponds to 10dB boost, 4 is flat, and 8 is 10dB cut. Each step is 2.5dB.
- Byte 13: Program output gain. Data ranges from 0 to 255, where 0 corresponds to maximum gain and 255 corresponds to minimum gain. Gain scaling is 0.333dB/bit.
- Byte 14: Program output balance. Data ranges from 0 to 31, where 0 corresponds to full right, 14 and 15 are equal left and right, and 31 is full left.
- Byte 15: Mono output gain. Data ranges from 0 to 255, where 0 corresponds to maximum gain and 255 corresponds to minimum gain. Gain scaling is 0.333dB/bit.
- Byte 16: Left program output mix. Bits 0, 1, and 3 are the only meaningful bits. If bit 0 is 1, the Left program output mix includes the summed signals from the left program inputs. If bit 1 is 1 the Left program output mix includes the summed signals from the microphone inputs. If bit 3 is 1 the Left program output mix includes the signal from the Expansion input.
- Byte 17: Right program output mix. Bits 0, 1, and 3 are the only meaningful bits. If bit 0 is 1, the Right program output mix includes the summed signals from the right program inputs. If bit 1 is 1 the Right program output mix includes the summed signals from the microphone inputs. If bit 3 is 1 the Right program output mix includes the signal from the Expansion input.
- Byte 18: Mono program output mix. Bits 0, 1, 3, and 5 are the only meaningful bits. If bit 0 is 1, the Mono program output mix includes the summed signals from the microphone inputs. If bit 1 is 1 the Mono program output mix includes the summed signals from the left program inputs. If bit 3 is 1 the Mono program output mix includes the summed signals from the right program inputs. If bit 5 is 1 the Mono program output mix includes the signal from the Expansion input.
- Byte 19: Expansion out mix. Bits 0 and 1 are the only meaningful bits. If bit 0 is 1, the Expansion out mix includes the summed signals from the microphone inputs. If bit 1 is 1 the Expansion out mix includes the summed signals from the left and right program inputs.

Program/Mic Input Commands

Get Local Mode Line Input Mixer Status - Outputs the mixer mode status associated with Local mode operation. Single mode makes the AV62 operate like a signal switcher for program inputs. Multiple mode makes the AV62 operate like a true audio mixer, where any number of inputs may contribute to the program output mix.

Host sends command - 20

Host receives 1 data byte: Mixer mode. 0 - Single mode (i.e. only one program input may be active at a time), 1 - Multiple mode (i.e. any number of inputs may be simultaneously active).

Set Local Mode Line Input Mixer Status - Allows the Local mixer mode of the AV62 to be set. The new value is stored in non-volatile memory.

Host sends command - 21

Host sends 1 data byte: Mixer mode: 0 - Single, 1 - Multiple

Host receives 1 data byte: 100, to signify the completion of storage in non-volatile memory.

Get Current Line Input Levels - Outputs the setting of the gain of the specified line level input. Input number data ranges

from 0-5, corresponding to inputs 1-6. Gain data ranges from 0 to 31, with 0 corresponding to maximum gain, 30 to minimum gain, and 31 to input off.

Host sends command - 22

Host sends 1 data bytes: Input to get, 0-5 corresponds to inputs 1-6

Host receives 1 data byte: Gain value, 0-31 (see above for gain data range interpretation)

Set Current Line Input Levels - Allows the setting of the gain of the six line level inputs. Input number data ranges from 0-5, corresponding to inputs 1-6. Gain data ranges from 0 to 31, with 0 corresponding to maximum gain, 30 to minimum gain, and 31 to input off.

Host sends command - 23

Host sends 2 data bytes: Byte 1: Input to set, 0-5 corresponds to inputs 1-6
Byte 2: New gain level, 0-31 (see above for gain data range)

Get Current Mic Input Levels - Outputs the setting of the gain of the specified mic level input. Input number data is 1 or 2, corresponding to mic 1 or mic 2. Gain data ranges from 0 to 63, with 0 corresponding to maximum gain, 62 to minimum gain, and 63 to input off.

Host sends command - 24

Host sends 1 data bytes: Input to get, 0 or 1 corresponds to mic1 or mic 2

Host receives 1 data byte: Gain value, 0-63 (see above for gain data range interpretation)

Set Current Mic Input Levels - Allows the setting of the gain of the two mic level inputs. Input number data is 1 or 2, corresponding to mic 1 or mic 2. Gain data ranges from 0 to 63, with 0 corresponding to maximum gain, 62 to minimum gain, and 63 to input off.

Host sends command - 26

Host sends 2 data bytes: Byte 1: input to set, 0 or 1, corresponds to mic 1 or mic 2
Byte 2: new gain level, 0-63 (see above for gain data range)

Get Current Tone Control Levels - Outputs the current setting of any one of the four tone controls. Tone control data range is 0-8, where 0 corresponds to 10dB boost, 4 is flat, and 8 is 10dB cut.

Host sends command - 27

Host sends 1 data byte: Desired tone control, 0 - Mic bass, 1 - Line bass, 2 - Mic treble, 3 - Line treble.

Host receives 1 data byte: Tone control level, 0-8

Set Current Tone Control Levels - Allows changing of the current setting of any one of the four tone controls. Tone control data range is 0-8, where 0 corresponds to 10dB boost, 4 is flat, and 8 is 10dB cut.

Host sends command - 28

Host sends 2 data bytes: Byte 1: Desired tone control, 0 - Mic bass, 1 - Line bass, 2 - Mic treble, 3 - Line treble.
Byte 2: New tone control level, 0-8

Program/Mono Output Commands

Get Current Program Gain Level - Outputs the current setting of the program output gain. Gain data ranges from 0 to 255. 0 corresponds to maximum gain, and 255 to minimum gain. Gain scaling is .333dB/bit.

Host sends command - 32

Host receives 1 data byte: Program output gain level, 0-255

Set Current Program Gain Level - Allows changing of the current setting of the program output gain. Gain data ranges from 0 to 255. 0 corresponds to maximum gain, and 255 to minimum gain. Gain scaling is .333dB/bit.

Host sends command - 33

Host sends 2 data bytes: Byte 1: Program output gain, least significant 7 bits
Byte 2: Program output gain, most significant bit

Get Current Program Balance Level - Outputs the current setting of the program balance. Balance data ranges from 0 to 31. 0

corresponds to full right, 14 and 15 are equal left and right, and 31 is full left. Gain scaling is .333dB/bit.

Host sends command - 34

Host receives 1 data byte: Program balance level, 0-31

Set Current Program Balance Level - Allows changing of the current setting of the program balance. Balance data ranges from 0 to 31. 0 corresponds to full right, 14 and 15 are equal left and right, and 31 is full left. Gain scaling is .333dB/bit.

Host sends command - 35

Host sends 1 data byte: Program balance level, 0-31

Get Current Mono Gain Level - Outputs the current setting of the mono output gain. Gain data ranges from 0 to 255. 0 corresponds to maximum gain, and 255 to minimum gain. Gain scaling is .333dB/bit.

Host sends command - 36

Host receives 1 data byte: Mono output gain level, 0-255

Set Current Mono Gain Level - Allows changing of the current setting of the Mono output gain. Gain data ranges from 0 to 255. 0 corresponds to maximum gain, and 255 to minimum gain. Gain scaling is .333dB/bit.

Host sends command - 37

Host sends 2 data bytes: Byte 1: Mono output gain, least significant 7 bits
Byte 2: Mono output gain, most significant bit

Get Output Mix Status - Outputs the mix status of any one of the four AV62 outputs. Mix status indicates which available signals in the AV62 are current components of the desired output.

Host sends command - 50

Host sends 1 data byte - Desired output, 0 - Left, 1 - Right, 2 - Mono, 3 - Expansion Out

Host receives 1 data byte: Mix status (see the following table)

Output	Component Signals of the Mix					
	Bit 5	Bit 4	Bit 3	Bit 2	Bit 1	Bit 0
Left:	N/A	N/A	Exp In	Mono	N/A	Left
Right:	N/A	N/A	Exp In	Mono	N/A	Right
Mono:	Exp In	N/A	Right	N/A	Left	Mono
Exp Out:	N/A	N/A	N/A	N/A	L+R	Mono

Left is the summed signal from the left program inputs.

Right is the summed signal from the right program inputs.

Mono is the summed signal from the mic inputs.

Exp In is the signal from the Expansion In port on the rear of the AV62. This signal can be originated from AM8s, TH2s, or TA1s connected to the Expansion In port of the AV62.

Exp Out is the signal propagated to devices connected to the Expansion In port of the AV62.

Set Output Mix Status - Allows changing the mix status of any one of the four AV62 outputs. See the description of Get Output

Mix Status above.

Host sends command - 51

Host sends 2 data bytes: Byte 1: Desired output, 0 - Left, 1 - Right, 2 - Mono, 3 - Expansion Out

Byte 2: Mix status (see the following table)

Output	Component Signals of the Mix					
	Bit 5	Bit 4	Bit 3	Bit 2	Bit 1	Bit 0
Left:	N/A	N/A	Exp In	Mono	N/A	Left
Right:	N/A	N/A	Exp In	Mono	N/A	Right
Mono:	Exp In	N/A	Right	N/A	Left	Mono
Exp Out:	N/A	N/A	N/A	N/A	L+R	Mono

Left is the summed signal from the left program inputs.

Right is the summed signal from the right program inputs.

Mono is the summed signal from the mic inputs.

Exp In is the signal from the Expansion In port on the rear of the AV62. This signal can be originated from AM8s, TH2s, or TA1s connected to the Expansion In port of the AV62.

Exp Out is the signal propagated to devices connected to the Expansion In port of the AV62.

FCC PART 15 NOTICE

This equipment has been tested and found to comply with the limits for a class B digital device, pursuant to Part 15 of the FCC Rules. These limits are designed to provide reasonable protection against harmful interference in a residential installation. This equipment generates, uses and can radiate radio frequency energy and, if not installed and used in accordance with the instructions, may cause harmful interference to radio communications. If this equipment does cause harmful interference to radio or television reception, which can be determined by turning the equipment off and on, the user is encouraged to try to correct the interference by one or more of the following measures:

- Reorient or relocate the receiving antenna.
- Increase the separation between the equipment and receiver.
- Connect the equipment into an outlet on a circuit different from that to which the receiver is connected.
- Consult the dealer or an experienced radio/TV technician for help.

Intentionally Blank

LIMITED ONE YEAR WARRANTY

The equipment is warranted for one year from date of purchase against defects in materials or workmanship provided it was purchased from an authorized dealer. This warranty does not cover equipment which has been abused or damaged by careless handling or shipping. This warranty does not apply to used or demonstrator equipment.

Should any defect develop, Lectrosonics, Inc. will, at our option, repair or replace any defective parts without charge for either parts or labor. If Lectrosonics, Inc. cannot correct the defect in your equipment, it will be replaced at no charge with a similar new item. Lectrosonics, Inc. will pay for the cost of returning your equipment to you.

This warranty applies only to items returned to Lectrosonics, Inc. or an authorized dealer, shipping costs prepaid, within one year from the date of purchase.

This Limited Warranty is governed by the laws of the State of New Mexico. It states the entire liability of Lectrosonics Inc. and the entire remedy of the purchaser for any breach of warranty as outlined above. NEITHER LECTROSONICS, INC. NOR ANYONE INVOLVED IN THE PRODUCTION OR DELIVERY OF THE EQUIPMENT SHALL BE LIABLE FOR ANY INDIRECT, SPECIAL, PUNITIVE, CONSEQUENTIAL, OR INCIDENTAL DAMAGES ARISING OUT OF THE USE OR INABILITY TO USE THIS EQUIPMENT EVEN IF LECTROSONICS, INC. HAS BEEN ADVISED OF THE POSSIBILITY OF SUCH DAMAGES. IN NO EVENT SHALL THE LIABILITY OF LECTROSONICS, INC. EXCEED THE PURCHASE PRICE OF ANY DEFECTIVE EQUIPMENT.

This warranty gives you specific legal rights. You may have additional legal rights which vary from state to state.

LECTROSONICS, INC.

581 LASER ROAD
RIO RANCHO, NM 87124 USA

November 1, 2001