

CR187

Compact Receiver



Fill in for your records:

Serial Number:

Purchase Date:

Table of Contents

| | |
|--|-----------|
| Introduction | 4 |
| General Technical Description | 4 |
| CR187 Block Diagram..... | 4 |
| Controls and Functions | 5 |
| Receiver Front Panel | 5 |
| Modulation LEDs..... | 5 |
| Output Control..... | 5 |
| EXT/OFF/INT Switch | 5 |
| Power LED | 5 |
| RF LED | 5 |
| Receiver Rear Panel | 6 |
| 12 VDC Input..... | 6 |
| Audio Output XLR Jack..... | 6 |
| Mini Phone Jack..... | 6 |
| Antenna Terminal | 6 |
| Battery Replacement | 7 |
| Antenna Use and Placement | 8 |
| Operating Instructions | 9 |
| Troubleshooting | 9 |
| Replacement Parts and Accessories | 10 |
| Specifications and Features | 10 |
| Service and Repair | 11 |
| Returning Units for Repair | 11 |

Introduction

The CR187 receiver design originated in the late 1980's with a feature set intended for camera mounted ENG applications. It's fixed frequency design included extremely sharp front-end filters and narrowband crystal filters in the IF stage, which likely explains its continued use in today's crowded RF environment.

The receiver operates on a single 9V battery or external DC power, allowing it to be used in a wide variety of applications in broadcast and film production, ENG and with almost any pro sound equipment.

General Technical Description

The block diagram of the receiver provides a basic overview of the major circuit sections.

The RF front-end amplifier consists of three cascaded pairs of helical resonators for high selectivity. Between the three resonators are two low noise grounded gate JFET amplifiers. These amplifiers are designed to provide only enough gain to make up for the loss through the helical resonators. This combination of low front-end gain, coupled with the extremely high selectivity of the cascaded helical resonators results in no overloading, even on extremely strong signals. Rejection of out of band signals is maximized, and intermodulation products are suppressed.

The mixer stage consists of a high level double balanced diode mixer. The oscillator is biased from a regulated supply, yielding stable performance over the entire life of the battery. The local oscillator crystal operates at approximately 16 MHz, and can be adjusted above and below the nominal frequency in order to place the 21.4 MHz IF in the center of the crystal filter's narrow pass band. The high selectivity of the crystal filter stage further minimizes the possibility of interference from signals on adjacent frequencies.

One monolithic integrated circuit filters the second IF, demodulates the audio, provides squelch control and drives the RF output LED. The second IF filter is centered on 1 MHz and drives a double tuned quadrature type FM demodulator. The squelch circuit is a supersonic noise detector type and is factory set for a -20 dB SINAD level (about .5 uV). The squelch level is regulated and temperature compensated to maintain a consistent squelch level under all conditions.

The overall wireless system utilizes "compandor" noise reduction, which consists of a compressor in the transmitter and expander in the receiver. The receiver decodes (expands) the compressed signal coming from the transmitter in a 2:1. The process senses the signal level, and dynamically increases the gain for loud signals or decreases the gain for soft signals. In this way, the original dynamic range of the transmitted signal is restored and the signal-to-noise ratio is increased significantly. De-emphasis (HF roll-off) is also applied to reverse the pre-emphasis (HF boost) applied in the transmitter as an additional noise reduction technique.

The expander circuit is driven by a multiple pole active low-pass filter. The filter ensures that supersonic noise will not cause the expander to increase gain incorrectly. This filter also drives the -20 dB modulation LED.

The output of the receiver is a balanced microphone level signal delivered on an XLR connector. The output level control is actually a balanced attenuator to adjust the signal from -20 dBV in the fully clockwise position to -50dBV in the fully counter-clockwise position. This preserves the signal to noise ratio regardless of what output level is set.

A separate output is provided to drive headphones separately from the main XLR output. The level is affected by both the main output control and a secondary trimpot on the side panel.

Warning: The CR187 is a negative ground device. Do not connect this receiver to a positive ground device through the audio cabling. Damage to either device could result.

CR187 Block Diagram

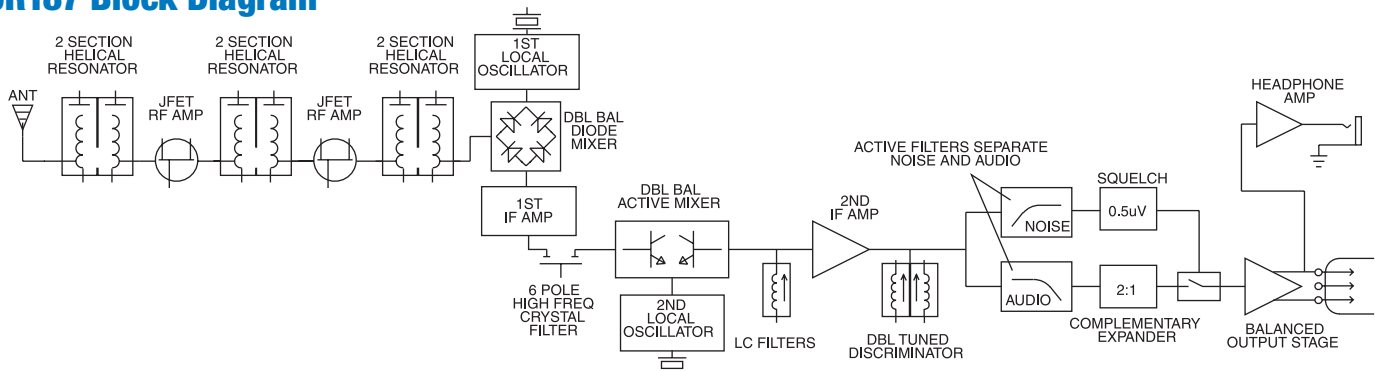

Controls and Functions

Side and Front Panels

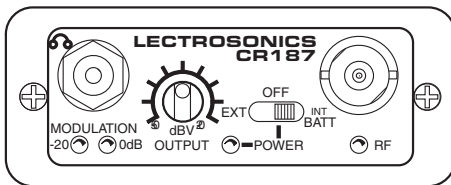

Modulation LEDs

The Modulation LEDs indicate the audio level of the incoming signal. The -20 LED glows when the transmitter modulation is at a high enough level to produce a good audio signal-to-noise ratio. The 0 dB LED indicates the transmitter modulation is at maximum. If both the -20 and 0 dB LEDs are glowing constant, this indicates the transmitter's gain is set too high. It is normal and desirable that you see the -20 LED glowing with an occasional flicker of the 0 dB lamp in typical use.

Mini Phone Jack

The Miniphone Jack provides a audio monitor, separate from the rear panel XLR audio output. The output level from this jack is controlled by both the front panel OUTPUT control and the Headphone Level trim-pot on the side panel. Generally, the front panel OUTPUT control would be set to provide the proper output level at the rear panel XLR jack, then the side panel trim-pot is adjusted to match the required level for your headphones.

The output at this mini connector is designed for a medium impedance headphone/earphone. An impedance between 30 and 300 Ohms will usually provide adequate volume. The sound from a low impedance headphone (i.e.. 8 Ohms) will not be very loud and may be distorted at higher listening levels.

Output Control

Attenuates the audio output level of the receiver to match the input requirements of the equipment with which it is used. The XLR output jack on the rear panel provides an audio output at microphone level for low impedance, balanced inputs. At the extreme counterclockwise position of the OUTPUT control, the output level of this XLR jack will be -50 dB at full modulation. In the fully clockwise position, the output level will be -20 dB at full modulation.

EXT/OFF/INT Switch

The EXT/OFF/INT switch turns the receiver power off and on and selects either internal 9 Volt battery power, or an external 12 VDC power source (of either polarity).

Power LED

The Power LED glows when adequate power is supplied from either the internal battery or an external source. If this LED is very dim or does not light up when the switch is turned on, replace the battery or check the connections from the external power source.

The Power LED is connected to a precision battery test circuit that continuously monitors battery voltage. It is at full brightness with a new 9 VDC alkaline battery. As the battery voltage drops during use, the LED brightness will also decrease. After 4 to 5 hours, the battery voltage will be about 7 volts and the LED will be completely extinguished. From 6.5 volts to 6 volts, the receiver will still operate, but with degraded performance. Below 6 volts, the regulated and temperature compensated squelch circuit will cease to be regulated.

Warning: When the battery voltage drops below 6 Volts, the power LED will remain off, but the other three LEDs (-20 0dB and RF) will light up and a loud rush of audio noise will be heard as the squelch opens. This condition is normal, and is easily remedied by replacing the battery.

RF LED

The RF LED glows when the associated transmitter is turned on and the receiver has a good signal. When the carrier signal from the transmitter is too weak to produce a clean audio signal, this lamp will go out as the squelch engages and mutes the audio.

Antenna Terminal

The Antenna Terminal can be connected to any VHF antenna with a bandwidth that covers the frequency of the receiver and terminates with a 50 ohm BNC type connector. A flexible whip antenna is supplied.

Headphone Level Adjustment

This recessed trim-pot on the side panel is a secondary level control for the mini jack output on the front panel. It does not affect the main XLR output on the rear panel. Normally the main output level is set to match the camera, mixer or recorder, which also affects the output of the mini jack. Then the headphone level is adjusted with this trim-pot for a comfortable listening level.

Receiver Rear Panel

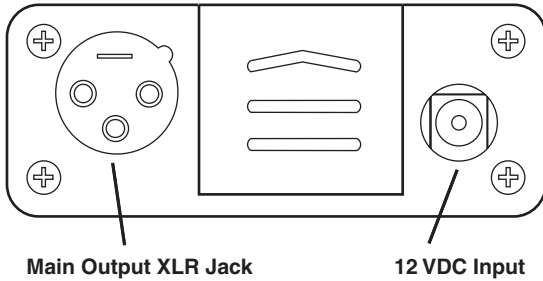

Audio Output XLR Jack

The Audio Output XLR Jack supplies a balanced, low impedance output at microphone level. The audio signal is output on pins 2 and 3, while pin 1 is ground. The output level of this jack is controlled by the OUTPUT control on the front panel of the receiver.

12 VDC Input

The 12 VDC Input connects to the supplied CH-12 AC adapter for powering the receiver from a 110/120V AC source. The receiver may also be powered from other external 12 VDC sources using the correct plug (Switchcraft S-760 power plug). Although the CR187 is a negative ground device, a diode bridge is used in the external power input, so that the CR187 will operate properly from either polarity.

Warning: Because the CR187 is a negative ground device, do not connect this receiver to a positive ground device through the audio cabling. Damage to either device could result.

Battery Replacement

The CR187 is powered by a standard alkaline 9 volt battery. It is important that you use ONLY an ALKALINE battery for longest life. Standard zinc-carbon batteries marked "heavy duty" or "long-lasting" are not adequate. They will provide only about one hour of operation. Similarly, nicad rechargeable batteries give less than 2 hours of operation, and will also run down quite abruptly. Alkaline batteries provide about 5 hours of operation.

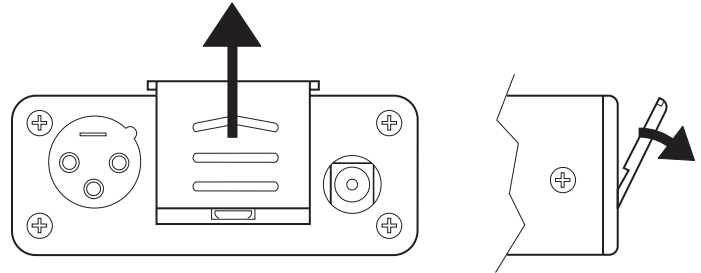

To open the battery compartment, press outward on the cover door in the direction of the arrow as shown in the drawing. Only slight, sliding pressure is needed to open and close the battery door. Swing the door open and take note of the polarity marked inside showing the location of the positive (+) and negative (-) terminals. Insert the battery and close the cover by pressing in and across, reversing the opening procedure outlined above. Note that the battery door will NOT close if the battery is inserted incorrectly, since the terminals will hit a protective polarity barrier. Do not force the battery in.

Operating Instructions

- 1) Connect the power cord or install the battery. (The CR187 is a negative ground device. Do not connect this receiver to a positive ground device through the audio cabling. Damage to either device could result.)
- 2) Attach and extend the antenna.
- 3) Connect the audio cable.
- 4) Set the front panel switch to either "EXT" or "INT", depending upon the power source. Check to see that the red POWER LED lights up.
- 5) THIS IS CRITICAL STEP IN THE SET UP PROCEDURE TO ACHIEVE OPTIMUM SIGNAL TO NOISE RATIO. Adjust the transmitter "gain" for full modulation and slight limiting on signal peaks. See your transmitter manual for specific directions on the proper gain adjustment of your transmitter.
- 6) Adjust the output control according to the type of input on your equipment. The input levels on different VCR's and PA equipment vary, which may require that you set the OUTPUT control in an intermediate position. Try different settings and listen to the results. If the output of the receiver is too high, you may hear distortion or a loss of the natural dynamics of the audio signal. If the output is too low, you may hear steady noise (hiss) along with the audio. The CR187 output was designed to drive microphone level inputs. The output signal level ranges from -50dBV with the output control fully counter clockwise to -20dBV with the output control fully clockwise.



On the M187 transmitter, the MIC LEVEL control and LEVEL and LIMIT LEDs are used to set the input gain for optimum signal to noise ratio.



On the H187 transmitter, the LEVEL control on the rear panel and LEVEL and LIMIT LEDs on the top panel next to the input connector are used to set the input gain for optimum signal to noise ratio.

Antenna Use and Placement

Connect the antenna to the front panel jack. Position the antenna so that it is not touching any metallic surfaces. It is also good to position the receiver so that there is a direct “line of sight” between the transmitter and the receiver antenna. In situations where the operating range is less than about 50 feet, the antenna positioning is much less critical.

A wireless transmitter sends a radio signal out in all directions. This signal will often bounce off nearby walls, ceilings, etc. and a strong reflection can arrive at the receiver antenna along with the direct signal. If the direct and reflected signals are out of phase with each other a cancellation may occur. The result would be a “drop out.” A drop out sounds like either audible noise (hiss), or in severe cases, may result in a complete loss of the carrier and the sound. Moving the transmitter even a few inches may eliminate it. A dropout situation may be either better or worse as a crowd fills and/or leaves a room, or when the transmitter or receiver is operated in a different location.

Dropouts can be avoided by careful placement of the receiver. If you are mounting the receiver on a video camera or camcorder, experiment with the location prior to going into the field. By placing the antenna above the body of the camera, you will increase your operating range. If the antenna is laid next to the camera, as shown in the illustration below, the body of the camera will serve as a shield and reduce range. This position may work but be certain at least part of the antenna extends above the camera.

If dropouts occur in the field, moving the transmitter or receiver slightly in any direction will usually eliminate the problem.

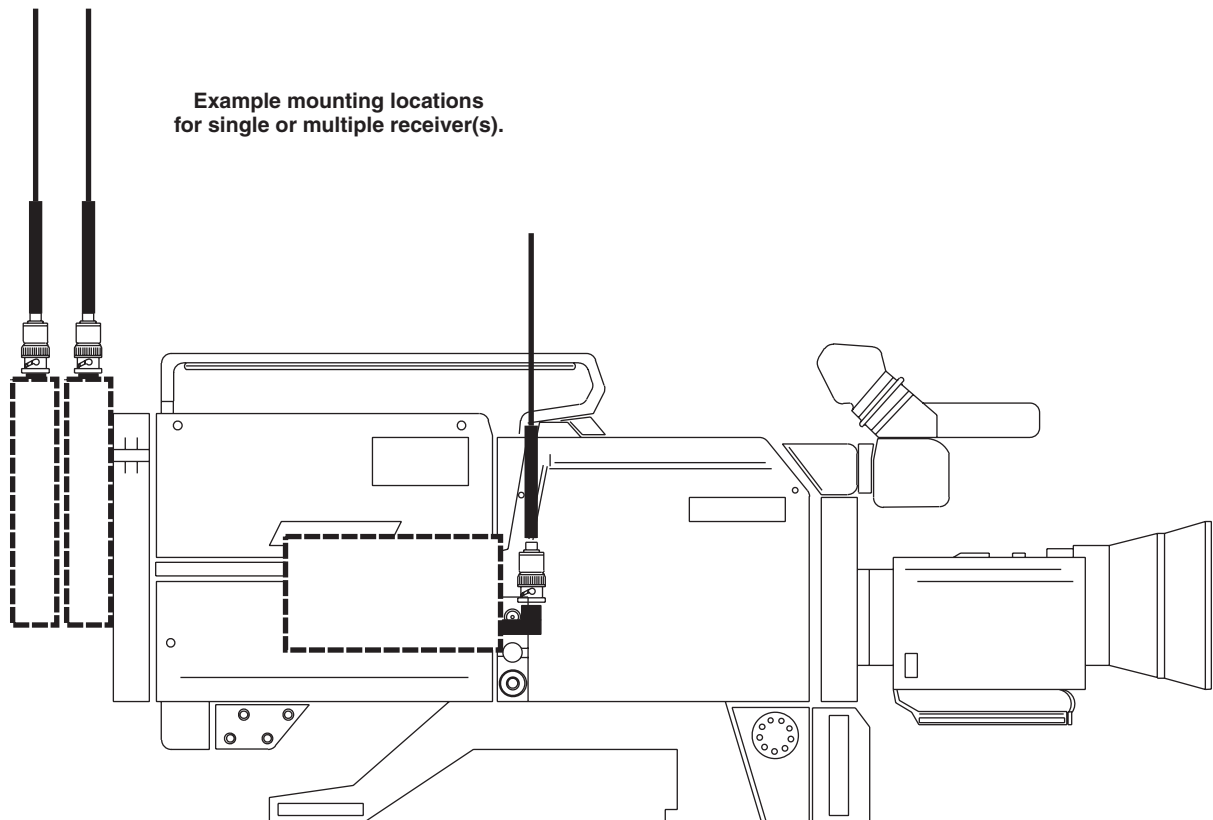

Troubleshooting

Before proceeding, ensure that you have a good battery in the receiver (or a properly connected AC adapter) and that the POWER LED is glowing brightly.

SYMPTOM

POSSIBLE CAUSE

NO POWER LED

- 1) Receiver switch in "OFF" position
- 2) Dead or weak battery
- 3) External 12 Volt power disconnected
- 4)CH-12 AC adapter disconnected
- 5) Receiver switch in wrong position for the power source used

NO RF LED

- 1) Transmitter not turned on
- 2) Transmitter battery dead
- 3) No microphone on transmitter (the microphone serves as the antenna)
- 4) Receiver antenna not connected

RF LED ON BUT NO SOUND AND NO MODULATION LEDS

- 1) Transmitter switch in "MUTE" position
- 2) Transmitter microphone not connected
- 3) Microphone switch in "OFF" position
- 4) Possible malfunction in the audio section of the transmitter. See transmitter manual.
- 5) Check transmitter modulation LEDs for possible transmitter problem

MODULATION LED's ON BUT NO SOUND

- 1) Receiver LEVEL control turned down.
- 2) Audio cable disconnected
- 3) Recorder or sound system off, or not properly adjusted.

Replacement Parts and Accessories

| Part No. | Description |
|------------|---|
| CH-12 | 110 Volt AC adapter for CR187 receiver |
| A-185 Coax | Remote, folded-dipole antenna with coaxial cable |
| 35753 | System pouch |
| A-195RA | Helical, flexible (“rubber duckie”) antenna with a 9inch whip and a right angle BNC connector |
| A-185-BNC | Telescoping 1/4 wave whip on a swiveling BNC connector |

Specifications and Features

| | |
|-------------------------------|--|
| Operating Frequencies: | 150MHz to 216MHz, crystal controlled |
| Sensitivity: | Better than 0.6uV for 20dB quieting without compandor; 1.9uV for 50dB S/N ratio with compandor |
| Signal/Noise Ratio: | 102dB A weighted |
| Squelch Quieting: | greater than 100dB |
| AM Rejection: | -60dB (10uV to 0.1 Volts) |
| Modulation Acceptance: | ±15kHz |
| Image and Spurious Rejection: | greater than 100dB |
| Third Order Intercept: | +6dBm |
| Audio Outputs: | XLR: 200 Ohms balanced; 100mV max. Headphone: 2 Volts RMS into 100 Ohms |
| Antenna Input: | BNC; 50 Ohms impedance |
| Controls: | XLR front panel output attenuator control Recessed trim-pot headphone control 3 position power/function switch |
| Indicators: | Red LED for power “ON” (Battery status) 2 LEDs for modulation level “RF” LED for transmitter “ON” |
| Power Requirements: | 12 Volts DC external (either polarity) 110 VAC via CH-12 AC adapter Single 9 Volt alkaline battery |
| Power consumption: | 55mA |
| Battery Life: | 5 hours with alkaline |
| Weight: | 11 ounces including battery |
| Dimensions: | 1.1” x 2.75” x 5.2” |

Specifications subject to change without notice.

Service and Repair

If your system malfunctions, you should attempt to correct or isolate the trouble before concluding that the equipment needs repair. Make sure you have followed the setup procedure and operating instructions. Check the interconnecting cables and then go through the **Troubleshooting** section in this manual.

We strongly recommend that you **do not** try to repair the equipment yourself and **do not** have the local repair shop attempt anything other than the simplest repair. If the repair is more complicated than a broken wire or loose connection, send the unit to the factory for repair and service. Don't attempt to adjust any controls inside the units. Once set at the factory, the various controls and trimmers do not drift with age or vibration and never require readjustment. **There are no adjustments inside that will make a malfunctioning unit start working.**

LECTROSONICS' Service Department is equipped and staffed to quickly repair your equipment. In warranty repairs are made at no charge in accordance with the terms of the warranty. Out-of-warranty repairs are charged at a modest flat rate plus parts and shipping. Since it takes almost as much time and effort to determine what is wrong as it does to make the repair, there is a charge for an exact quotation. We will be happy to quote approximate charges by phone for out-of-warranty repairs.

Returning Units for Repair

For timely service, please follow the steps below:

- A. DO NOT return equipment to the factory for repair without first contacting us by letter or by phone. We need to know the nature of the problem, the model number and the serial number of the equipment. We also need a phone number where you can be reached 8 A.M. to 4 P.M. (U.S. Mountain Standard Time).
- B. After receiving your request, we will issue you a return authorization number (R.A.). This number will help speed your repair through our receiving and repair departments. The return authorization number must be clearly shown on the **outside** of the shipping container.
- C. Pack the equipment carefully and ship to us, shipping costs prepaid. If necessary, we can provide you with the proper packing materials. UPS is usually the best way to ship the units. Heavy units should be "double-boxed" for safe transport.
- D. We also strongly recommend that you insure the equipment, since we cannot be responsible for loss of or damage to equipment that you ship. Of course, we insure the equipment when we ship it back to you.

Mailing address:
Lectrosonics, Inc.
PO Box 15900
Rio Rancho, NM 87174
USA

Shipping address:
Lectrosonics, Inc.
581 Laser Rd.
Rio Rancho, NM 87124
USA

Telephone:
(505) 892-4501
(800) 821-1121 Toll-free
(505) 892-6243 Fax

Web:
www.lectrosonics.com

E-mail:
sales@lectrosonics.com

LIMITED ONE YEAR WARRANTY

The equipment is warranted for one year from date of purchase against defects in materials or workmanship provided it was purchased from an authorized dealer. This warranty does not cover equipment which has been abused or damaged by careless handling or shipping. This warranty does not apply to used or demonstrator equipment.

Should any defect develop, Lectrosonics, Inc. will, at our option, repair or replace any defective parts without charge for either parts or labor. If Lectrosonics, Inc. cannot correct the defect in your equipment, it will be replaced at no charge with a similar new item. Lectrosonics, Inc. will pay for the cost of returning your equipment to you.

This warranty applies only to items returned to Lectrosonics, Inc. or an authorized dealer, shipping costs prepaid, within one year from the date of purchase.

This Limited Warranty is governed by the laws of the State of New Mexico. It states the entire liability of Lectrosonics Inc. and the entire remedy of the purchaser for any breach of warranty as outlined above. NEITHER LECTROSONICS, INC. NOR ANYONE INVOLVED IN THE PRODUCTION OR DELIVERY OF THE EQUIPMENT SHALL BE LIABLE FOR ANY INDIRECT, SPECIAL, PUNITIVE, CONSEQUENTIAL, OR INCIDENTAL DAMAGES ARISING OUT OF THE USE OR INABILITY TO USE THIS EQUIPMENT EVEN IF LECTROSONICS, INC. HAS BEEN ADVISED OF THE POSSIBILITY OF SUCH DAMAGES. IN NO EVENT SHALL THE LIABILITY OF LECTROSONICS, INC. EXCEED THE PURCHASE PRICE OF ANY DEFECTIVE EQUIPMENT.

This warranty gives you specific legal rights. You may have additional legal rights which vary from state to state.

