

DA4

DISTRIBUTION AMPLIFIER MODULE

**OPERATING INSTRUCTIONS
and trouble-shooting guide**

LECTROSONICS, INC.
Rio Rancho, NM

INTRODUCTION

The DA4 is a 2 width module that provides the means to control and distribute an input signal to four balanced, high-current output drivers. Each output has a separate level control. The DA4 can supply up to 20dB of gain, so small signals can be boosted to avoid noise contamination on long cable runs.

TABLE OF CONTENTS

INTRODUCTION	1
GENERAL TECHNICAL DESCRIPTION	2
INSTALLATION	2
FRONT PANEL DESCRIPTION	3
REAR PANEL DESCRIPTION	3
OPERATING INSTRUCTIONS	3
SERVICE AND REPAIR	4
RETURNING UNITS FOR REPAIR	4
SPECIFICATIONS	5
WARRANTY	Back cover

GENERAL TECHNICAL DESCRIPTION

The DA4 provides an electronically balanced and RF filtered, XLR type input, and four electronically balanced and floating, RF filtered outputs. In addition, a Through output is provided to allow the input signal to be passed through the DA4 on to other modules.

The input stage is a unity gain differential amplifier. This stage drives the four level controls. After the level controls, each output signal is sent to an amplifier stage with 20dB of gain. When the signals have been amplified, they are then passed to the output drivers. The output drivers can provide ample current to drive loads as low as 600 ohms to +20dBv levels. These drivers are electronically balanced and floating, as well as RF filtered. They provide most of the advantages of transformer coupled circuits, without the low frequency non-linearities associated with transformers. Should transformers be desired, however, they are available as options.

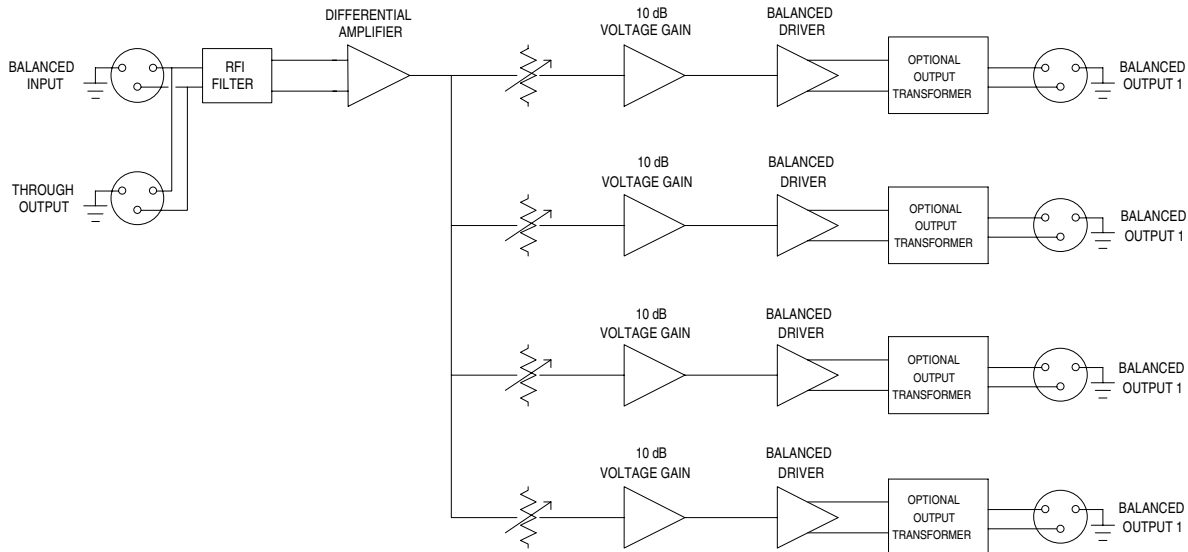

Figure 1 - DA4 BLOCK DIAGRAM

INSTALLATION

The DA4 module is installed from the rear of the Modular Audio Processor mainframe. The printed circuit board can fit into any of the ten slots provided for Modular Audio Processor modules. Once the module is fit into the card guides for the slot, it may be slid forward in the mainframe until the female edge connector seats firmly onto the male pins of the main bus board.

Care should be taken when inserting the edge connector onto the pins to be sure there is correct alignment.

Four #2 machine screws with captive washers are provided to secure the rear panel of the LM3 to the top and bottom rear rails of the Modular Audio Processor mainframe. Four #2 flat head screws are provided to secure the front panel of the LM3 to the front panel of the Modular Audio Processor mainframe. Once these eight screws are in place, the installation of this module is complete.

FRONT PANEL DESCRIPTION

OUTPUT LEVEL (1-4) - Controls the output level for each output. These controls are non-interactive, so all output levels are completely independent.

REAR PANEL DESCRIPTION

INPUT - Accepts a balanced (or unbalanced) input to the module.

THROUGH OUTPUT - Provides an output which is parallel to the input for passing the input signal on to other Modular Audio Processor modules, if desired. Note that since the Through Output is directly in parallel with the input, if an unbalanced input is used, the Through Output signal will be unbalanced also.

OUTPUT (1-4) - Provides low impedance balanced outputs to drive long lines.

OPERATING INSTRUCTIONS

Operation of the DA4 is quite straightforward. A balanced or unbalanced signal is supplied to the input XLR connector. If an unbalanced signal is used, pin 2 ("+") should be connected to the signal or "hot" conductor of the input signal, and pins 1 and 3 should be connected together and also connected to the ground conductor of the input signal. Note that this will make the Through Output unbalanced as well.

With an input signal properly connected, adjust the Output level controls for the desired output level.

The output impedance of the drivers is low (40 ohms balanced) to provide wide band performance over long cable runs. For instance, with a cable capacitance of 30 pico-farads/foot, the outputs can drive well over a mile of cable and still provide frequency response to 20KHz. The formula for calculating the maximum cable run which will still pass signal frequencies to 20KHz is given below:

CC = Cable capacitance/foot

$$\text{Max Cable Length} = \frac{1}{5,026,000 * \text{CC}}$$

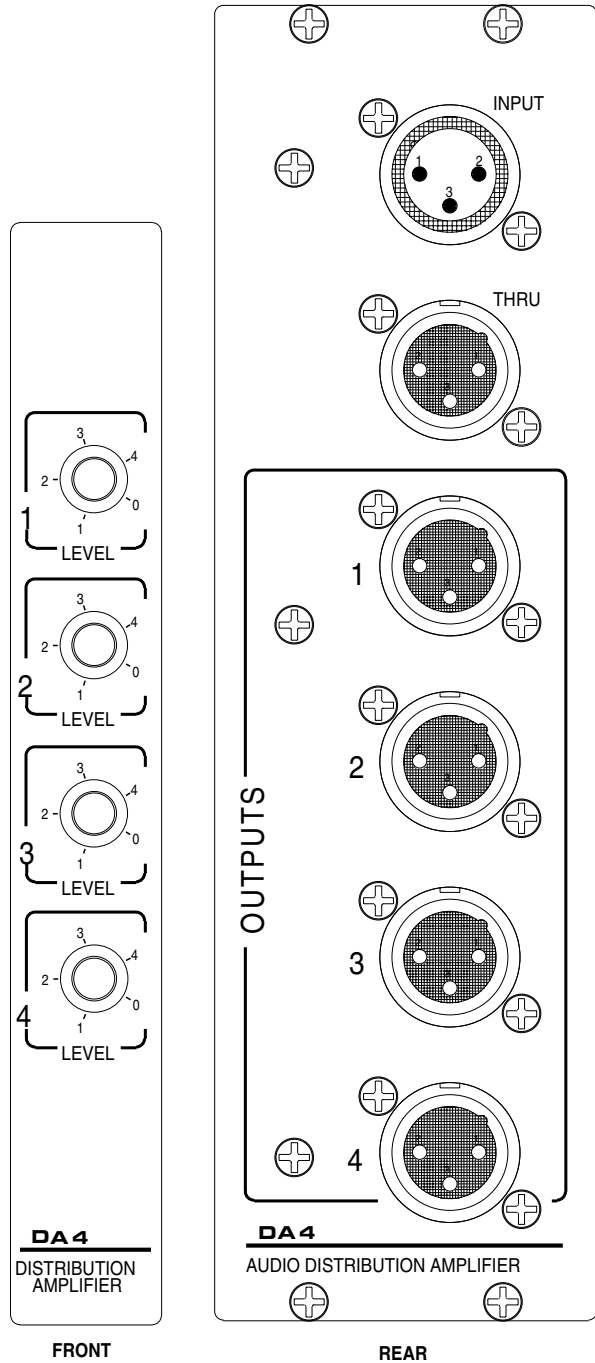

FRONT

REAR

Figure 2 - DA4 FRONT & REAR PANELS

SERVICE AND REPAIR

If your system malfunctions, you should attempt to correct or isolate the trouble before concluding that the equipment needs repair. Make sure you have followed the setup procedure and operating instructions. Check out the inter-connecting cords and then go through the TROUBLE SHOOTING section in the manual

We strongly recommend that you **do not** try to repair the equipment yourself and **do not** have the local repair shop attempt anything other than the simplest repair. If the repair is more complicated than a broken wire or loose connection, send the unit to the factory for repair and service. Don't attempt to adjust any controls inside the units. Once set at the factory, the various controls and trimmers do not drift with age or vibration and never require readjustment. **There are no adjustments inside that will make a malfunctioning unit start working.**

LECTROSONICS service department is equipped and staffed to quickly repair your equipment. In-warranty repairs are made at no charge in accordance with the terms of the warranty. Out of warranty repairs are charged at a modest flat rate plus parts and shipping. Since it takes almost as much time and effort to determine what is wrong as it does to make the repair, there is a charge for an exact quotation. We will be happy to quote approximate charges by phone for out of warranty repairs.

RETURNING UNITS FOR REPAIR

You will save yourself time and trouble if you will follow the steps below:

- A. DO NOT return equipment to the factory for repair without first contacting us by letter or by phone. We need to know the nature of the problem, the model number and the serial number of the equipment. We also need a phone number where you can be reached 8 am to 4 pm (Mountain Standard Time).
- B. After receiving your request, we will issue you a return authorization number (R.A.). This number will help speed your repair through our receiving and repair departments. The return authorization number must be clearly shown on the outside of the shipping container.
- C. Pack the equipment carefully and ship to us, shipping costs prepaid. If necessary, we can provide you with the proper packing materials. UPS is usually the best way to ship the units. Heavy units should be "double-boxed" for safe transport.
- D. We also strongly recommend that you insure the equipment, since we cannot be responsible for loss of or damage to equipment that you ship. Of course, we insure the equipment when we ship it back to you.

Mailing address:
Lectrosonics, Inc.
PO Box 15900
Rio Rancho, NM 87174
USA

Shipping address:
Lectrosonics, Inc.
581 Laser Rd.
Rio Rancho, NM 87124
USA

Telephones:
(505) 892-4501
(800) 821-1121
FAX: (505) 892-6243

World Wide Web: <http://www.lectrosonics.com>

email: sales@lectrosonics.com

SPECIFICATIONS

Maximum Gain:	20dB
THD @ +4dBv, 20-20KHz:	Less than .05%
IMD @ +4dBv, 60/7KHz:	Less than .05%
Noise @ Unity Gain:	20-20KHz Less than -82dBv
Maximum Input Level:	+20dBv
Maximum Output Level:	+20dBv for loads greater the 600 ohms
Input Impedance:	20K ohms, balanced or unbalanced
Input Type:	XLR electronically balanced, RF filtered Pin 2 is "+" input Pin 3 is "-" input Pin 1 is "gnd"
Output Impedance:	40 ohms balanced, 20 ohms unbalanced
Output Type:	XLR electronically balanced and floating RF filtered Pin 2 is "+" input Pin 3 is "-" input Pin 1 is "gnd"

LIMITED ONE YEAR WARRANTY

The equipment is warranted for one year from date of purchase against defects in materials or workmanship provided it was purchased from an authorized dealer. This warranty does not cover equipment which has been abused or damaged by careless handling or shipping. This warranty does not apply to used or demonstrator equipment.

Should any defect develop, we will, at our option, repair or replace any defective parts without charge for either parts or labor. If we cannot correct the defect in your equipment, we will replace it at no charge with a similar new item. We will pay for the cost of returning your merchandise to you.

This warranty applies only to items returned to us, shipping costs prepaid, within one year from the date of purchase.

This warranty gives you specific legal rights. You may have additional legal rights which vary from state to state.

LECTROSONICS, INC.

581 LASER ROAD
RIO RANCHO, NM 87124 USA

August 17, 1996