

EP4

AUTOMATIC MIXER PREAMP MODULE

OPERATING INSTRUCTIONS and trouble-shooting guide

LECTROSONICS, INC.
Rio Rancho, NM

INTRODUCTION

The EP4 Automatic Mic Preamp Module provides balanced, low-noise pre-amplification of signals from microphone to line levels. In addition, the EP4 (in combination with an AC1 Automatic Main Module) implements all necessary functions to perform fully automatic mixing. The EP4 has 3 modes of operation; automatic, priority, and direct. These modes are switch selectable from the front panel.

TABLE OF CONTENTS

INTRODUCTION	1
GENERAL TECHNICAL DESCRIPTION	2
INSTALLATION	4
FRONT PANEL DESCRIPTION	5
REAR PANEL DESCRIPTION	6
OPERATING INSTRUCTIONS	7
REMOTE LEVEL CONNECTIONS	9
TROUBLESHOOTING	10
SERVICE AND REPAIR	11
RETURNING UNITS FOR REPAIR	11
SPECIFICATIONS	12
APPENDIX 1 configuring the Logic Output	13
WARRANTY	Back cover

GENERAL TECHNICAL DESCRIPTION

The microphone preamp of the EP4 uses a modern integrated preamplifier circuit for low equivalent input noise and low distortion. This preamp provides a convenient means for adjusting preamp gain to maximize signal-to-noise ratio for any microphone. This is in contrast to many automatic mixers which employ fixed gain microphone preamps.

The EP4 uses 2:1 expansion rather than abrupt gating to attenuate the channels which have no activity. Maximum attenuation is 15dB. The use of 2:1 expansion results in the total absence of "signal chopping" or other anomalies often associated with automatic mixers that gate. The detection circuitry associated with the expansion function is filtered specifically to respond to energy in the voice range, rejecting both low and high frequency signals. An RMS detector is used to determine channel signal level accurately. The release time constant on each channel can be jumpered to either slow or fast.

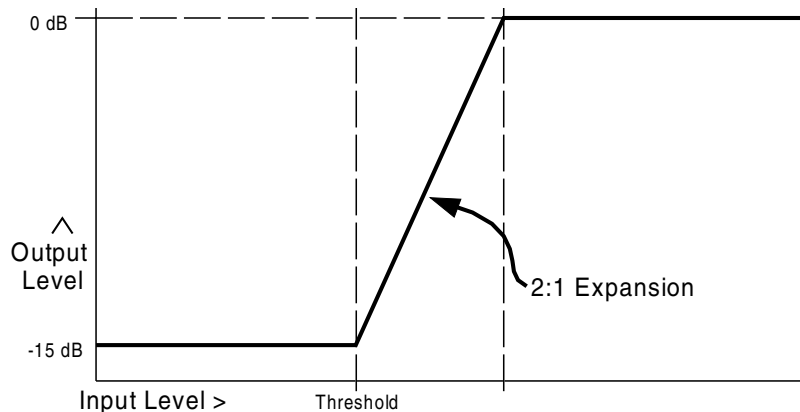

EP4 Expansion Action

Figure 1 - EP4 Expansion

When a signal is presented to an inactive channel, it is compared to the current threshold voltage value. The threshold is a combination of a fixed voltage (set via the Threshold control on the Automatic Control Module) and a variable voltage. This variable voltage consists of a signal proportional to the highest individual channel level at any time. For a system in which only one person is speaking on the system at a time, the mic channel for that person begins to increase in gain when the level exceeds the fixed threshold. As the signal in the channel increases in level, channel gain also increases. When the channel signal level is 15dB above threshold, the channel is at unity gain and no more gain increase happens.

The release time option (fast/slow) represents the time for the channel attenuation to reach 15dB after signal is removed. The fast setting is most useful in situations where background noise is high, because it allows rapid return to full attenuation when signal is not present. This will minimize feed through of background noise into the system. The slow setting is useful for situations where there is not excessive background noise.

Indicators, in the form of LEDs, are provided to indicate the operational status of each channel. A yellow Trim Set LED shows when the trim control is set for optimum performance for any microphone. A green Channel On LED indicates channel activity (defined as channel gain no less than 8dB below unity), allowing simple adjustment of the Threshold control (on the Automatic Control Module).

An optically coupled Logic output is provided on a rear panel terminal strip to indicate when a channel is open. The output may be wired active high or active low, depending on the application.

A line level Send (which is jumperable pre- or post-attenuator) is also provided on the rear panel terminal strip to facilitate recording of individual channels. 48 volt phantom power is supplied to each channel, and can be selected on a channel by channel basis. A 20dB input pad can be selected via jumpers on each channel in order for the EP4 to accept line level signals.

The EP4 has the capability for the level of each channel to be remotely controlled by a potentiometer or switch. In addition, the maximum level of remote attenuation may be selected via a jumper to be 10dB or 70dB.

Other jumperable options include NOM Send In/Out (which allows the channel to operate without affecting the NOM count in the Out position), Variable Threshold Send (which prevents the channel from contributing to the Variable Threshold bus when in the Out position), and Variable Threshold Return (which prevents the channel from responding to signals on the Variable Threshold bus in the Out position). In addition, the signal sent to the Main and Auxiliary internal buses is jumperable pre- or post-attenuator for both buses.

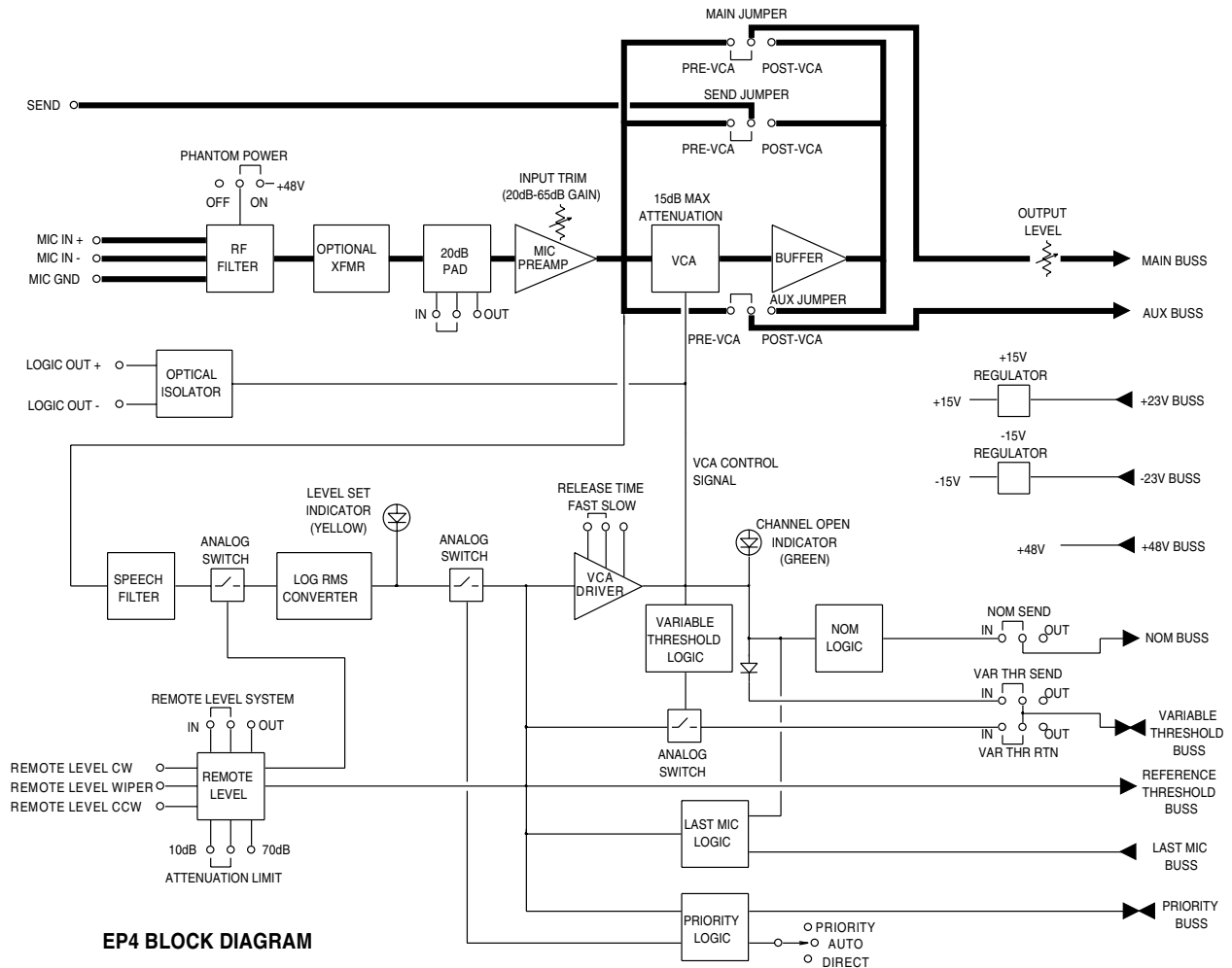

Figure 2 - EP4 Block Diagram

INSTALLATION

Before installing the module, see the Operating Instructions section for guidance as to how to select the various jumperable options on the EP4.

The EP4 is installed from the rear of the Modular Audio Processor mainframe. While the EP4 can slide into any of the ten Modular Audio Processor slots, it is recommended that the EP4 modules be loaded from left to right (facing the front of the mainframe). This will both facilitate microphone cabling to the mic inputs and eliminate unwieldy cable runs from the Main or Aux outputs of the control module. This approach is particularly useful if other Modular Audio Processor system signal processing modules (EQN1, DP1, LE8, etc.) are being used.

The only case in which EP4 modules would not be loaded into the left end of the Modular Audio Processor Mainframe is when any RF modules are in use. RF modules should always be placed in the far left slot(s). Care should be taken when aligning the circuit board with the card guides. Once the module is aligned, slide the card forward in the mainframe until the female edge connector on the module seats firmly onto the male pins of the main bus board. Again, care should be taken to insure proper mating of the connectors.

Four #4 machine screws are provided with the EP4 module. The two screws with captive washers are used to secure the rear panel to the top and bottom rails of the mainframe. After this is accomplished, fit the front panel (also supplied) over the front of the module and secure it, using the two flat-head #4 machine screws, to the front panel of the Modular Audio Processor mainframe. Once these four screws are in place, the installation is complete.

FRONT PANEL DESCRIPTION

INPUT TRIM - Controls the gain of the microphone preamp. Mic preamp gain ranges from 20dB to 65dB. This range is more than sufficient to accommodate all types of microphones. This control is before the level sensing automatic circuitry, and will affect the relative sensitivity of the automatic action. Maximum gain occurs when this control is fully clockwise. Note that if the 20dB pad is jumpered into the signal path, the gain range is from 0dB to 45dB.

OUTPUT LEVEL - Controls the level of signal from the channel sent to the Main bus. This control is after the level sensing and attenuation circuitry, and will not affect the sensitivity of the automatic action. Maximum gain occurs when this control is fully clockwise.

TRIM SET LED - Indicates proper adjustment of the Input Trim control. The Input Trim control should be adjusted until the Trim Set LED flashes regularly on normal speech input.

CH ON LED - Indicates gain of the channel. The LED illuminates when the channel gain is approximately 8dB below unity. The Threshold control (on the Automatic Control Module) should be adjusted until there is no illumination of the "CH ON" LED because of background noise.

MODE - Selects the operational mode of the channel.

Priority Mode: Activity on priority channels fully attenuates non-priority channels. There is no limit to the number of priority channels for a system. Activity on priority microphones will not effect channels in the Direct Mode.

Auto Mode: Channel functions as an automatic channel.

Direct Mode: Channel functions as a standard channel. In this mode, the "CH ON" LED will be on continuously to indicate no channel attenuation under any circumstance.

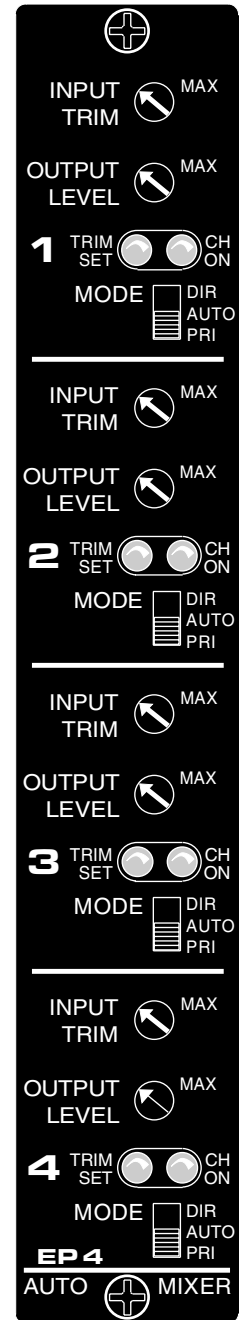

Figure 3 -
EP4 Front Panel

REAR PANEL DESCRIPTION

- MIC INPUT** - Accepts balanced or unbalanced signal. Can accommodate signal levels from mic to line (with 20dB pad). Fully balanced differential input, RF filtered, internally selectable 48 volt phantom supply. Terminal connector position 1 is "+", 2 is "-", and 3 is ground.
- SEND** - Outputs the preamplified, pre- or post-attenuator, pre-channel level signal. For use if recording or other action is desired on a per channel basis. This output is unbalanced. Terminal connector position for the Send output is 4.
- GND** - Provides a ground connection for signal processing equipment used with the Send output. Position 5 on the terminal strip.
- REMOTE LEVEL** - Provides the capability to control the channel level from a remote location using a linear taper pot, switch, or control voltage. Position 6 is the counterclockwise pot connection, position 7 is the wiper connection, and pin 8 is the clockwise pot connection.
- LOGIC OUTPUT** - Provides a logic signal that corresponds to channel "ON" status. Will actuate if the channel is on for any reason, including selection of "Direct" mode. The output is an optically isolated NPN transistor. The "+" output (position 9 on the terminal strip) is connected to the collector of the transistor. The "-" output (position 10 on the terminal strip) is connected to the emitter of the transistor. The device is compatible with normal 5 Volt power, and has a maximum breakdown voltage of 30 Volts. The output can be wired as active high or active low (see appendix 1 for details).

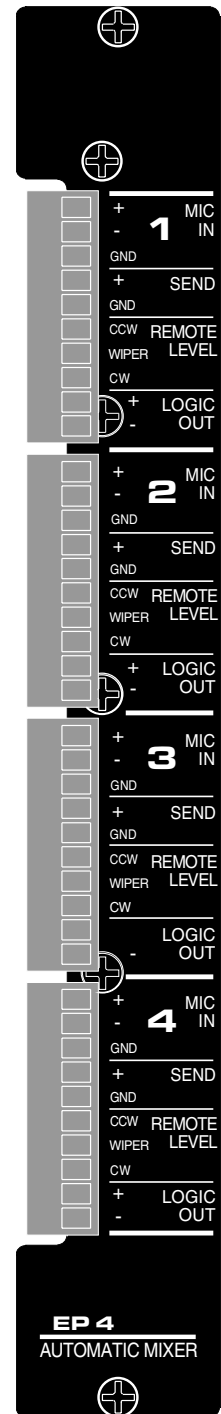
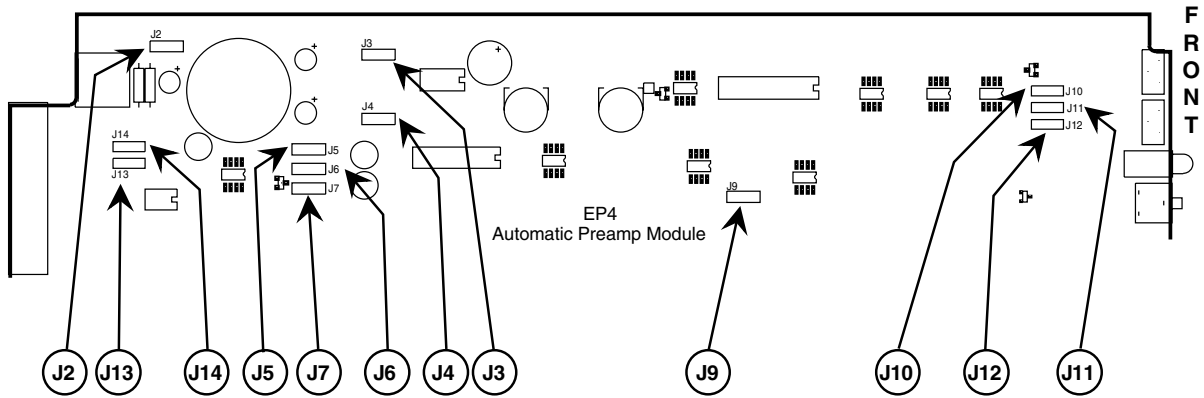

Figure 4 -
EP4 Rear Panel

OPERATING INSTRUCTIONS

The following instructions assume the presence of an Automatic Control Module.

1) Select the proper jumper settings for the application. Figure 5 shows the factory settings of all the jumperable options, along with the jumper positions for each option. A short description of each jumperable option follows:



Factory Jumper Presets					
Function	Jumpers	Preset	Function	Jumpers	Preset
Phantom Power	CH1 - J2	<input type="checkbox"/> OFF <input checked="" type="checkbox"/> ON	Aux Pre / Post VCA	CH1 - J7	<input checked="" type="checkbox"/> PRE <input type="checkbox"/> POST
	CH2 - J16			CH2 - J21	
	CH3 - J29			CH3 - J34	
	CH4 - J42			CH4 - J47	
Remote Level	CH1 - J14	<input type="checkbox"/> OFF <input checked="" type="checkbox"/> ON	Release Time	CH1 - J9	<input type="checkbox"/> SLOW <input checked="" type="checkbox"/> FAST
	CH2 - J28			CH2 - J23	
	CH3 - J54			CH3 - J35	
	CH4 - J55			CH4 - J48	
Attenuation Limit	CH1 - J13	<input type="checkbox"/> 10dB <input checked="" type="checkbox"/> 70dB	Var Thr Return	CH1 - J10	<input type="checkbox"/> OUT <input checked="" type="checkbox"/> IN
	CH2 - J27			CH2 - J24	
	CH3 - J39			CH3 - J36	
	CH4 - J52			CH4 - J49	
20dB Pad	CH1 - J3 / J4	<input type="checkbox"/> IN <input checked="" type="checkbox"/> OUT	Var Thr Send	CH1 - J11	<input type="checkbox"/> OUT <input checked="" type="checkbox"/> IN
	CH2 - J17 / J18			CH2 - J25	
	CH3 - J30 / J31			CH3 - J37	
	CH4 - J43 / J44			CH4 - J50	
Send Pre/Post VCA	CH1 - J5	<input type="checkbox"/> PRE <input checked="" type="checkbox"/> POST	NOM Send	CH1 - J12	<input type="checkbox"/> OUT <input checked="" type="checkbox"/> IN
	CH2 - J19			CH2 - J26	
	CH3 - J32			CH3 - J38	
	CH4 - J45			CH4 - J51	
Main Pre/Post VCA	CH1 - J6	<input type="checkbox"/> PRE <input checked="" type="checkbox"/> POST			
	CH2 - J20				
	CH3 - J33				
	CH4 - J46				

Figure 5 - EP4 Jumpers

Phantom Power - +48V phantom power is provided to the "+" and "-" microphone input terminals. A maximum of 4mA per terminal is available. Factory default is phantom power off.

Remote Level - This jumper selects whether the remote level terminals are active. Set to the "ON" position to use the remote level control capability. Factory default is remote level off.

Attenuation Limit - Allows the selection of the maximum channel attenuation when using the remote level function. Attenuation level limits of 10dB and 70dB are available. Factory default is 70dB.

20dB Pad - To accommodate line level signals, a 20dB pad is provided. With the Input Trim control fully counterclockwise (i.e. minimum preamp gain), the microphone input will accept line level signals up to +20dBu. Factory default is 20dB pad out.

Send Pre/Post - The channel signal sent to the Send output can be jumpered pre- or post-attenuator. The factory default is pre-attenuator.

Main Pre/Post - The channel signal sent to the Main bus can be jumpered pre- or post-attenuator. The factory default is post-attenuator (i.e. normal automatic action)

Aux Pre/Post - The channel signal sent to the Aux bus can be jumpered pre- or post-attenuator. The factory default is pre-attenuator.

Release Time - The release time option (fast/slow) represents the time for the channel attenuation to reach 15dB after signal is removed. The factory default is fast.

Variable Threshold Return - This option prevents the channel from responding to signals on the Variable Threshold bus in the out position. Factory default is in.

Variable Threshold Send - This option prevents the channel from contributing signal to the Variable Threshold bus when in the out position. Factory default is in.

NOM Send - This option prevents the channel from contributing to the NOM count when in the out position. Factory default is in.

Proper setup of the microphone preamp trim levels is important to achieve consistent turn-on performance from each microphone. The trim level procedure is designed to ensure that the same **acoustic level** presented to any microphone in the system will produce the same **electrical signal level** at the output of the microphone preamp. It is especially important to follow the procedure closely when using different types of microphones (which have different sensitivities) in the same installation. After all microphones have been trimmed for equal output, small changes in the trim levels can be made to accommodate such things as the expected differences in talker to microphone distance and the like.

2) Setting Microphone Trim Levels:

- A) Turn on the system using the power switch on the AC1 (Automatic Controller module). Turn the "Last Mic Hold" switch on the AC1 to the ON position. Set the Main Output Level control on the AC1 to "6". The Threshold control should be set to "3". Note that the suggested AC1 settings are only a starting point, and should be finalized based on the particular acoustic situation and system requirements.
- B) Taking each microphone in turn:
 - 1) Set that channel to "Priority". Set the Output Level control to minimum. All other Output Level controls on other channels should be set to minimum, and their Mode should be set to the "Auto" position.
 - 2) Using an audio noise generator (like the Lectrosonics NS1 Noise Generator) or other consistent noise source, generate a 65dB SPL sound level at the microphone.
 - 3) Adjust the Input Trim control until the yellow Trim Set LED lights.
 - 4) Speak normally into the microphone at the expected distance, and adjust the Output Level control for that microphone to achieve the desired sound system loudness. If sufficient loudness is not possible, increase the Input Trim control. If it is necessary to make substantial increases in the Input Trim control, similar adjustments should be made to other channels to maintain a consistent turn-on threshold at all microphones.
 - 5) Reset the channel to the "Auto" position.

REMOTE LEVEL CONNECTIONS

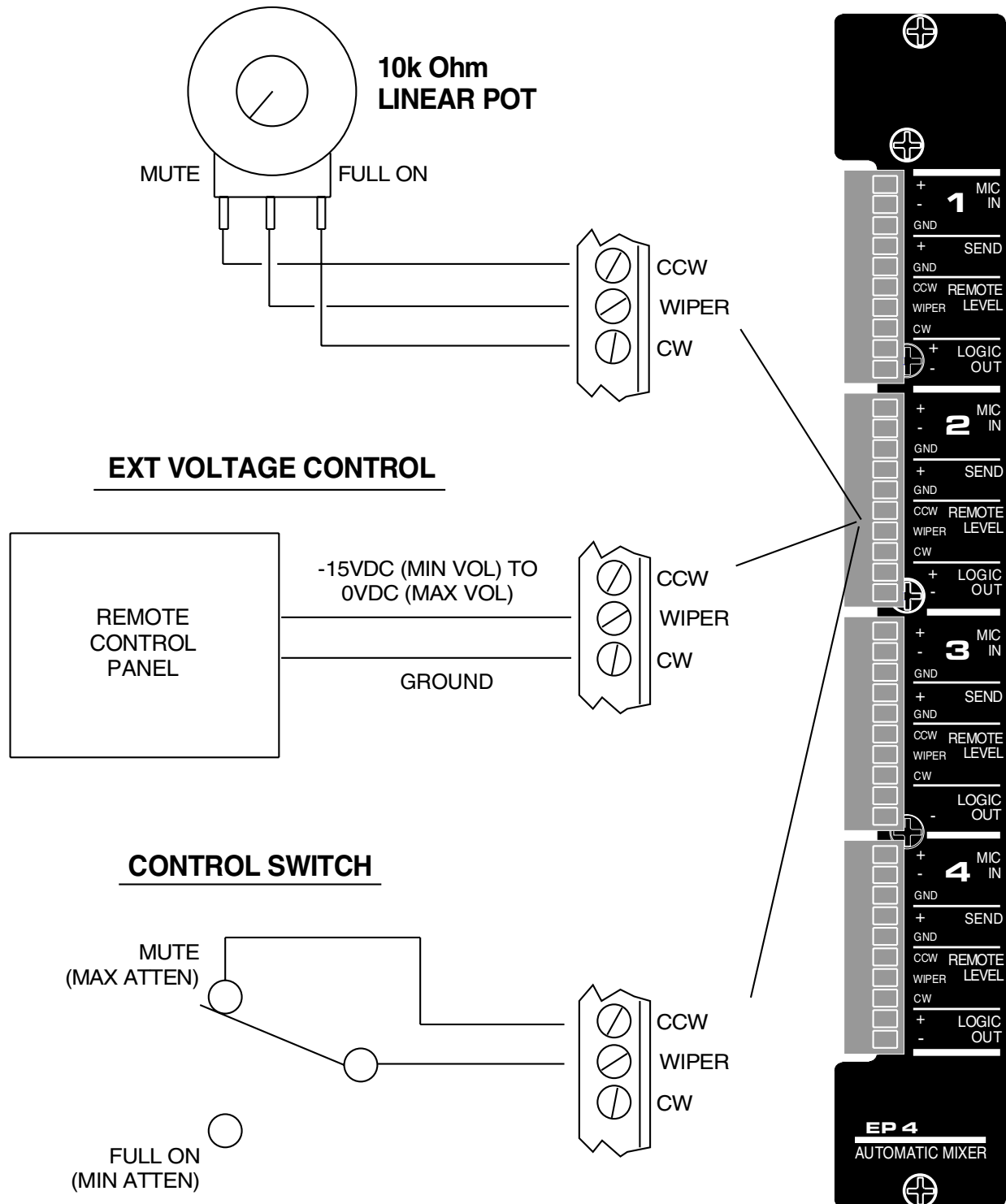

Figure 6 - EP4 Remote Level Connections

TROUBLESHOOTING

SYMPTOM	POSSIBLE CAUSE
1) No sound from system	1) Main level control not turned up 2) Channel level not turned up 3) Input trim not turned up (Does Trim Set LED flash?)
2) Sound "pumps" and is unnatural	1) Threshold on Automatic Control Module is too high (Make sure "CH ON" LED glows brightly during normal speech 2) Last Mic Hold (on AC1 module) should be ON.

SERVICE AND REPAIR

If your system malfunctions, you should attempt to correct or isolate the trouble before concluding that the equipment needs repair. Make sure you have followed the setup procedure and operating instructions. Check out the inter-connecting cords and then go through the TROUBLE SHOOTING section in the manual

We strongly recommend that you **do not** try to repair the equipment yourself and **do not** have the local repair shop attempt anything other than the simplest repair. If the repair is more complicated than a broken wire or loose connection, send the unit to the factory for repair and service. Don't attempt to adjust any controls inside the units. Once set at the factory, the various controls and trimmers do not drift with age or vibration and never require readjustment. **There are no adjustments inside that will make a malfunctioning unit start working.**

LECTROSONICS service department is equipped and staffed to quickly repair your equipment. In-warranty repairs are made at no charge in accordance with the terms of the warranty. Out of warranty repairs are charged at a modest flat rate plus parts and shipping. Since it takes almost as much time and effort to determine what is wrong as it does to make the repair, there is a charge for an exact quotation. We will be happy to quote approximate charges by phone for out of warranty repairs.

RETURNING UNITS FOR REPAIR

You will save yourself time and trouble if you will follow the steps below:

- A. DO NOT return equipment to the factory for repair without first contacting us by letter or by phone. We need to know the nature of the problem, the model number and the serial number of the equipment. We also need a phone number where you can be reached 8 am to 4 pm (Mountain Standard Time).
- B. After receiving your request, we will issue you a return authorization number (R.A.). This number will help speed your repair through our receiving and repair departments. The return authorization number must be clearly shown on the outside of the shipping container.
- C. Pack the equipment carefully and ship to us, shipping costs prepaid. If necessary, we can provide you with the proper packing materials. UPS is usually the best way to ship the units. Heavy units should be "double-boxed" for safe transport.
- D. We also strongly recommend that you insure the equipment, since we cannot be responsible for loss of or damage to equipment that you ship. Of course, we insure the equipment when we ship it back to you.

Mailing address:
Lectrosonics, Inc.
PO Box 15900
Rio Rancho, NM 87174
USA

Shipping address:
Lectrosonics, Inc.
581 Laser Rd.
Rio Rancho, NM 87124
USA

Telephones:
(505) 892-4501
(800) 821-1121
FAX: (505) 892-6243

World Wide Web: <http://www.lectrosonics.com>

email: sales@lectrosonics.com

SPECIFICATIONS

Gain Range:	20dB to 65dB (0dB-45dB with pad)
Maximum Channel Attenuation:	15dB
Equivalent Input Noise, 20-20kHz:	-128dBu
THD, 20-20KHz:	Less than 0.05% (40dB gain, 0dBu out)
IMD, 60/7kHz:	Less than 0.08% (40dB gain, 0dBu out)
Input Impedance:	10K Ω , balanced 5K Ω , unbalanced
Input:	
Type:	Electronically balanced RF filtered
Maximum Input Level	+0dBu (+20dBu with pad) (Gain set at 20dB)
Phantom Power:	+48 Volts, internal jumper
Send (SND) Maximum Output:	+20dBu
Power Consumption:	\pm 200mA at 15 Volts

APPENDIX 1

The Logic Output on each channel of the EP4 is an optically isolated NPN bipolar transistor. This transistor has a breakdown voltage of 30 Volts and will provide a maximum current of about 10mA.

Shown below are two possibilities for configuring the Logic Output, depending on whether an active high or active low signal is desired.

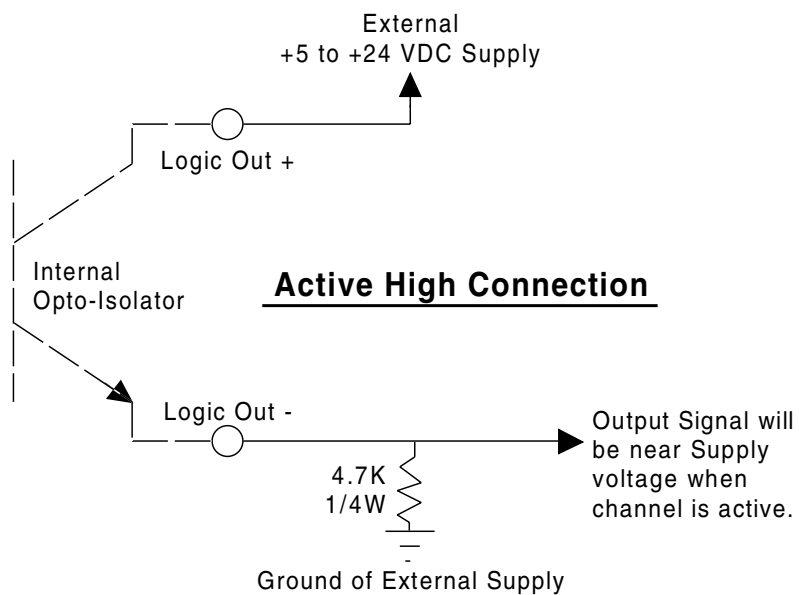
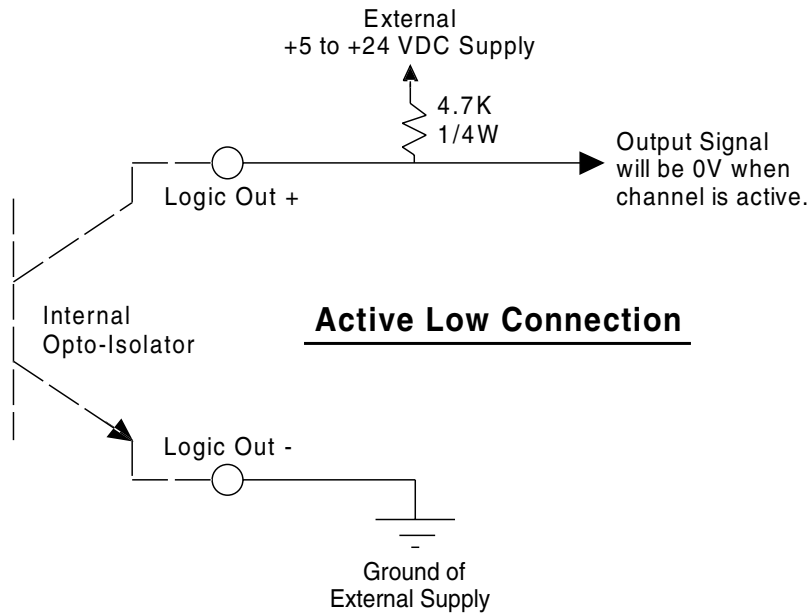

LIMITED ONE YEAR WARRANTY

The equipment is warranted for one year from date of purchase against defects in materials or workmanship provided it was purchased from an authorized dealer. This warranty does not cover equipment which has been abused or damaged by careless handling or shipping. This warranty does not apply to used or demonstrator equipment.

Should any defect develop, we will, at our option, repair or replace any defective parts without charge for either parts or labor. If we cannot correct the defect in your equipment, we will replace it at no charge with a similar new item. We will pay for the cost of returning your merchandise to you.

This warranty applies only to items returned to us, shipping costs prepaid, within one year from the date of purchase.

This warranty gives you specific legal rights. You may have additional legal rights which vary from state to state.

LECTROSONICS, INC.

**581 LASER ROAD
RIO RANCHO, NM 87124 USA**

August 17, 1996