

LCA16

LOGIC CONTROLLED AMPLIFIER*

OPERATING INSTRUCTIONS and trouble-shooting guide

LECTROSONICS, INC.
Rio Rancho, NM

* US PATENT NUMBER 5204908

INTRODUCTION

Thank you for selecting the Lectrosonics LCA16 Logic Controlled Amplifier. The LCA16 is a modular multi-channel amplifier designed to minimize feedback and audio regeneration problems in conference room sound installations using distributed speaker systems. The speakers may be wall mounted, ceiling mounted, table mounted or any combination thereof. For proper operation, the automatic mixer must have logic signal outputs which indicate individual microphone activity.

The LCA16, in conjunction with an automatic mixer (such as the Lectrosonics Modular Audio Processor system) controls the gain of each speaker, individually, in response to activity on any of the microphones in the sound system. Any speaker can be attenuated or turned off completely by the logic output signals from the automatic mixer channels. In addition, each channel includes a balanced line level output which may be used to drive external amplifiers.

Each of the 16 output channels in the LCA16 provides 5 Watts into a 4 Ohm speaker (3 Watts into an 8 Ohm speaker) and a balanced line output. A straight forward switch matrix allows each individual output channel to be attenuated by any combination of the 16 logic inputs.

The LCA16 has integral power supplies and is designed for mounting in a standard 19-inch equipment rack. Three front panel LEDs per channel indicate the level of attenuation. The switch matrix and attenuation level controls are located behind a removable panel to prevent tampering or accidental mis-adjustment.

TABLE OF CONTENTS

INTRODUCTION	1
GENERAL TECHNICAL DESCRIPTION	2
CONTROLS AND FUNCTIONS - FRONT PANEL	3
CONTROLS AND FUNCTIONS - REAR PANEL	5
PRE-CONFIGURING THE LCA16 PRIOR TO INSTALLATION, 16 or FEWER MICS PER LCA16	6
PRE-CONFIGURING THE LCA16 PRIOR TO INSTALLATION, MORE THAN 16 MICS PER LCA16	8
INSTALLATION	10
SYSTEM ADJUSTMENT	12
SPECIFICATIONS	13
SERVICE AND REPAIR	14
RETURNING UNITS FOR REPAIR	14
APPENDIX 1 - POWER LOSS vs CABLE RUN	15
APPENDIX 2 - LCA16 SYSTEM WORKSHEET	16
WARRANTY	Back cover

GENERAL TECHNICAL DESCRIPTION

In the following illustration is a simplified block diagram of the LCA16 showing one amplifier channel. All channels are identical.

The audio input of the LCA16 is an RF filtered, electronically balanced differential amplifier. An AUDIO THRU output is provided so the audio signal can be "daisy chained" to other devices if required. A SIGNAL PRESENT LED on the front panel indicates the presence of signal above -20dBv. The audio signal passes through the MAIN LEVEL control before being distributed to the output channel amplifiers. Each output channel employs a dedicated power amplifier. The amplifiers are fully protected from short circuits, thermal overloads or highly reactive loads. Each amplifier is individually fused, so in the event of catastrophic failure of any single channel, no other channels will be affected. Each output channel also includes a balanced line level output which is simultaneously available to drive external amplifiers, or other audio equipment.

The logic input signal conditioning circuits are specially designed to accept a wide variety of logic signals, ranging from relay contact closures to TTL logic levels. Each logic input passes through a time constant circuit with hysteresis. This guarantees minimum "signal chopping" caused by changing attenuation during pauses in speech. Photo-conductive opto-isolators are employed to switch the level of attenuation of the audio. These devices eliminate the abrupt audible changes that occur when hard switching is used.

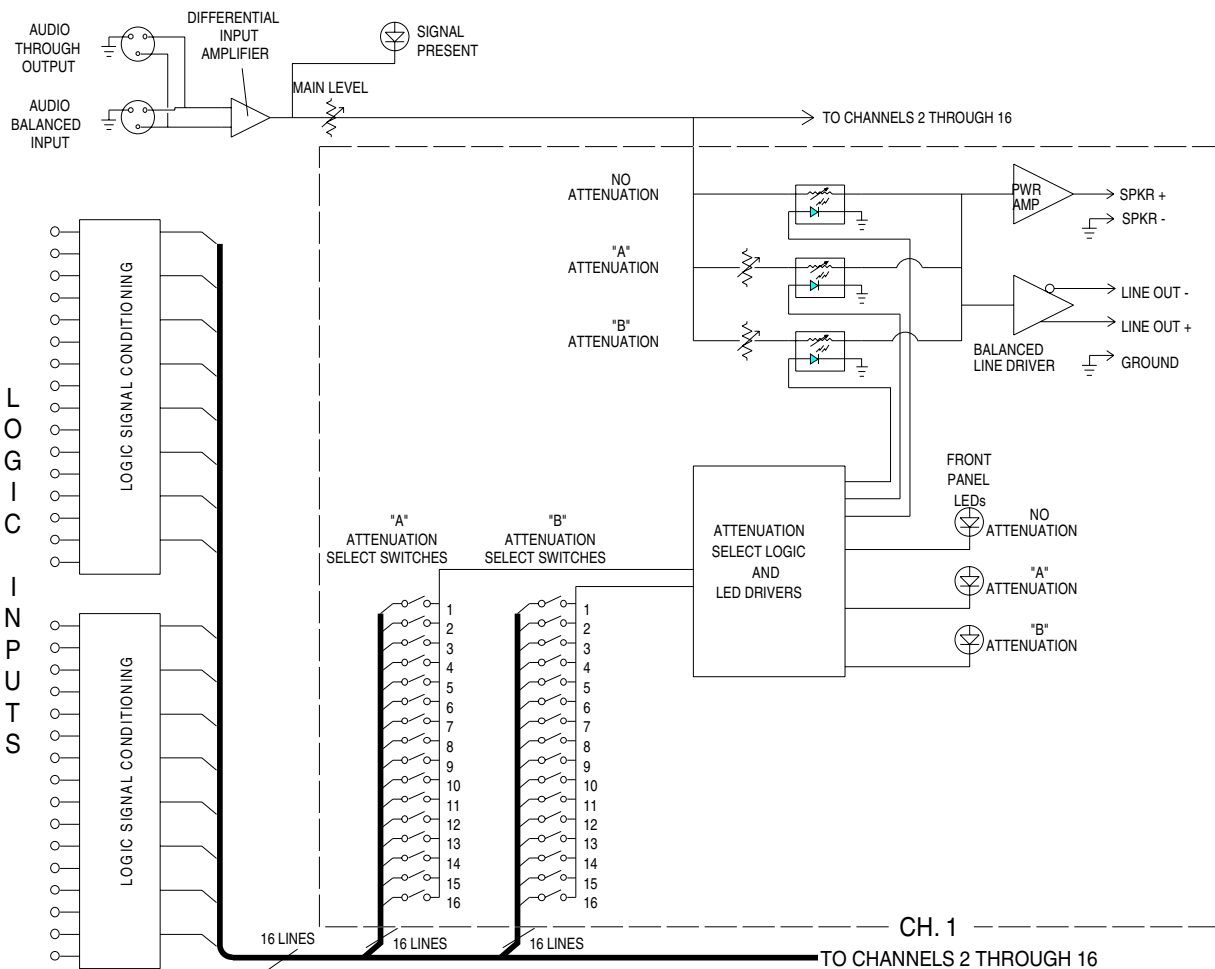

Figure 1 - LCA16 Block Diagram

CONTROLS AND FUNCTIONS - FRONT PANEL

POWER SWITCH

Controls the application of AC power to the LCA16.

POWER LED

Indicates the presence of AC power to the LCA16.

MAIN LEVEL

Controls the overall output level of the sound system.

SIGNAL PRESENT LED

Indicates the presence of audio signal to the LCA16.

ON LED

(Channels 1-16) Indicates the output channel is in the "on" state (not attenuated).

ATTENUATION LEDS

A LED: (Channels 1-16) Indicates the output channel is at the "A" attenuation level.

B LED: (Channels 1-16) Indicates the output channel is at the "B" attenuation level.

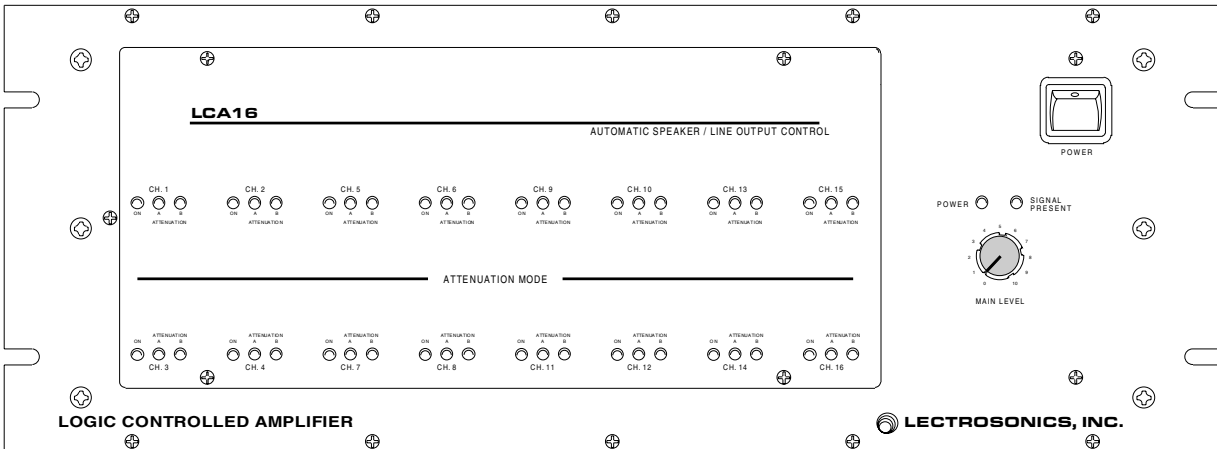

Figure 2 - LCA16 Front Panel

ATTENUATION DIP SWITCHES (located behind front panel cover)

These switches are used to program which microphone (or microphones) connected to the 16 LOGIC INPUTS will trigger the "A" and "B" attenuation levels for each of the 16 output channels. Four banks of switches (eight switches per bank) are allocated to each channel. Two of the switch banks (16 switches) trigger the "A" attenuation level, the other two switch banks trigger the "B" attenuation level. The switch number is printed on the circuit board alongside the switch assemblies (disregard the numbers printed on the switch assembly itself).

ATTENUATION LEVEL CONTROLS (located between the DIP switch assemblies)

These control the amount of "A" and "B" level attenuation for each output channel. "A" level attenuation always takes priority over "B" level attenuation and, therefore, the "A" control must always be set to a higher setting than the "B" control.

An enlarged view of the speaker #7 and #8 sections of the attenuation selection DIP switches and attenuation level controls is shown below. The attenuation select switches provide the means to select which microphones will attenuate each speaker and to what attenuation level. The output of each speaker amplifier may be attenuated from 0dB to completely off by means of the two continuously variable preset adjustment potentiometers ("A" and "B"). Therefore, each speaker may be attenuated by one or more microphones on either (or both) of the "A" or "B" levels as shown in the examples on page 7 and 8.

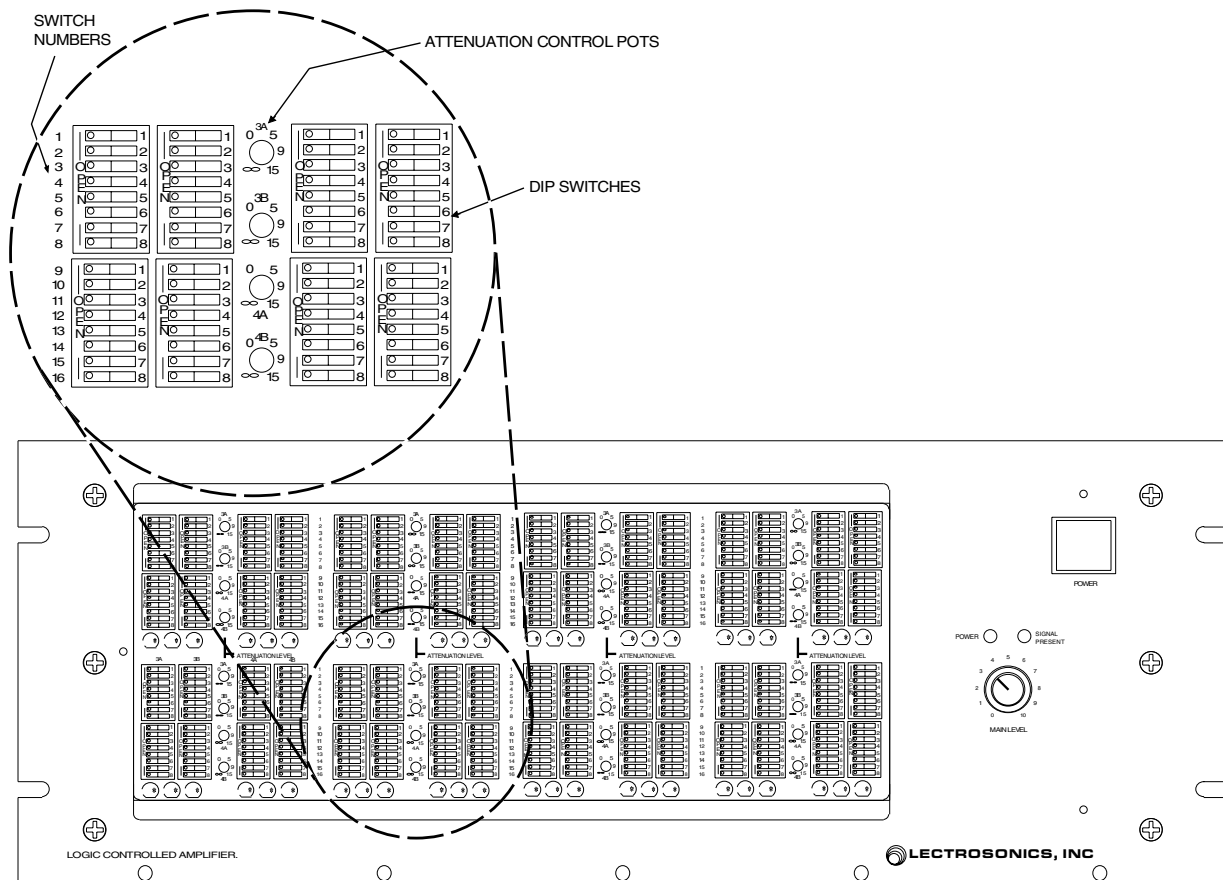

Figure 3 - Dip Switch Detail

CONTROLS AND FUNCTIONS - REAR PANEL

SPKR OUT

Connects to the individual speakers in the sound system. SPKR OUT (+) is the "hot" terminal, and SPKR OUT (-) is ground.

LINE OUT +/-

Provides balanced line level drive to external amplifiers or other equipment. The LINE OUT signal is attenuated identically to its associated speaker output. Output impedance is 600 ohms, and is suitable for driving both low and high impedance inputs.

LINE OUT \perp

Provides the ground connection for the balanced line driver.

LOGIC INPUTS

Connects to the logic outputs of an automatic mixer, or to other types of contact closure. Logic Input (+) connects to the (+) terminal of logic output on an automatic mixer, and the Logic Input (-) is ground.

AUDIO INPUT

Receives the audio signal for the sound system. This input is electronically balanced and RF filtered, and uses a standard 3 pin XLR female connector.

AUDIO THRU

Outputs the signal received by the Audio Input for daisy chaining applications. This output is directly in parallel with the AUDIO INPUT.

FUSE

Protects the unit in case of internal overload. Replace only with a 1.5 amp slow blow fuse.

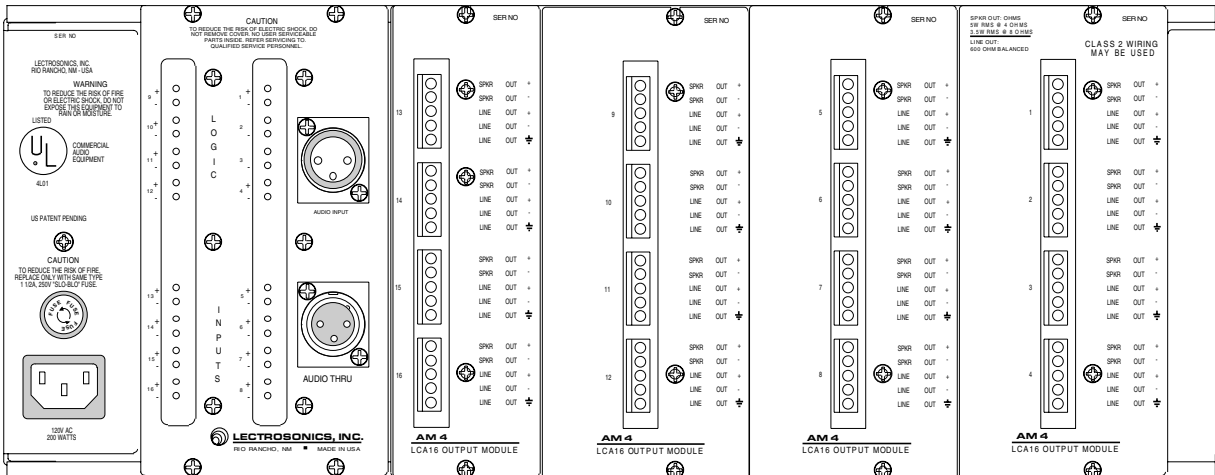

Figure 5 - LCA16 Rear Panel

PRE-CONFIGURING THE LCA16 PRIOR TO INSTALLATION, 16 or FEWER MICS PER LCA16

This procedure should be performed prior to installation. The LCA16 SYSTEM WORKSHEET (Appendix 2) will assist you in setting up the LCA16 before going on site. While the actual setup is quite simple, it is recommended that you use this worksheet, especially if this is your first installation using the LCA16 Logic Controlled Amplifier.

Using the LCA16 SYSTEM WORKSHEET

PROCEDURE 1 - Use this procedure if you have 16 or fewer microphones per LCA16 in this installation. This procedure assumes a 1:1 relationship between microphones and logic terminals. If you have more than 16 microphones per LCA16, then skip this section and use procedure 2.

To fill out this chart, you need a floor plan of the room showing both speaker and microphone placement. See below for an example of a floor plan with notations showing mics, speakers, and attenuation zones.

STEP 1 - On your floor plan, assign consecutive numbers to each microphone, starting with #1.

STEP 2 - Assign consecutive numbers to each speaker on the floor plan, again starting with #1.

STEP 3 - On your LCA16 SYSTEM WORKSHEET, assign the microphones to logic inputs in the first column on the left. Simply transfer the microphone numbers from your floor plan to the crossed boxes. See Example 1.

STEP 4 - Assigning Attenuation Levels In this step you will be noting in each box how much the speakers will be affecting each microphone.

4A Start with the box where the SPEAKER 1 column intersects the microphone 1 (logic input 1) row. Check your floor plan. If speaker 1 will be a potential source of feedback for microphone 1, then mark that box. Use an "A" for speakers which are very close to the microphone and a "B" for those which are located further from the microphone. While still referring to the floor plan, move down to the next box in the speaker 1 column where it intersects the microphone 2 row. If speaker 1 will also affect microphone 2, then mark that box accordingly.

If this speaker will have no effect, then leave the box blank.

4B Repeat this step for every box in the grid where a speaker and microphone/logic input intersect.

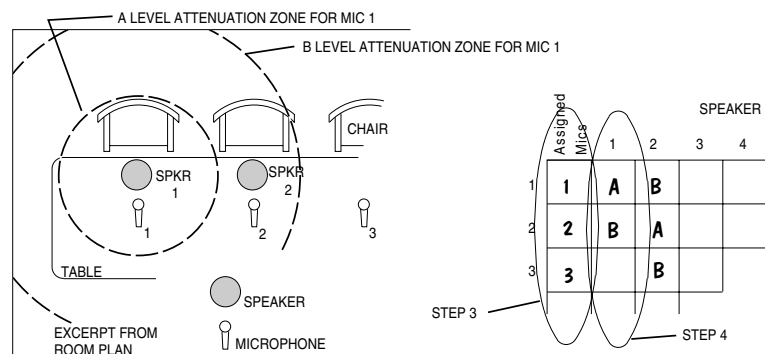

Figure 6 - Example 1

STEP 5 - Setting the DIP switches Upon completion of the chart you will have a grid which can now be used for setting the DIP switches on the LCA16. See Example 2 below. Each speaker output on the LCA16 has a set of dip switches on the front panel. There are two banks of 16 switches aligned vertically above a set of LED indicators. The left bank of switches is for "A" level attenuation. The right bank of switches is for "B" level attenuation. DIP switches are set to the ON position by depressing them to the right. You will set these switches according to the A and B notations on your LCA16 SYSTEM WORKSHEET.

For example, according to the worksheet in Example 2, speaker 1 has two microphones which it affects. Speaker 1 will need to be attenuated to "A" level for microphone 1 and attenuated to "B" for microphone 2.

Speaker 2 will need to be attenuated to "B" level for microphones 1 and 3 and attenuated to "A" level for microphone 2.

The illustrations below indicate how the switches will need to be set according to the worksheet.

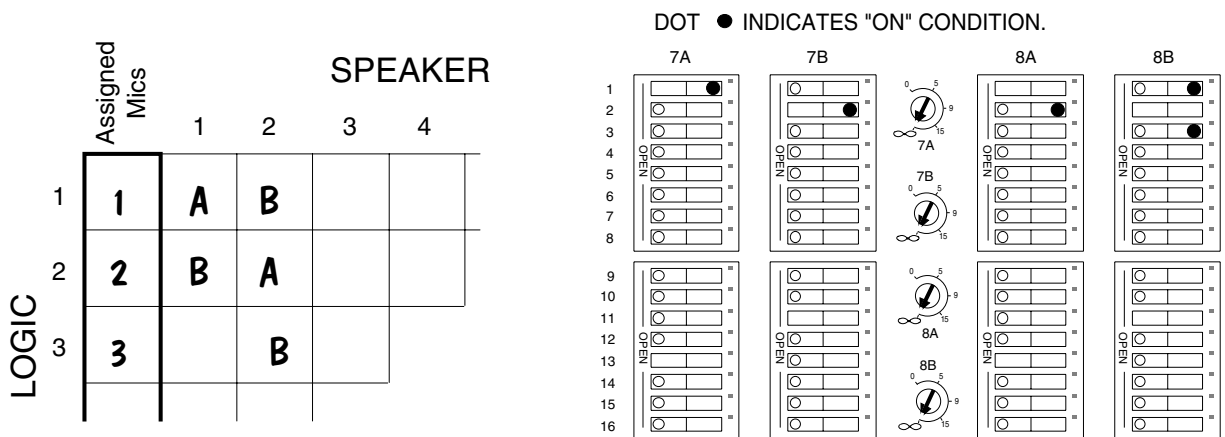

Figure 7 - Example 2

STEP 6 - Make your initial settings for the "A" and "B" levels of attenuation. If you have not yet determined a starting level of attenuation for your speakers, it is suggested that all "A" levels be set for full attenuation (completely off) and the "B" levels set for 5 to 9dB of attenuation. PLEASE NOTE THAT THE "A" LEVEL WILL ALWAYS TAKE PRIORITY OVER "B" LEVEL, SO BE CERTAIN THE "A" LEVEL IS SET TO THE GREATER ATTENUATION.

The levels of attenuation are set by adjusting the small recessed pots found between each pair of output channel DIP switches located on the front panel. See the illustration above. These controls are set with a small screwdriver (provided with the LCA16). Fully clockwise sets the channel to completely off. Set all active channels.

The LCA16 is now pre-configured and may be installed in the rack. Proceed to page 10, INSTALLATION.

PRE-CONFIGURING THE LCA16 PRIOR TO INSTALLATION, MORE THAN 16 MICS PER LCA16

PROCEDURE 2 - Use this procedure for those installations where there are more microphone channels than logic inputs.

The only difference between this setup and the setup described previously is that you have assigned multiple microphones to the same logic input because they are affected by the same group of speakers. This practice is only necessary when the number of microphones exceeds the number of logic inputs in the installation.

Using the LCA16 SYSTEM WORKSHEET

To fill out this chart, you will need a floor plan of the room showing both speaker and microphone placement. See below for an example of a floor plan with notations showing mics, speakers, and attenuation zones.

STEP 1 - On your floor plan, assign consecutive numbers to each microphone, starting with #1.

STEP 2 - Assign Consecutive numbers to each speaker on the floor plan, again starting with #1.

STEP 3 - This step is critical for assigning multiple microphones to the same logic input. As you look at your floor plan, check to see which microphones will be affected by **exactly** the same speakers. These microphone channels can be wired to the same logic inputs. For example, if microphones 1 and 2 are both affected by the same speaker, then you can assign both mics to logic input 1 (see Example 3). These logic input assignments will assist you when wiring the twisted pair wires from your logic connections on the automatic mixer to the logic connections on the LCA16. Repeat this step for each group of microphones.

STEP 4 - Assigning Attenuation Levels. In this step you will be noting in each box how much the speakers need to be attenuated.

4A Start with the box where the SPEAKER 1 column intersects the logic input 1 row. Check your floor plan. If the speaker 1 will be a potential source of feedback for microphone 1, then mark that box. Use an "A" for speakers which are very close to the microphone and a "B" for those which are located further from the microphone. While still referring to the floor plan, move down to the next box in the speaker 1 column (where it intersects with logic input 2). If speaker 1 may also be a source of feedback for the mics assigned to logic input 2, then mark that box accordingly.

If it is unlikely that feedback will occur, then leave the box blank.

4B Repeat this step for every box in the grid where a microphone/logic input row and a speaker column intersect.

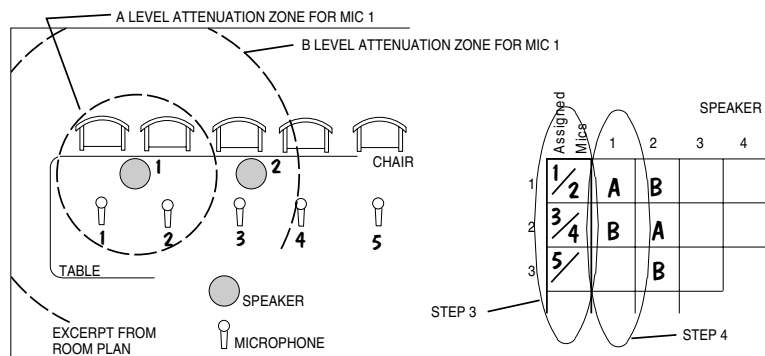

Figure 8 - Example 3

STEP 5 - Setting the DIP switches Upon completion of the chart you will have a grid which can now be used for setting the DIP switches on the LCA16. See Example 4 below. Each speaker output on the LCA16 has a set of DIP switches on the front panel. There are two banks of 16 switches aligned vertically above each LED bank. The left bank of switches is for "A" level attenuation. The right bank of switches is for "B" attenuation. DIP switches are set to the ON position by depressing them to the right. You will set these switches according to the notations written on your LCA16 WORKSHEET.

For example, according to the worksheet in Example 4, speaker 1 is attenuated by two logic inputs. Speaker 1 will need maximum attenuation ("A" level) for logic input 1 (microphones 1 and 2) and partial attenuation ("B" level) for logic input 2 (microphones 3 & 4).

Speaker 2 will need to be attenuated partially ("B" level) for logic inputs 1 and 3 and fully attenuated ("A" level) for logic input 2.

The illustrations below show how the switches will need to be set according to the chart.

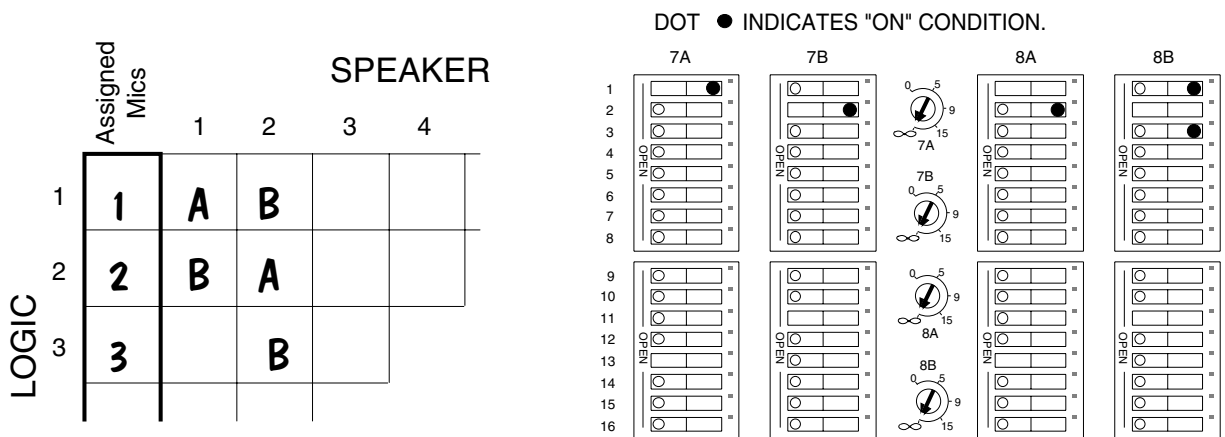

Figure 9 - Example 4

STEP 6 - Make your initial settings for the "A" and "B" levels of attenuation. If you have not yet determined a starting level of attenuation for your speakers, it is suggested that all "A" levels be set for full attenuation (completely off) and the "B" levels set for 5 to 9dB of attenuation. PLEASE NOTE THAT THE "A" LEVEL WILL ALWAYS TAKE PRIORITY OVER "B" LEVEL, SO BE CERTAIN THE "A" LEVEL IS SET TO THE GREATER ATTENUATION.

The levels of attenuation are set by adjusting the small recessed pots found between each pair of output channel DIP switches located on the front panel. See the illustration above. These controls are set with a small screwdriver (provided with the LCA16). Fully clockwise sets the channel to completely off.

The LCA16 is now pre-configured and may be installed in the rack. Proceed to page 10, INSTALLATION.

INSTALLATION

The LCA16 is designed to be mounted in a standard 19-inch equipment or cabinet. Adequate ventilation must be provided which can normally be accomplished by leaving at least two open rack spaces (3 1/2 inches) above and below the unit. Generally, the LCA16 should be positioned such that the intake air (from the bottom of the unit) is the coolest available in the rack. If there are fans in the rack for cooling, optimum placement will be determined by the fan position.

INTERCONNECTIONS

Refer to your LCA16 SYSTEM WORKSHEET to see which microphone is connected to each LOGIC INPUT, and which speaker is connected to which output channel. Your room sketch will also be helpful. Number each speaker and microphone and tag the wire pairs. Doing this prior to making any interconnections will save a great deal of time during the initial setup. It is not necessary to install microphones and speakers in any particular order.

Audio Connection from Mixer / Signal Processor

Electrical connection to the AUDIO INPUT is made using a standard 3-pin XLR type connector. Pin 2 is audio "hot" (+), pin 3 is audio "cold" (-), and pin 1 is ground (shield). If an unbalanced source is used for audio input, connect the source ground to pins 1 and 3 at the LCA16, and source "hot" to pin 2. The use of a two-wire plus shield cable is recommended, with the shield left unconnected at the source end and connected to signal ground at the LCA16 end regardless of whether the source is balanced or unbalanced.

Logic Connections From Mixer

Electrical connection to the LOGIC INPUTS is made using stripped and tinned insulated hookup wire, 18 to 24 gauge. If connecting to Lectrosonics' AP4 Modular Audio Processor modules, simply connect the LOGIC OUT (+) of the AP4 to the LOGIC INPUT (+) of the LCA16, and the LOGIC OUT (-) of the AP4 to the LOGIC INPUT (-) of the LCA16. If multiple microphones are assigned to the same logic input, the logic connections may be connected in parallel.

If connection is being made to relay contacts, the polarity of the connection is unimportant. When connecting to the logic outputs of other manufactures' equipment, treat the LOGIC INPUT (-) on the LCA16 as "ground" and the LOGIC INPUT (+) on the LCA16 as "signal" or "hot". Internally, the LOGIC INPUT (+) on the LCA16 is connected through 100k Ohm to +5 Volts, so any logic output or other contact system which is interfaced to the LCA16 must be capable of sinking 50 microamps of continuous current. The LOGIC INPUTS of the LCA16 are active low.

Speaker Connections

Electrical connections to the **SPKR OUT** terminals are made using any two wire cable of 22 gauge or larger. Refer to the table in Appendix 1 for power loss vs cable distance data. The best practice is to tin the leads before insertion into the terminal blocks to eliminate wire "whiskers" that might cause intermittent connections. The **SPKR OUT** terminals drive low impedance loads (4 Ohms and above) directly, making a matching transformer at the speaker unnecessary. The **SPKR OUT +** output terminal is in phase with pin 2 of AUDIO INPUT. The **SPKR OUT -** terminal is connected to system ground. Neither of the output terminals should be connected to any other grounds (e.g. building grounds, cold water grounds, etc.) or to any source of voltage. The only connections that should be made are to the speaker itself.

Line Out to Recorder or External Amplifier

Electrical connections to the LINE OUT terminals can be made in one of two ways, depending on whether a balanced or unbalanced input is to be driven. In both cases a two-wire plus shield type of cable should be used. For driving a balanced input, **LINE OUT +** connects to the signal "hot" (pin 2 on a standard XLR 3-pin connector), and **LINE OUT -** connects to the signal "cold" (pin 3 on a standard XLR 3-pin connector). **LINE OUT** \oplus is connected to the shield of the cable. It is not necessary to connect the shield to anything at the other end of the cable. The connection at the LCA16 end is sufficient for shielding.

With a balanced system, there is no need to connect the grounds together. An additional benefit of this is that the possibility of ground loops will be eliminated. For driving an unbalanced input, **LINE OUT +** is connected to the "signal" terminal of the input to be driven, and the **LINE OUT** \oplus is connected to the "ground" terminal of the input. Note that both "signal" and "ground" should be carried on the two wires of the cable. The shield should be connected to **LINE OUT** \oplus on the LCA16 end and left unconnected on the other end.

INTERCONNECTION DIAGRAM

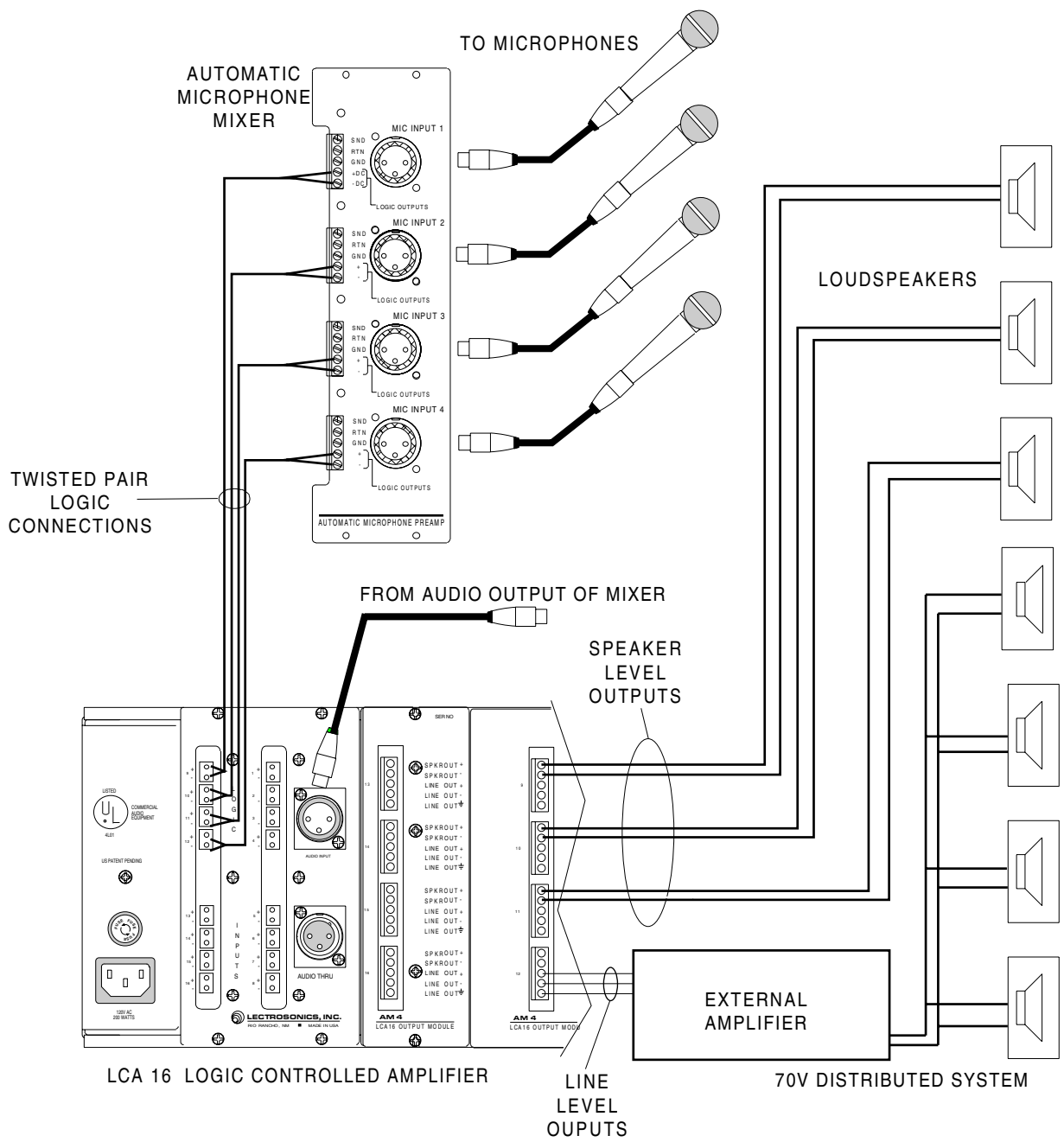

Figure 13 - Interconnection Diagram

ATTENUATION SETTINGS AND SPEAKER SYSTEM ADJUSTMENTS

The steps and procedures in this section should be followed only after all wiring and audio connections have been completed, and the system components have been installed. It is also necessary to complete the worksheet for speaker attenuation and the pre-configuration instructions for the LCA16 before attempting the adjustments in this section.

MAIN LEVEL ADJUSTMENT ON THE LCA16

The pre-configuration instructions on pages 6 through 9 simply provide a "starting point" for further adjustment. The settings suggested in that section are based upon typical experience gathered from the field. The actual settings for a particular system may vary from these settings once the final set up is completed.

Ideally, the LCA16 should provide just enough attenuation to prevent feedback while allowing maximum speaker system coverage. Attenuation beyond what is necessary for feedback control can make the operation of the LCA16 audible as the speaker system attenuates in response to microphone activity. In many installations, the operation of the sound system is almost transparent. In other words, the talkers do not actually hear themselves over the speaker system as they talk, yet adequate reinforcement is provided so that more distant listeners can hear them clearly.

The first step in the final set up is to complete the attenuation settings for a single speaker zone, and then use these settings as a guide for subsequent adjustments. The final adjustment of this first speaker zone will provide a setting for the LCA16 MAIN LEVEL control. Once the MAIN LEVEL control is set for the first speaker zone, it should be left alone for adjustment of the rest of the speaker zones.

Select a zone in the central part of the room and activate a microphone within it. Gradually increase the MAIN LEVEL on the LCA16 until an adequate volume is achieved. **If feedback occurs before adequate gain can be achieved**, increase the attenuation level of the speakers near the open microphone and then continue to increase the sound system level. If additional attenuation is required, it often requires a change in the DIP switch settings indicated by the original worksheet (more speakers may need to be attenuated). Activate each microphone in this zone (if there is more than one) and check for adequate gain. Re-adjust the attenuation levels as needed.

If adequate gain cannot be achieved, even with excessive speaker attenuation, the basic sound system design may be at fault. In this case, it may be time to re-evaluate the mouth to microphone distances and/or the basic microphone and speaker system layout in the room.

If there is more than enough gain, reduce the amount of attenuation of the speakers near the open microphone. Remember that the most transparent operation will be achieved with the least amount of attenuation. Use only enough attenuation to control feedback.

Once adequate gain is achieved on the first zone, leave the MAIN LEVEL control on the LCA16 alone for adjusting the remaining channels.

SETTING ATTENUATION LEVELS ON REMAINING CHANNELS

With the LCA16 MAIN LEVEL control set for the first zone (see above), repeat the above procedure for each of the remaining speaker zones. Be sure to check all microphones in each speaker zone as you proceed.

AUTOMATIC MIXER THRESHOLD ADJUSTMENT

If the sound system (loudspeakers) open unused microphone channels during the adjustment process, increase the turn-on threshold setting on the automatic mixer just enough to keep the unused channels from turning on. This control is labeled THRESHOLD on the Lectrosonics AC1 controller.

SPECIFICATIONS

Audio Input:

Connectors: 3-pin female XLR, electronically balanced and RF filtered
Impedance: 20K Ohms balanced, 10K Ohms unbalanced
Max Input Level: +8dBv

Thru Output:

Connectors: 3-pin male XLR, parallel with Audio Input

Logic Input:

Connectors: Terminal Strip
Impedance: 100K Ohms in parallel with 2.2uF pulled up to +5 volts

Speaker Output:

Connectors: Terminal Strip
Load Impedance: 4 Ohms or greater
Protection: Short circuit
Open circuit
Thermal
Excessively reactive load
THD (20Hz-20KHz): Less than .25% @ 5 watts, 4 Ohms (80KHz filter)
IMD (60Hz/7KHz): Less than .25% @ 5 watts, 4 Ohms (80KHz filter)
Noise (20Hz-20KHz): Less than -75dBv (Gain control at unity)

Line Output:

THD (20Hz-20KHz): Less than .05% @ 4dBv
IMD (60Hz/7KHz): Less than .05% @ 4dBv
Noise (20Hz-20KHz): Less than -90dBv

Attenuation Method:

Automatic Rated-controlled Variable Attenuation*

Power Consumption:

160 Watts maximum

* US PATENT NUMBER 5204908

SERVICE AND REPAIR

If your system malfunctions, you should attempt to correct or isolate the trouble before concluding that the equipment needs repair. Make sure you have followed the setup procedure and operating instructions. Check out the inter-connecting cords and then go through the TROUBLE SHOOTING section in the manual

We strongly recommend that you **do not** try to repair the equipment yourself and **do not** have the local repair shop attempt anything other than the simplest repair. If the repair is more complicated than a broken wire or loose connection, send the unit to the factory for repair and service. Don't attempt to adjust any controls inside the units. Once set at the factory, the various controls and trimmers do not drift with age or vibration and never require readjustment. **There are no adjustments inside that will make a malfunctioning unit start working.**

LECTROSONICS service department is equipped and staffed to quickly repair your equipment. In-warranty repairs are made at no charge in accordance with the terms of the warranty. Out of warranty repairs are charged at a modest flat rate plus parts and shipping. Since it takes almost as much time and effort to determine what is wrong as it does to make the repair, there is a charge for an exact quotation. We will be happy to quote approximate charges by phone for out of warranty repairs.

RETURNING UNITS FOR REPAIR

You will save yourself time and trouble if you will follow the steps below:

- A. DO NOT return equipment to the factory for repair without first contacting us by letter or by phone. We need to know the nature of the problem, the model number and the serial number of the equipment. We also need a phone number where you can be reached 8 am to 4 pm (Mountain Standard Time).
- B. After receiving your request, we will issue you a return authorization number (R.A.). This number will help speed your repair through our receiving and repair departments. The return authorization number must be clearly shown on the outside of the shipping container.
- C. Pack the equipment carefully and ship to us, shipping costs prepaid. If necessary, we can provide you with the proper packing materials. UPS is usually the best way to ship the units. Heavy units should be "double-boxed" for safe transport.
- D. We also strongly recommend that you insure the equipment, since we cannot be responsible for loss of or damage to equipment that you ship. Of course, we insure the equipment when we ship it back to you.

Mailing address:
Lectrosonics, Inc.
PO Box 15900
Rio Rancho, NM 87174
USA

Shipping address:
Lectrosonics, Inc.
581 Laser Rd.
Rio Rancho, NM 87124
USA

Telephones:
(505) 892-4501
(800) 821-1121
FAX: (505) 892-6243

World Wide Web: <http://www.lectrosonics.com>

email: sales@lectrosonics.com

APPENDIX 1 - POWER LOSS vs CABLE RUN

The table below indicates power loss vs cable run for various wire gauges. Nominal output power for the LCA16 is 5 watts at 4 ohms and 3 watts at 8 ohms.

22 AWG Wire, 4 ohm load

<u>Distance</u>	<u>Total Power Available</u>	<u>Load Power</u>	<u>Wire Loss</u>
25ft.	4.8W	4.5W	.3W
50ft.	4.5W	4.0W	.5W
100ft.	4.0W	3.2W	.8W
250ft.	3.1W	1.9W	1.2W

18 AWG Wire, 4 ohm load

<u>Distance</u>	<u>Total Power Available</u>	<u>Load Power</u>	<u>Wire Loss</u>
25ft.	4.9W	4.7W	.2W
50ft.	4.7W	4.3W	.4W
100ft.	4.4W	3.7W	.7W
250ft.	3.6W	2.6W	1.0W

16 AWG Wire, 4 ohm load

<u>Distance</u>	<u>Total Power Available</u>	<u>Load Power</u>	<u>Wire Loss</u>
25ft.	4.9W	4.8W	.1W
50ft.	4.8W	4.6W	.2W
100ft.	4.6W	4.2W	.4W
250ft.	4.0W	3.2W	.8W

22 AWG Wire, 8 ohm load

<u>Distance</u>	<u>Total Power Available</u>	<u>Load Power</u>	<u>Wire Loss</u>
25ft.	2.9W	2.7W	.2W
50ft.	2.7W	2.5W	.2W
100ft.	2.5W	2.1W	.4W
250ft.	2.0W	1.3W	.7W

20 AWG Wire, 8 ohm load

<u>Distance</u>	<u>Total Power Available</u>	<u>Load Power</u>	<u>Wire Loss</u>
25ft.	2.9W	2.8W	.1W
50ft.	2.8W	2.6W	.2W
100ft.	2.7W	2.4W	.2W
250ft.	2.3W	1.7W	.6W

18 AWG Wire, 8 ohm load

<u>Distance</u>	<u>Total Power Available</u>	<u>Load Power</u>	<u>Wire Loss</u>
25ft.	3.0W	2.9W	.1W
50ft.	2.9W	2.8W	.1W
100ft.	2.8W	2.6W	.2W
250ft.	2.5W	2.1W	.4W

16 AWG Wire, 8 ohm load

<u>Distance</u>	<u>Total Power Available</u>	<u>Load Power</u>	<u>Wire Loss</u>
25ft.	3.0W	2.9W	.1W
50ft.	2.9W	2.8W	.1W
100ft.	2.9W	2.7W	.2W
250ft.	2.7W	2.4W	.3W

APPENDIX 2 - LCA16 SYSTEM WORKSHEET

DIPSWITCH SETTINGS

Assigned Mics	SPEAKER															
	1	2	3	4	5	6	7	8	9	10	11	12	13	14	15	16
1																
2																
3																
4																
5																
6																
7																
8																
9																
10																
11																
12																
13																
14																
15																
16																

LIMITED ONE YEAR WARRANTY

The equipment is warranted for one year from date of purchase against defects in materials or workmanship provided it was purchased from an authorized dealer. This warranty does not cover equipment which has been abused or damaged by careless handling or shipping. This warranty does not apply to used or demonstrator equipment.

Should any defect develop, we will, at our option, repair or replace any defective parts without charge for either parts or labor. If we cannot correct the defect in your equipment, we will replace it at no charge with a similar new item. We will pay for the cost of returning your merchandise to you.

This warranty applies only to items returned to us, shipping costs prepaid, within one year from the date of purchase.

This warranty gives you specific legal rights. You may have additional legal rights which vary from state to state.

LECTROSONICS, INC.

**581 LASER ROAD
RIO RANCHO, NM 87124 USA**

July 6, 1999