

# **M187**

## **BELT-PACK TRANSMITTER**

---

---

### **OPERATING INSTRUCTIONS and trouble-shooting guide**

---

---

**LECTROSONICS, INC.**

Rio Rancho, NM

## INTRODUCTION

Thank you for selecting the Lectrosonics M187 transmitter. This transmitter represents over 70 years of combined experience in the design of RF devices and sets new standards for operational convenience, flexibility and mechanical ruggedness. The M187 transmitter features all metal construction and operates on high band frequencies from 150MHz to 216MHz. The M187 was designed primarily for “belt-worn” applications, however it works equally well for other applications and with virtually any mounting configuration.

The M187 uses the microphone cord as the antenna, eliminating an unsightly “dangling wire”. This transmitter may be used with a wide variety of audio sources. The multi-pin input jack allows the use of “phantom powered” lavalier microphones with either positive or negative bias voltages. The M187 will also match low impedance dynamic microphones and high impedance inputs such as musical instruments or tape decks.

Only the M187 transmitter is covered in this manual. Receivers are described in separate manuals. The M187 operates with any Lectrosonics 187 Series VHF receiver. A matched transmitter/receiver combination makes up a wireless “system”.

---

## TABLE OF CONTENTS

INTRODUCTION .....	2
GENERAL TECHNICAL DESCRIPTION .....	3
CONTROLS AND FUNCTIONS .....	4
BATTERY REPLACEMENT .....	6
OPERATING INSTRUCTIONS .....	7
MICROPHONE CORD TERMINATION .....	8
M187 INPUT JACK WIRING .....	9
TROUBLESHOOTING .....	11
SPECIFICATIONS AND FEATURES .....	12
SERVICE AND REPAIR .....	13
RETURNING UNITS FOR REPAIR .....	13
WARRANTY .....	Back cover

*The M187 transmitter is FCC type accepted under the following Parts:  
Part 90 (169-172 MHz) Part 74 (174-216 MHz)*

## GENERAL TECHNICAL DESCRIPTION

The M187 transmitter is comprised of four major functional subsystems: the input compressor, the mic preamp/gain control, the compandor, and the RF transmitter (see block diagram below).

The **mic preamp** is an ultra-low noise type op-amp. Aside from gain control, this stage also adds high frequency pre-emphasis to the audio signal. This insures highest signal-to-noise ratios under varying signal conditions. Gain control is semi-logarithmic to provide smooth gain control action.

The **compandor** is a high quality audio device that processes the input signal such that large dynamic ranges of input signal can be transmitted to the receiver without overload or noise. A complementary system in the receiver recovers the original dynamics of the signal for full audio quality. Compression and expansion ratios are complementary at 2:1. High frequency pre-emphasis is implemented in the transmitter to provide another 10dB signal-to-noise ratio improvement. Matching de-emphasis is provided in all receivers.

The **compressor/limiter** is a low distortion shunt FET compressor. Control signals for the compressor are derived after the compandor to eliminate any possibility of overload under any signal condition up to a maximum of 3 Volts input. The range of limiting action before gross distortion occurs is 35dB.

The compandor in the 187 series transmitters is much tighter than the 185 series. The H187 compandor will hold the transmitter deviation to no more than  $\pm 15\text{kHz}$  under all circumstances. The 185 compandor would allow some excursions beyond 15kHz during strong audio "spikes."

The **RF transmitter** is composed of a crystal stabilized main oscillator followed by a frequency tripler and two frequency doublers. All three stages are double tuned. Double tuning provides high attenuation of spurious signals, which in turn minimizes the possibility that a transmitter would interfere with another transmitter/receiver system on another frequency.

All RF stages are biased from a regulated internal power supply. The output stage has a separate feedback regulator which not only stabilizes its operating point, but also minimizes AM distortion. These regulators keep the RF and audio performance consistent from the beginning (9 Volts) to the end (6.5 Volts) of battery life.

Schematics and alignment instructions will be provided to qualified repair personnel upon request.

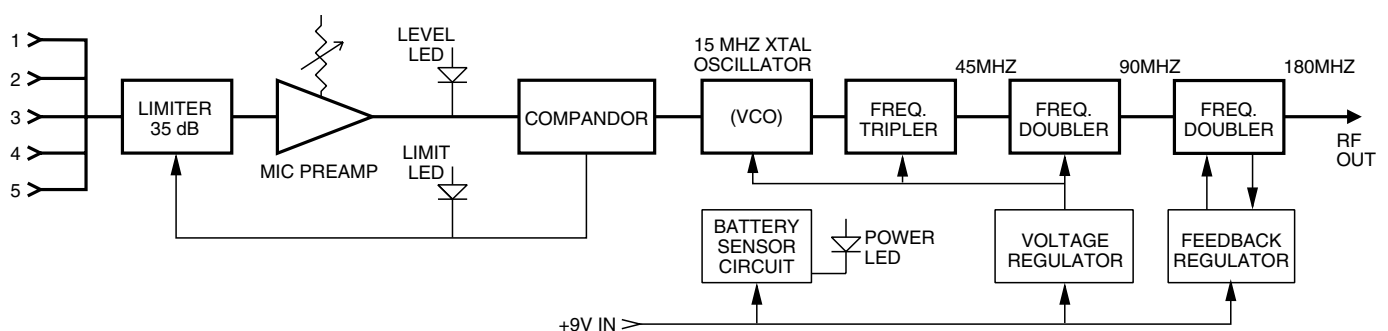

M187 Block Diagram

## CONTROLS AND FUNCTIONS

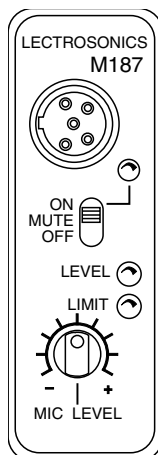

### INPUT JACK

The input on the M187 accommodates virtually every lavalier, hand-held or shotgun microphone available. Use a Switchcraft TA5F connector on the cord. **See the separate sheet titled “M187 Input Jack Configuration” regarding the correct connections for various microphones, and other sources.**

### ON/MUTE/OFF SWITCH

Turns the battery power on and off. The center position is an “audio mute” which should be used when setting the **MIC LEVEL** control to turn off the sound from the microphone during this adjustment. When turning the transmitter on, pause for a moment in the **MUTE** position to prevent a turn-on surge from occurring (a “thump” sound) in the audio.

### POWER ON/OFF LED

Glows brightly when battery is good. A weak or dim lamp means that the battery is weak, and has about an hour of operation left (maybe a little more). If the lamp fails to light, the battery should be replaced. The power lamp should light up in both the “mute” and “on” positions of the POWER/MUTE SWITCH.

The **POWER LED** is connected to a precision battery test circuit that continuously monitors battery voltage. The LED is at full brightness with a new 9 Volt alkaline battery. As the battery voltage drops during use, the LED brightness will also decrease. After 12 to 15 hours the battery voltage will be about 7 Volts and the LED will be completely out.

Since the internal circuits are all tightly regulated and the RF output stage has a separate discrete regulator, the transmitter will continue to operate to a battery voltage of 6.5 Volts. From 6.5 Volts to 6 Volts, the transmitter will still operate, but with degraded performance. Please note that a weak battery will sometimes light the POWER LED immediately after turn on, but will soon discharge to the point where the LED will go out, just like a flashlight with "dead" batteries.

The combination of an accurate battery condition indicator and regulation of all internal circuits provides much longer battery life, as well as consistent performance over the life of the battery.

### **MODULATION LEDES**

Indicate the proper setting of the MIC LEVEL control.

#### **LEVEL LED**

Flickers or glows when sufficient audio is present.

#### **LIMIT LED**

Lights up when the audio volume level is high enough to cause limiting.

#### **MIC LEVEL**

Used to adjust the audio input level for the proper modulation.

### **ANTENNA**

The microphone cord is used as the antenna. A dipole antenna is formed between the shield of the microphone cord and the metal transmitter housing.

### **THE BELT CLIP**

The belt clip may be removed for special applications by removing the two screws.

### **USE ONLY THE SCREWS THAT ARE SUPPLIED**

The circuitry is tightly packed into this unit. Longer screws will permanently damage the transmitter!

## BATTERY REPLACEMENT

The M187 transmitter is powered by a standard alkaline 9 Volt battery. It is important that you use **ONLY** an ALKALINE battery for longest life. Standard zinc-carbon batteries marked “**heavy-duty**” or “**long-lasting**” are not adequate. They will provide only about 4 hours of operation. Similarly, ni-cad rechargeable batteries only provide 4 hours of operation or less, and will also run down quite abruptly. Alkaline batteries provide about 15 hours of operation.

To open the battery compartment, press outward on the cover door in the direction of the arrow as shown in the drawing. Only firm, sliding pressure is needed to open and close the battery door.

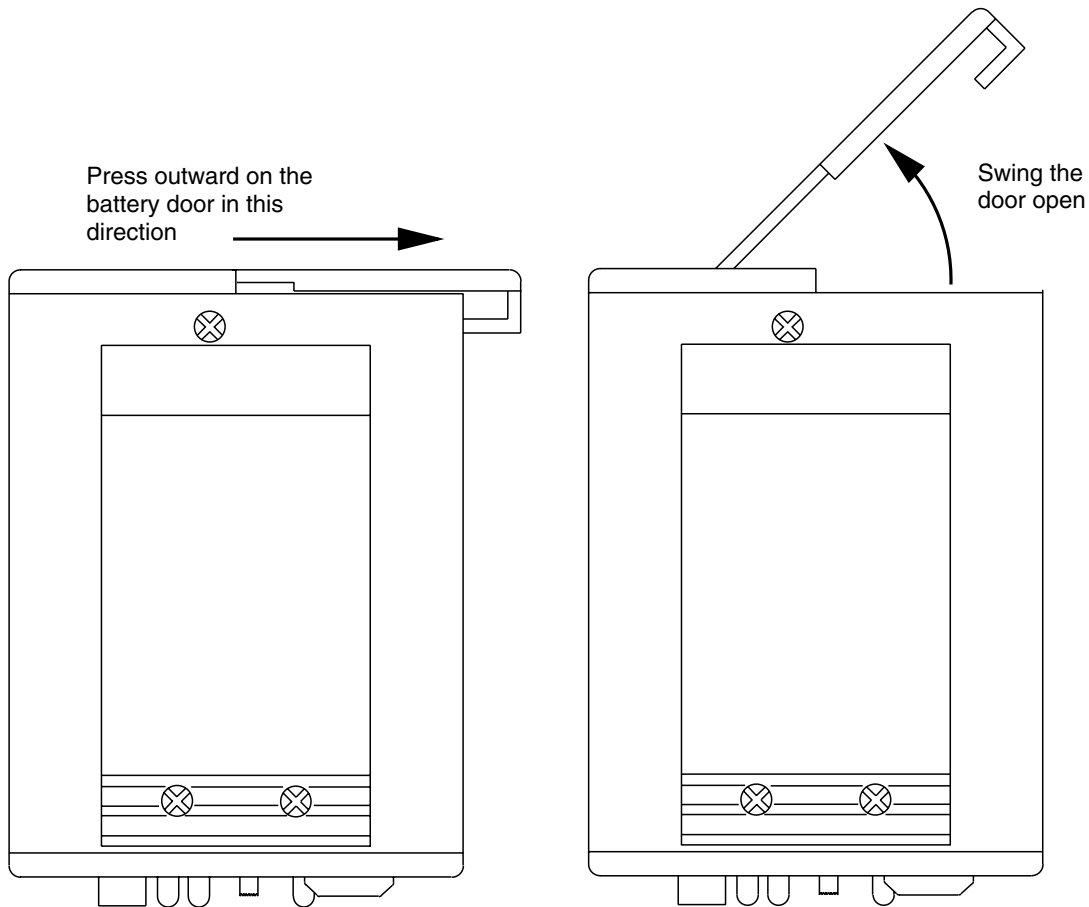

Swing the door open and take note of the polarity marked inside showing the location of the positive (+) and negative (-) terminals. Insert the battery correctly and close the cover by pressing the door closed and across, reversing the opening procedure illustrated above. Don't force the door closed. The terminals will hit a protective polarity barrier. You can see the large and small contact holes inside the battery compartment.

## OPERATING INSTRUCTIONS

- 1) Insert the microphone plug into the input jack, aligning the pins; be sure that the connector locks in.
- 2) Turn the power switch to the “MUTE” position on the transmitter. The “MUTE” position allows internal voltages to stabilize before audio signal paths are opened.
- 3) Position the microphone in the location you will use in actual operation.
- 4) Keeping the power switch in the “mute” position, speak as loudly as you expect you will in normal system use. Rotate the MIC LEVEL knob so that the LEVEL LED flickers or stays lit as you speak. The LIMIT LED should light up on loud “peaks.” Occasional lighting of the LIMIT LED indicates proper operation and optimum signal-to-noise ratio. Even when limiting is occurring, little or no distortion will occur, due to the high linearity of the limiting circuitry in the M187. The input limiter will cleanly handle peaks up to 35dB above full modulation.
- 5) Set up the receiver according to the receiver manual.
- 6) Move the switch to the “ON” position on the transmitter, verify that the modulation LEDs indicate normally and adjust the volume of the sound system, or the record level of your recorder.

**NOTE:**

*Do not use the MIC LEVEL control to control the volume of your sound system or the record level on your recorder. This control should be set only as described in #4 above.*

If the mic level is too high — the LIMIT LED will light frequently or stay on. This condition may cause distortion.

If the mic level is too low — neither LED will light or the LEVEL LED will light dimly. This condition may cause hiss and noise in the audio.

The LEVEL LED turns on at -10dB below full deviation. The LIMIT LED turns on at full deviation and indicates that the input shunt compressor is operating. The input compressor operates over a full 35dB range regardless of the gain control setting. The compressor uses a true absolute value circuit to detect both positive and negative peaks. The attack time is 2 milliseconds and the release time is 80 milliseconds. Occasional limiting is desirable, indicating that the gain is correctly set and the transmitter is being fully modulated.

# MICROPHONE CORD TERMINATION

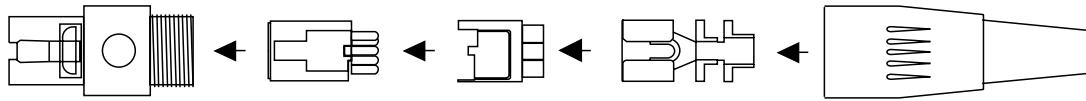

## TA5F Connector Assembly

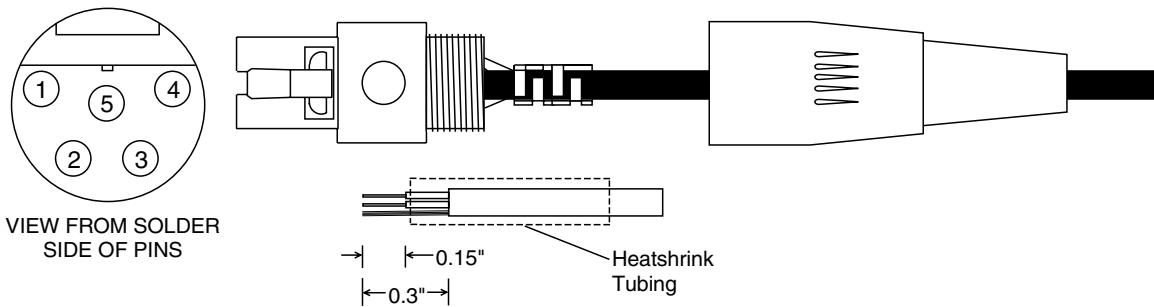

## Mic Cord Stripping Instructions

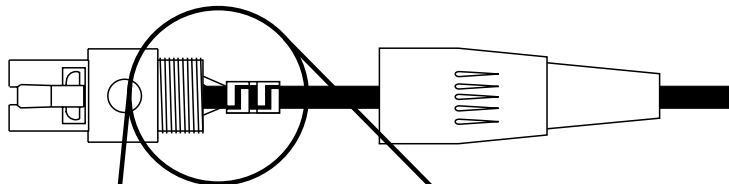

**Caution!**

Do not allow the shield wire to touch any metal part of the connector shell. The shield wire is the antenna on VHF models and poor operating range will result.

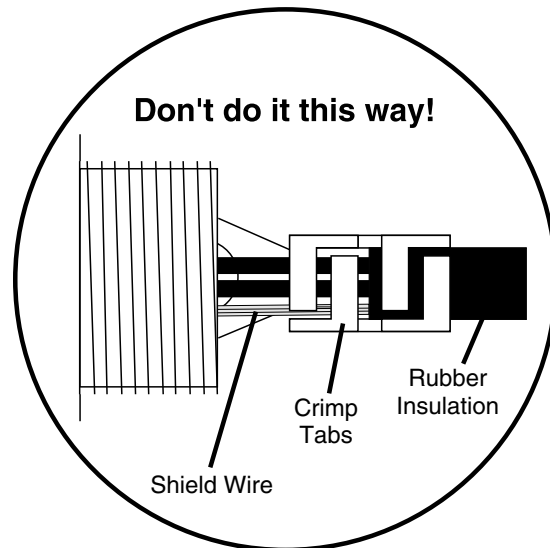
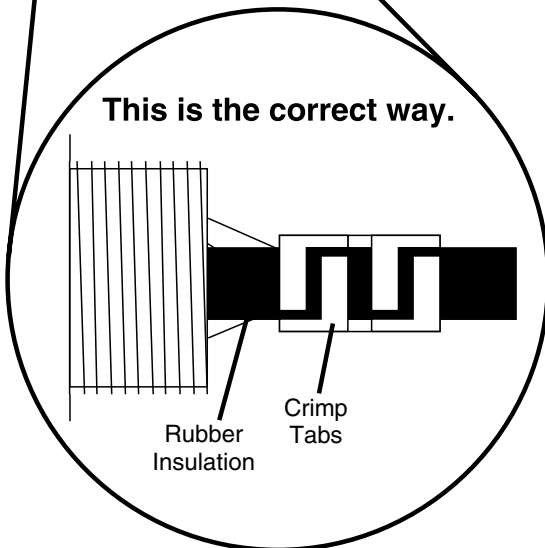

## M187 INPUT JACK WIRING

The wiring diagrams shown on the attached sheet represent the basic wiring necessary for the most common types of microphones and other audio inputs. Some microphones may require extra jumpers or a slight variation on the diagrams shown.

**Caution** - When wiring the connector, do not use the connector body for any electrical connections. A common mistake is to use the connector body as an audio ground. The connector body is already used as an RF ground and no other use is permitted.

It's virtually impossible to keep completely up to date on changes that other manufacturers make to their products. It is possible that you may encounter a microphone that differs from these instructions. If this occurs please call our toll-free number listed in the back of this instruction manual. Our service department can answer your questions regarding microphone compatibility.

When used on a wireless transmitter, the microphone element is in the proximity of the RF coming from the transmitter. The nature of electret microphones makes them sensitive to RF, which can cause problems with the microphone/transmitter compatibility. If the electret microphone is not designed properly for use with wireless transmitters, it will be necessary to install a chip capacitor in the mic capsule or connector to block the RF from entering the electret capsule. These types of modifications are not shown on the attached instructions.

The M187 uses the shield of the microphone cord as the antenna. Other brands use a "dangling wire" to emit the RF from the transmitter. There is really no difference between these two approaches, with respect to the effect of the RF on the microphone capsule. Even in transmitters that utilize a "dangling wire," the microphone is still part of the "ground plane" and is therefore still in the antenna circuit.

For answers to questions regarding microphone/transmitter compatibility, call our service manager or engineering department at the factory.

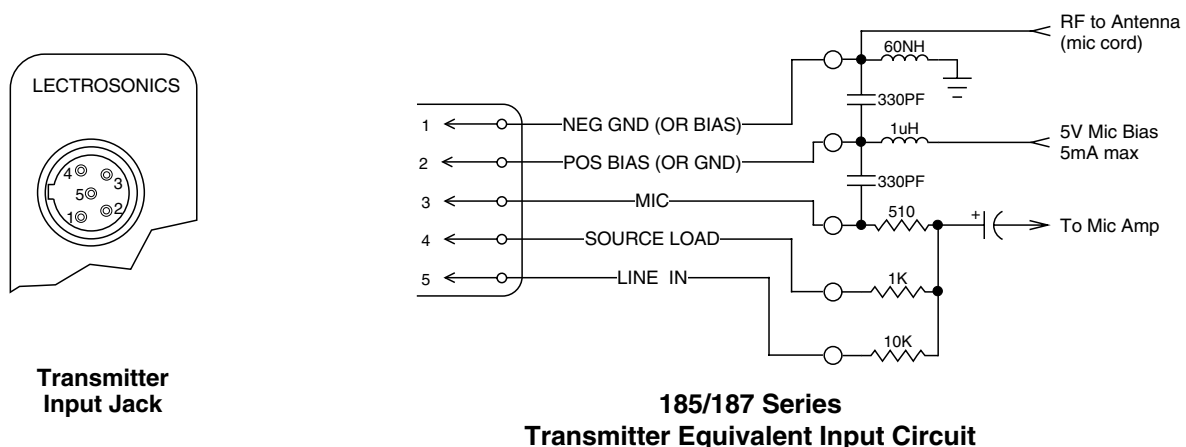

- PIN 1** Shield (ground) for positive biased electret lavalier microphones. Bias voltage source for negative biased electret lavalier microphones. Shield (ground) for dynamic microphones and line inputs.
- PIN 2** Shield (ground) for negative biased electret lavalier microphones. Bias voltage source for positive biased electret lavalier microphones.
- PIN 3** Low impedance microphone level input for dynamic microphones. Also accepts hand-held electret microphones provided the microphone has its own built-in battery.
- PIN 4** 1K ohm source load for non-Lectrosonics electret microphones. Use in conjunction with other pins to provide attenuation of high level input signals.
- PIN 5** High impedance, line level input for tape decks, mixer outputs, musical instruments, etc.

**RF BYPASSING**

Some mics require RF protection to keep the radio signal from affecting the capsule, even though the transmitter input circuitry is already RF bypassed (see schematic diagram).

If the mic is wired as directed, and you are having difficulty with squealing, high noise, or poor frequency response; RF is likely to be the cause.

The best RF protection is accomplished by installing RF bypass capacitors at the mic capsule. If this is not possible, or if you are still having problems, capacitors can be installed on the mic wires inside the TA5F connector housing.

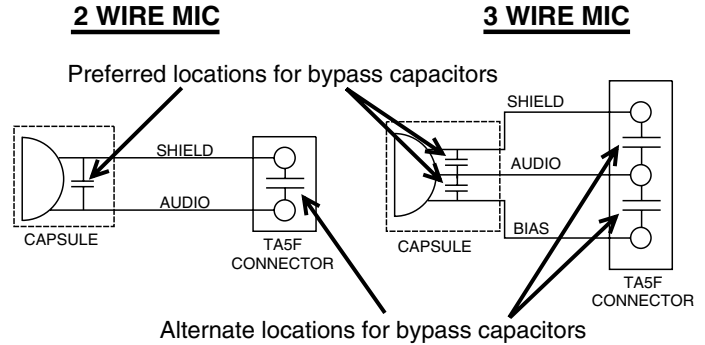

Install the capacitors as follows: Use 330 pF capacitors. Capacitors are available from Lectrosonics. Please specify the part number for the desired lead style.

Leaded capacitors: P/N 15117

Leadless capacitors: P/N SCC330P

All Lectrosonics lavalier mics are already bypassed and do not need any additional capacitors installed for proper operation.

**BODY GROUND**

**Caution** - When wiring the connector, do not use the connector body for any electrical connections. A common mistake is to use the connector body as an audio ground. The connector body is already used as an RF ground on VHF models and no other use is permitted.

**LINE LEVEL SIGNALS**

The normal hookup for line level signals is: Signal Hot to pin 5, Signal Gnd to pin 1, pin 4 jumped to pin 1, and pin 3 jumped to pin 1. This gives a 30dB attenuator that allows signal levels much higher than 3V to be applied without distortion.

If more headroom is needed, insert a 100k resistor in series with pin 5. Put this resistor inside the TA5F connector to minimize noise pickup.

If lower than normal line levels (less than 1V) are expected, use this hookup: Signal Hot to pin 5, Signal Gnd to pin 1, and pin 4 jumpered to pin 1. This provides a 20dB attenuator allowing signals as high as 3V to be applied without distortion.

**WIRING HOOKUPS FOR DIFFERENT SOURCES**

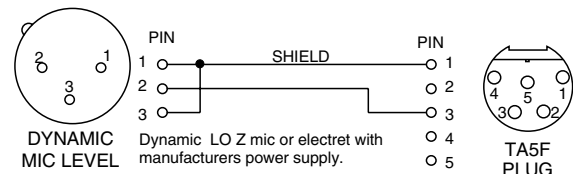
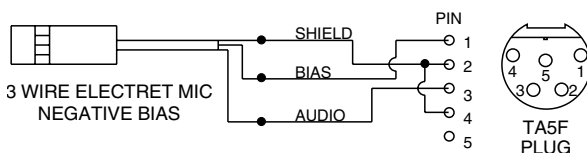
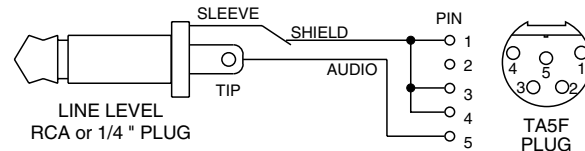
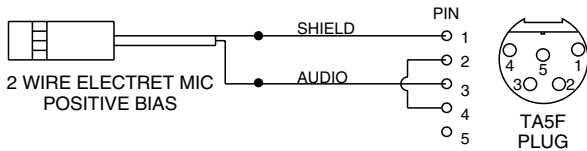
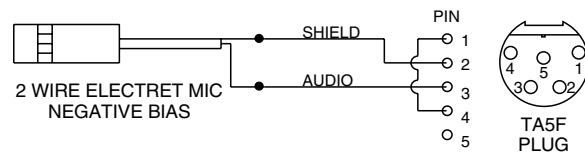
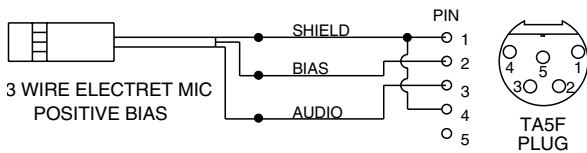

## TROUBLESHOOTING

Before going through the following chart, be sure that you have a good battery in the transmitter the red power LED on the transmitter panel should glow brightly.

SYMPTOM	POSSIBLE CAUSE
<b>TRANSMITTER BATTERY LED OFF</b>	<ol style="list-style-type: none"> <li>1) Battery is inserted backwards.</li> <li>2) Battery is dead.</li> </ol>
<b>NO TRANSMITTER MODULATION LEDS</b>	<ol style="list-style-type: none"> <li>1) Gain control turned all the way down.</li> <li>2) Battery is in backwards. Check power LED.</li> <li>3) Mic capsule is damaged or malfunctioning.</li> </ol>
<b>VERY SHORT OPERATING DISTANCE</b>	<ol style="list-style-type: none"> <li>1) Mic cord not properly terminated. Shield wire may be touching the connector shell. See page 7.</li> </ol>
<b>NO SOUND IS HEARD AND RECEIVER RF LAMP IS OFF</b>	<ol style="list-style-type: none"> <li>1) Transmitter not turned on.</li> <li>2) Transmitter battery is dead.</li> <li>3) Receiver antenna missing or improperly positioned.</li> <li>4) Transmitter and receiver not on same frequency. Check labels on transmitter and receiver.</li> <li>5) Operating range is too great.</li> </ol>
<b>NO AUDIO IS HEARD BUT RECEIVER RF LED IS ON</b>  NOTE: If the modulation level LEDs on the receiver are indicating properly, the problem is NOT in the transmitter.	<ol style="list-style-type: none"> <li>1) On/Off switch is in "mute" position receiver or transmitter.</li> <li>2) Microphone on/off switch is in "off" position.</li> <li>3) Volume is turned down or off on transmitter or receiver.</li> <li>4) Receiver not properly connected to other audio equipment.</li> <li>5) Transmitter POWER switch may be turned on and off (i.e. through the mute position). A "thump" should be heard in the sound, again indicating a properly functioning receiver.</li> </ol>
<b>NO SOUND AND RECEIVER MOD LEVEL LEDS ARE OFF</b>	<ol style="list-style-type: none"> <li>1) Transmitter audio muted. Make sure front panel power switch is in the on position.</li> </ol>
<b>NO SOUND BUT RECEIVER MOD LEVEL LEDS ARE ON</b>	<ol style="list-style-type: none"> <li>1) Receiver audio is muted. Refer to receiver manual.</li> <li>2) Receiver audio output is disconnected or cable is defective or mis-wired.</li> <li>3) Sound system or recorder input is turned down.</li> </ol>
<b>NOISE (HISS) IS HEARD ALONG WITH THE SIGNAL</b>	<ol style="list-style-type: none"> <li>1) MIC LEVEL is too low.</li> <li>2) Transmitter and receiver may be too far from one another.</li> <li>3) Receiver antenna may be defective or disconnected.</li> </ol>
<b>DISTORTED SOUND</b>	<ol style="list-style-type: none"> <li>1) MIC LEVEL is too high.</li> <li>2) Mic may be distorting; try a different mic and listen again.</li> <li>3) PA system may be overloading.</li> </ol>
<b>EXCESSIVE FEEDBACK</b>	<ol style="list-style-type: none"> <li>1) Transmitter gain (audio level) too high. Check gain adjustment and/or reduce receiver output level.</li> <li>2) Microphone too close to speaker system.</li> <li>3) Microphone too far from user's mouth.</li> <li>4) Sound system volume set too high.</li> </ol>

## SPECIFICATIONS AND FEATURES

<b>Operating frequencies:</b>	150 to 216 MHz
<b>RF Power output:</b>	50 mW
<b>Deviation:</b>	±15kHz (max)
<b>Spurious radiation:</b>	55 dB below carrier
<b>Equivalent input noise:</b>	-126 dBV
<b>Input level:</b>	Nominal 2 mV to 300 mV (before compression) 30 Volt max. input level (including limiter)
<b>Input impedance:</b>	Selectable for 500, 1K, 10K Ohm
<b>Input compressor:</b>	Soft compressor, 35dB range
<b>Gain control range:</b>	43 dB; semi-log rotary control
<b>Modulation indicators:</b>	Dual LEDs indicate modulation level and onset of limiting
<b>Controls:</b>	3 position "OFF-MUTE-ON" for noiseless operation Front panel knob adjusts audio gain
<b>Audio Input Jack:</b>	Switchcraft 5 pin locking (TA5F)
<b>Antenna:</b>	Dipole radiator formed by mic cord shield and transmitter housing
<b>Battery:</b>	Precision compartment auto-adjusts to accept any known alkaline 9 Volt battery (We've tried 107 of them!)
<b>Weight:</b>	5.3 ozs. including battery
<b>Dimensions:</b>	3.1 x 2.4 x .75 inches
<b>Emission Designator:</b>	54KOF3E

*Specifications subject to change without notice.*

## SERVICE AND REPAIR

If your system malfunctions, you should attempt to correct or isolate the trouble before concluding that the equipment needs repair. Make sure you have followed the setup procedure and operating instructions. Check out the inter-connecting cords and then go through the TROUBLE SHOOTING section in the manual

We strongly recommend that you **do not** try to repair the equipment yourself and **do not** have the local repair shop attempt anything other than the simplest repair. If the repair is more complicated than a broken wire or loose connection, send the unit to the factory for repair and service. Don't attempt to adjust any controls inside the units. Once set at the factory, the various controls and trimmers do not drift with age or vibration and never require readjustment. **There are no adjustments inside that will make a malfunctioning unit start working.**

LECTROSONICS service department is equipped and staffed to quickly repair your equipment. In-warranty repairs are made at no charge in accordance with the terms of the warranty. Out of warranty repairs are charged at a modest flat rate plus parts and shipping. Since it takes almost as much time and effort to determine what is wrong as it does to make the repair, there is a charge for an exact quotation. We will be happy to quote approximate charges by phone for out of warranty repairs.

## RETURNING UNITS FOR REPAIR

You will save yourself time and trouble if you will follow the steps below:

- A. DO NOT return equipment to the factory for repair without first contacting us by letter or by phone. We need to know the nature of the problem, the model number and the serial number of the equipment. We also need a phone number where you can be reached 8 am to 4 pm (Mountain Standard Time).
- B. After receiving your request, we will issue you a return authorization number (R.A.). This number will help speed your repair through our receiving and repair departments. The return authorization number must be clearly shown on the outside of the shipping container.
- C. Pack the equipment carefully and ship to us, shipping costs prepaid. If necessary, we can provide you with the proper packing materials. UPS is usually the best way to ship the units. Heavy units should be "double-boxed" for safe transport.
- D. We also strongly recommend that you insure the equipment, since we cannot be responsible for loss of or damage to equipment that you ship. Of course, we insure the equipment when we ship it back to you.

Mailing address:

Lectrosonics, Inc.  
PO Box 15900  
Rio Rancho, NM 87174  
USA

Shipping address:

Lectrosonics, Inc.  
581 Laser Rd.  
Rio Rancho, NM 87124  
USA

Telephones:

(505) 892-4501  
(800) 821-1121  
FAX: (505) 892-6243

**World Wide Web:** <http://www.lectrosonics.com>

**email:** [sales@lectrosonics.com](mailto:sales@lectrosonics.com)

## **LIMITED ONE YEAR WARRANTY**

The equipment is warranted for one year from date of purchase against defects in materials or workmanship provided it was purchased from an authorized dealer. This warranty does not cover equipment which has been abused or damaged by careless handling or shipping. This warranty does not apply to used or demonstrator equipment.

Should any defect develop, Lectrosonics, Inc. will, at our option, repair or replace any defective parts without charge for either parts or labor. If Lectrosonics, Inc. cannot correct the defect in your equipment, it will be replaced at no charge with a similar new item. Lectrosonics, Inc. will pay for the cost of returning your equipment to you.

This warranty applies only to items returned to Lectrosonics, Inc. or an authorized dealer, shipping costs prepaid, within one year from the date of purchase.

This Limited Warranty is governed by the laws of the State of New Mexico. It states the entire liability of Lectrosonics Inc. and the entire remedy of the purchaser for any breach of warranty as outlined above. NEITHER LECTROSONICS, INC. NOR ANYONE INVOLVED IN THE PRODUCTION OR DELIVERY OF THE EQUIPMENT SHALL BE LIABLE FOR ANY INDIRECT, SPECIAL, PUNITIVE, CONSEQUENTIAL, OR INCIDENTAL DAMAGES ARISING OUT OF THE USE OR INABILITY TO USE THIS EQUIPMENT EVEN IF LECTROSONICS, INC. HAS BEEN ADVISED OF THE POSSIBILITY OF SUCH DAMAGES. IN NO EVENT SHALL THE LIABILITY OF LECTROSONICS, INC. EXCEED THE PURCHASE PRICE OF ANY DEFECTIVE EQUIPMENT.

This warranty gives you specific legal rights. You may have additional legal rights which vary from state to state.

### **LECTROSONICS, INC.**

---

581 LASER ROAD  
RIO RANCHO, NM 87124 USA

November 1, 2001