

R1a

UHF Multi-Frequency Belt-Pack IFB Receiver



Fill in for your records:

Serial Number:

Purchase Date:

Safety Notes



Excessive sound levels can cause permanent hearing damage.

1. Always adjust the volume to the lowest level before listening to unknown transmissions.
2. Use the lowest reasonable level consistent with hearing safety.
3. Don't use high sound levels in the earphone to overcome high ambient sound levels. That is absolutely foolish! Demand and use high isolation earphones.
4. Don't expose your ears to sound levels that cause them to ring. If your ears do ring after exposure, think of it as a **warning bell** telling you not to do that again.

OSHA (Occupational Safety Health Administration) guidelines on the maximum allowable time exposure to sound pressure levels that will cause hearing damage are as follows:

8 hours	at	90	dB	SPL
4 hours	at	95	dB	SPL
2 hours	at	100	db	SPL
1 hour	at	105	dB	SPL
30 mins	at	110	dB	SPL
15 mins	at	115	dB	SPL

NEVER expose your ears to 120 dB SPL or higher! Damage will occur.

Introduction

Thank you for selecting the Lectrosonics frequency agile, R1a IFB Receiver. The R1a is the result of extensive engineering experience with the very latest components. The design addresses the most demanding professional applications.

The Lectrosonics R1a Receiver along with the companion T1 transmitter allow on-air talent to monitor program audio, and to receive cues from directors and other production personnel.

The R1a Receiver is housed in a rugged, machined aluminum package for lasting performance in abusive environments

Only the R1a IFB Receiver is covered in this manual. The companion T1 transmitter is covered in a separate manual. The R1a IFB Receiver will operate with any Lectrosonics T1 IFB Transmitter in the same frequency block.

Table of Contents

Safety Notes 2

Introduction..... 3

Table of Contents 3

General Technical Description 4

 Features 4

 Control Knob (fig. 1) 4

 LED Indicator (fig. 1) 4

 Headphone Jack (fig. 1 & fig. 2) 5

 Mono Plug/Stereo Plug Usage 5

 Audio Level 5

 Frequency Adjust (fig.3) 5

Receiver Normal Operation 6

 Add a New Frequency to The Next Open Channel 6

 Erase All 5 Channel Memories 7

 Multiple Transmitter Setup 7

Battery Instructions..... 7

Troubleshooting..... 8

Replacement Parts and Accessories..... 9

 Defeating the Frequency & Mode Switch 8

Specifications and Features..... 10

Service and Repair 11

 Returning Units for Repair 11

General Technical Description

The IFBR1 was upgraded to the IFBR1a by adding a number of important and useful features: (1) Two rotary HEX switches to manually set the operating frequency, (2) Automatic sensing/control of a mono phone plug to eliminate the mono/binaural switch, and (3) A multi-color LED for battery status. The Frequency scan and memory features were retained.

Features

The frequency agile IFB R1a FM Receiver is designed to operate with the Lectrosonics IFB T1 Transmitter and features microprocessor control of 256 frequencies of operation within each frequency block. Each block covers 25.6 MHz with 0.1 MHz frequency spacing. Any one of nine different frequency blocks are factory available from 537.6 MHz to 793.5 MHz (except 608 to 614 MHz).

The unique microcontroller design in this receiver provides simple one knob and one LED operation for audio level, switching frequencies (channels), and easy on-the-fly programming. The receiver frequency can be set by manually using the two rotary HEX switches on the side of the unit or by using the automatic scan and store function, or both.

When powered ON, the receiver will default to the frequency set by the switches. A nonvolatile memory can store up to five additional frequencies accessible by pressing the knob. The memory remains during power OFF and even with the battery removed.

The IFB R1a Receiver uses 20 kHz FM deviation for efficient use of the bandwidth and a single band compandor for clean quiet audio.

The Pilot Tone squelch locks the reception to the mating IFB T1 Transmitter and ignores other signals.

The receiver operates on one 9 Volt alkaline battery for up to 8 hours and features a tricolor LED low battery indicator. The voltages are internally regulated for stability.

The receiver is housed in a compact, rugged, light-weight aluminum enclosure. The unit features a durable removable belt clip and an integral rotating battery compartment door.

Control Knob (fig. 1)

The single front panel control knob performs multiple functions;

1. Rotate for Power ON/OFF
2. Rotate for Audio Level
3. Push quick, Channel Switching. (Also see page 9 for special knob setup.)
4. Push and rotate for Scan and Channel programming,

Refer to the RECEIVER OPERATING INSTRUCTIONS for full details on how to use the single knob control for channel selection, scanning, and programming of the five memory locations.



Figure 1 - R1a Control Panel

LED Indicator (fig. 1)

The three color LED indicator on the front panel provides multiple functions.

CHANNEL NUMBER - The LED will blink OFF a number of times corresponding to the Channel Number when the unit is switched ON and also when a new frequency is added to an open channel. For example, for channel 3 the LED would blink OFF three times. After blinking the channel number the LED will return to a steady ON indicating normal operation.

BATTERY STATUS - During normal operation, when the LED is GREEN, the battery is good. When the LED is YELLOW the battery is getting low. When the LED is RED, the battery is nearly depleted and should be replaced.

PROGRAMMING FUNCTIONS - In the programming mode, the LED will blink at a fast rate to indicate scanning for an active frequency. It also flashes briefly to indicate a frequency has been programmed into a channel.



The R1a includes a leather pouch with belt clip to help protect the receiver and provide a way to secure it during use.

Headphone Jack (fig. 1 & fig. 2)

On the front panel is a 3.5mm mini phone jack to accommodate a standard mono or stereo type 3.5 mm plug. The unit will drive low or high impedance earphones. The jack is also the receiver antenna input with the earphone cord acting as the antenna. The cord length is not critical but must be at least 6 inches minimum.

Strain relief to avoid accidental disconnection can be provided with the included small hook and loop strip. Attach the adhesive strip side to the side of the receiver with the opening end of the strip up - place the cord in the strip and secure.



Figure 2 - Headphone cord strain relief

Mono Plug/Stereo Plug Usage

A Mono plug or a Stereo plug can be used with the IFBR1a headphone jack directly. When a Mono plug is inserted, a special circuit senses the “ring” to “sleeve” short and automatically switches off the ring to prevent excess battery drain. To reset, switch power OFF then back ON.

Audio Level

Headphones and ear pieces vary widely in sensitivity and impedance making it impossible to design a receiver with a fixed output power level that is correct for all situations. High impedance phones (600 to 2000) Ohms will have an inherently lower power level due to their high impedance and likewise low impedance phones may be extremely loud. CAUTION! Always set the Audio Level knob to minimum (counter-clockwise) when plugging phones into the jack, then adjust the knob for a comfortable audio level.



Figure 3 - Frequency Adjustment

Frequency Adjust (fig.3)

Two rotary switches adjust the center frequency of the carrier. The 1.6M is a coarse adjustment and the 100K is the fine adjustment. Each transmitter is factory aligned at the center of its operating range. The default position of the frequency select switches is in the center of the transmitter’s range. The receiver and transmitter switches must be set to the same number/letter combination for proper operation.

To gain access to these switches, slide the access door sideways with a fingernail.

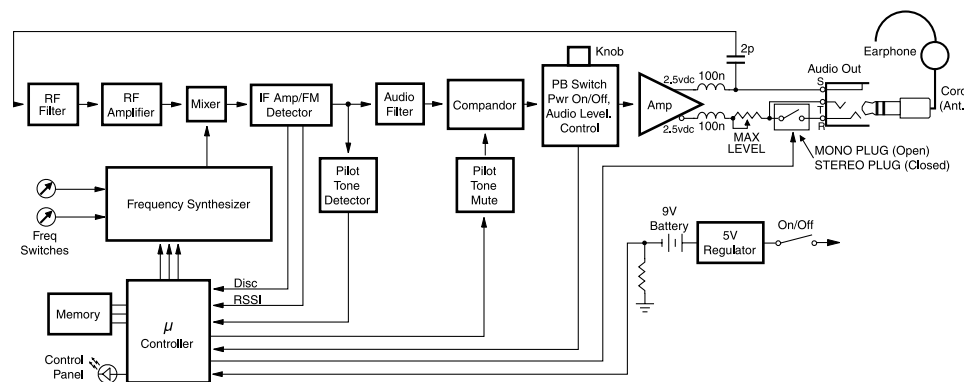

Figure 4 - R1a Block Diagram

Receiver Normal Operation

(already programmed)

1. Set the Frequency of the receiver to match the frequency of the transmitter by using the two HEX rotary switches located on the side of the receiver under the sliding door. The 1.6M switch is for "coarse" adjustment (1.6 MHz per click) and the 100k switch is for "fine" adjustment (0.1 MHz per click). Setting both to zero (00) is the low frequency end of the block and setting both to F (FF) is the highest frequency end of the block.
 2. Plug an earphone or headset into the 3.5mm jack. Be sure the unit has a good battery.
 3. Rotate the knob clockwise to switch the power ON (Do NOT hold the knob in while switching power ON). The LED will illuminate. Rotate the knob to set the desired audio level.
 4. If channel frequencies have been stored in the memory, change channels by pressing the knob briefly and release. The LED will blink the next channel number (frequency) and the receiver will resume operation on that channel. If no channel frequencies have been stored when pressing the knob to change channels, the LED will flash from green to red to yellow to green, indicating no stored channels and the unit will resume operation on the channel set by the switches.
 5. Whenever the power is switched ON, the unit defaults to the frequency set by the switches.
- and the scan/search will resume.
5. To STORE the frequency into a channel memory, depress the knob and hold it until the LED blinks the new channel number, then release the knob. The frequency is now stored in an open channel.
 6. The unit will continue scan/search for other frequencies. To store more frequencies repeat steps 4 and 5 above. Up to 5 frequencies can be stored in memory channels.
 7. When all desired frequencies are stored switch the power to OFF for a few moments, then switch back to ON. The unit will default to the channel number set by the switches and resume normal operating mode.
 8. The first scan is made at low sensitivity and searches for only *high* level transmitter signals to avoid intermods. If the receiver does not stop on any frequency in the first scan, that means an IFB transmitter was not detected. In this condition the LED will change from a fast blink to a slow blink indicating the end of the scan. The complete scan should take 15 to 40 seconds.
 9. A second scan at high sensitivity is initiated by depressing the knob briefly at the end of the first scan to search for low level transmitter signals. When the scan stops and the transmitter audio is heard, either SKIP or STORE the frequency (step 4 or 5 above).
 10. If the receiver still does not stop on any frequency, check that the transmitter is ON. Also, if a frequency is not received or received but distorted, some other signal may be interfering on that frequency. Change the transmitter to another frequency and try again.
 11. Switching the POWER to OFF during any mode simply terminates that mode and returns the unit to normal operating mode when the power is switched back to ON.

Add a New Frequency to The Next Open Channel

Before operating a receiver, one or more IFB T1 transmitters must be placed in XMIT mode, with each transmitter set to the desired frequency and connected to a proper antenna, audio source, and power source. The transmitter frequency block must be the same as the receiver frequency block as marked on each unit.

1. Position the receiver at a location within 20 to 100 feet of the transmitter or transmitters.
2. With the power ON, depress the knob until the LED starts rapidly blinking, then release the knob.
3. The unit goes into program mode and does a scan/search. Previously programmed frequencies will be automatically skipped. When the unit stops on a new frequency audio from the transmitter will be heard in the earphone and the LED will stop blinking rapidly and will change to a slow blink mode.
The unit is now waiting for an operator decision. You must now decide to either SKIP or STORE the frequency (step 4 or 5 below.) Switching the power to OFF without storing will delete the frequency.
4. To SKIP the frequency, depress the knob briefly

Erase All 5 Channel Memories

Note: If knob does not change frequencies or begin scanning when pressed, check to see if its function has been changed - see instructions on page 9.

1. With power OFF, depress the knob and turn the unit ON. Continue to hold the knob down until the LED starts rapidly blinking. The memory is now erased and the unit will go into scan/search mode.
2. Continue from step 3 above - Add New Frequency.

Multiple Transmitter Setup

When using this IFB receiver in a search mode, with two or more transmitters running at the same time, the receiver may stop on a false signal under the following conditions:

- Two transmitters are on and transmitting.
- The distance from the transmitters to the IFB receiver is less than 5 feet.

The false hits are caused by intermodulation or mixing in the front end of the IFB receiver. At a 5 to 10 foot distance, the two carriers are so strong at the receiver, that even this well designed front end will mix the carriers and produce phantom frequencies. The IFB receiver then halts its scan and stops on these false frequencies. All receivers will exhibit this type problem at some transmitter power level and range. You notice false signals more with a scanning mode receiver since it will find them all.

Prevention is simple. Do one of the following:

- Do the scan with only one transmitter on at a time. (Time consuming)
- Increase the receiver to transmitter distance to at least 10 feet. (Preferred)

Battery Instructions

The battery you use in the R1a receiver should be a 9 Volt alkaline or lithium, available almost everywhere. An alkaline battery will provide up to 8 hours of operation and a lithium battery will provide up to 20 hours of operation. Carbon zinc batteries, even if marked "heavy duty" will only provide about 2 hours of operation. Rechargeable batteries will only operate the receiver for an hour or less. Make sure your batteries are marked "**alkaline**" or "**lithium**." Short battery life is almost always caused by weak batteries or batteries of the wrong type.

A green LED corresponds to a fresh battery. The LED will change to yellow for low battery warning then to red to indicate the need for a fresh battery.

To replace the battery, open the bottom battery door cover with your thumb, rotate the door until it is perpendicular with the case and allow the battery to fall out of the compartment into your hand. It is difficult to install the battery backwards. Observe the large and small holes in the battery contact pad before inserting a new battery. Insert the contact end of the battery first, making sure the contacts are aligned with the holes in the contact pad, and then swing the door closed. You will feel it snap into place when it is fully closed.

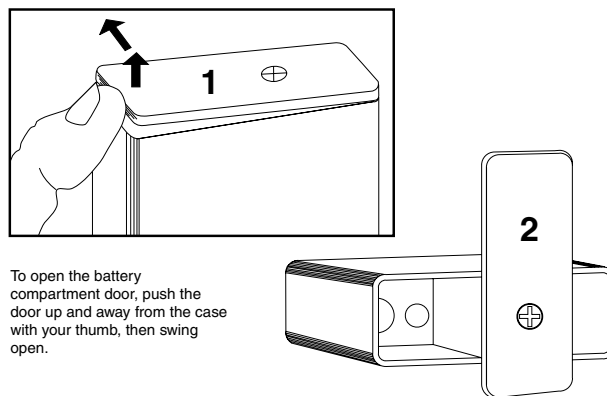

To open the battery compartment door, push the door up and away from the case with your thumb, then swing open.

Figure 5 - Battery Replacement

Troubleshooting

Symptom

Possible Cause

LED NOT LIT

- Battery not installed or depleted
- Power switch not on.

NO SOUND IN HEADPHONE

- AUDIO LEVEL turned all the way down.
- Headphone plug not inserted fully.
- Defective headphone
- Transmitter not operating. (See separate transmitter manual.)
- Receiver not on the same frequency as the transmitter. Refer to "Programming - Add a New Frequency" on page 6.

DISTORTED SOUND

- Transmitter gain (audio level) is far too high. Check mod level lamps on transmitter as it is being used. (Refer to Operating Instructions section in the transmitter manual for details on gain adjustment.)
- Receiver output may be mismatched with the headset or earphone. Adjust Audio Level on receiver to the correct level for the headset or earphone.
- Excessive wind noise or breath "pops." Reposition microphone and/or use a larger windscreen.
- Receiver may be tuned to an intermod. Reprogram the receiver.

HISS AND NOISE, AUDIBLE DROPOUTS

- Transmitter gain (audio level) far too low.
- Receiver antenna missing or obstructed. (Headphone cable is the antenna.)
- Transmitter antenna missing or obstructed.
- Operating range too great.
- Transmitter antenna obstructed
- Receiver antenna (headset cord) may need to be repositioned for a line of sight to transmitter antenna

SHORT RANGE

- Receiver earphone cable is also the antenna. Make sure the cable is not coiled or wound up or wrapped around the receiver case.

KNOB DOES NOT CHANGE FREQUENCIES NOR START SCANNING

- Check to see if the knob function has been changed - see page 9.

Replacement Parts and Accessories

BEZELKITR1A (full kit)

Belt clip, bezel, sliding door, belt clip bumper, mounting screws

Individual Parts:

26377-1	Bezel
25901	Sliding door
IFBR1-M000R	Belt clip assembly
35747	Bumper for belt clip
28528	Belt Clip Screw, 4-40 x 3/16 (1 req'd)
28623	Bezel Screw, 2-56 x 5/16 (2 req'd)

BEZELKITR1A (full kit)



Knob Guard and related parts:

35854	Hex key wrench
28767	Spring washer
26298-1	Knob guard
28443	Spacer washer
26297-1	Knurled knob
28764	Set screws (2 req'd)



Defeating the Frequency & Mode Switch

In some instances, it may be beneficial to alter the knob setup so that the frequency change and mode functions are disabled. A common reason is to prevent the person wearing the receiver from accidentally pushing the button and disrupting the received signal.

Use the following procedure to disable the knob:

- 1) Use the allen wrench to loosen the set screw on the knob.
- 2) Remove knob from shaft.
- 3) Remove spacer washer (Part no. 28443) from hole in knob. Use caution - the washer is small and may fall out.
- 4) Replace knob, making sure to slide the knob all the way onto the shaft.
- 5) Tighten the set screw.

The knob will be prevented from being depressed because it is resting against the knob guard.

Note: If you wish to change the frequency or mode and the knob is unable to be depressed, check to see if this procedure has already been done. You can temporarily enable the functions if you loosen the set screw, pull the knob out a small amount, tighten the set screw, and depress the knob. Then, reverse the procedure to disable the knob again. However, if you wish to permanently enable the knob, replace the spacer washer between the knob and the shaft.

Specifications and Features

Operating frequencies:	537.6 MHz to 608, 614 to 793.5 MHz (in 10 blocks)
Number of frequencies:	256 per block (using 26 MHz wide band)
Channel spacing:	100 kHz
Frequency control:	Crystal Controlled Phase Locked Loop
Sensitivity:	1 uv (20 dB SINAD)
Signal/Noise ratio:	95 dB A-weighted
Squelch quieting:	90 dB
AM rejection:	50 dB, 10 uv to 100 mv
Modulation acceptance:	±20 kHz
Spurious rejection:	Greater than 70 dB
Third order intercept:	0 dBm
Frequency response:	100 Hz to 10 kHz, (±1db)
Pilot tone:	29.997 kHz, 4.5 kHz deviation (fixed crystal controlled)
Audio output, headphone:	1 Vrms into 50 ohms minimum
Antenna:	Headphone cable
Programmable memory:	5 frequencies
Front panel controls:	Single knob controls Audio Output Level, Power on, programming and Scan Frequency Selection
Indicators:	1 tricolor LED Indicator for power on, blinks to indicate channel number, blinks fast during scan, and turns yellow or red for low battery.
Power requirement:	Single 9V Alkaline Battery for approximately 8 hours operation.
Power consumption:	60 ma.
Allen wrench for knob:	0.035" (Lectro part number: 35854)
Weight:	7.3 oz with battery
Size:	3.6 x 2.4 x 0.8 inches

Specifications subject to change without notice.

Service and Repair

If your system malfunctions, you should attempt to correct or isolate the trouble before concluding that the equipment needs repair. Make sure you have followed the setup procedure and operating instructions. Check the interconnecting cables and then go through the **Troubleshooting** section in this manual.

We strongly recommend that you **do not** try to repair the equipment yourself and **do not** have the local repair shop attempt anything other than the simplest repair. If the repair is more complicated than a broken wire or loose connection, send the unit to the factory for repair and service. Don't attempt to adjust any controls inside the units. Once set at the factory, the various controls and trimmers do not drift with age or vibration and never require readjustment. **There are no adjustments inside that will make a malfunctioning unit start working.**

LECTROSONICS' Service Department is equipped and staffed to quickly repair your equipment. In warranty repairs are made at no charge in accordance with the terms of the warranty. Out-of-warranty repairs are charged at a modest flat rate plus parts and shipping. Since it takes almost as much time and effort to determine what is wrong as it does to make the repair, there is a charge for an exact quotation. We will be happy to quote approximate charges by phone for out-of-warranty repairs.

Returning Units for Repair

For timely service, please follow the steps below:

- A. DO NOT return equipment to the factory for repair without first contacting us by letter or by phone. We need to know the nature of the problem, the model number and the serial number of the equipment. We also need a phone number where you can be reached 8 A.M. to 4 P.M. (U.S. Mountain Standard Time).
- B. After receiving your request, we will issue you a return authorization number (R.A.). This number will help speed your repair through our receiving and repair departments. The return authorization number must be clearly shown on the **outside** of the shipping container.
- C. Pack the equipment carefully and ship to us, shipping costs prepaid. If necessary, we can provide you with the proper packing materials. UPS is usually the best way to ship the units. Heavy units should be "double-boxed" for safe transport.
- D. We also strongly recommend that you insure the equipment, since we cannot be responsible for loss of or damage to equipment that you ship. Of course, we insure the equipment when we ship it back to you.

Mailing address:

Lectrosonics, Inc.
PO Box 15900
Rio Rancho, NM 87174
USA

Shipping address:

Lectrosonics, Inc.
581 Laser Rd.
Rio Rancho, NM 87124
USA

Telephone:

(505) 892-4501
(800) 821-1121 Toll-free
(505) 892-6243 Fax

Web:

www.lectrosonics.com

E-mail:

sales@lectrosonics.com

LIMITED ONE YEAR WARRANTY

The equipment is warranted for one year from date of purchase against defects in materials or workmanship provided it was purchased from an authorized dealer. This warranty does not cover equipment which has been abused or damaged by careless handling or shipping. This warranty does not apply to used or demonstrator equipment.

Should any defect develop, Lectrosonics, Inc. will, at our option, repair or replace any defective parts without charge for either parts or labor. If Lectrosonics, Inc. cannot correct the defect in your equipment, it will be replaced at no charge with a similar new item. Lectrosonics, Inc. will pay for the cost of returning your equipment to you.

This warranty applies only to items returned to Lectrosonics, Inc. or an authorized dealer, shipping costs prepaid, within one year from the date of purchase.

This Limited Warranty is governed by the laws of the State of New Mexico. It states the entire liability of Lectrosonics Inc. and the entire remedy of the purchaser for any breach of warranty as outlined above. NEITHER LECTROSONICS, INC. NOR ANYONE INVOLVED IN THE PRODUCTION OR DELIVERY OF THE EQUIPMENT SHALL BE LIABLE FOR ANY INDIRECT, SPECIAL, PUNITIVE, CONSEQUENTIAL, OR INCIDENTAL DAMAGES ARISING OUT OF THE USE OR INABILITY TO USE THIS EQUIPMENT EVEN IF LECTROSONICS, INC. HAS BEEN ADVISED OF THE POSSIBILITY OF SUCH DAMAGES. IN NO EVENT SHALL THE LIABILITY OF LECTROSONICS, INC. EXCEED THE PURCHASE PRICE OF ANY DEFECTIVE EQUIPMENT.

This warranty gives you specific legal rights. You may have additional legal rights which vary from state to state.

