

# R400

## UHF DIVERSITY RECEIVER

(Includes IFB Mode)



Featuring Digital Hybrid Wireless™  
Technology  
(US Patent Pending)

## OPERATING INSTRUCTIONS



Rio Rancho, NM, USA  
[www.lectrosonics.com](http://www.lectrosonics.com)



The Lectrosonics Digital Hybrid Wireless™ (US Patent Pending) uses innovative technology to combine the new advantages of digital audio with the classic advantages of analog RF transmission, thus delivering the superior sound quality of a digital system and the excellent range of an analog system. A proprietary algorithm encodes the digital audio information into an analog format which can be transmitted in a robust manner over an analog FM wireless link. The receiver employs the latest filters, RF amplifiers, mixers and detector to capture the encoded signal and a DSP (Digital Signal Processor) recovers the original digital audio.

This digital/analog hybrid technique has some very beneficial properties. Because the information being transmitted is digitally encoded, immunity to noise is much higher than a compandor can offer. Because the encoded audio is sent in analog format, spectral and power efficiency and operating range are not compromised. Unlike traditional analog compandor systems, no artifacts are introduced under strong RF conditions. Under weak RF conditions, the received signal degrades gracefully, like an analog system, delivering as much usable audio as possible at maximum range. Since the audio is free of compandor artifacts, pumping and breathing problems are also greatly reduced.

## TABLE OF CONTENTS

- GENERAL TECHNICAL DESCRIPTION ..... 4**
  - INTRODUCTION ..... 4
  - DIVERSITY RECEPTION ..... 4
  - RF FRONT-END AND MIXER ..... 4
  - FREQUENCY TUNING GROUPS ..... 4
  - MICROPROCESSOR, PLL AND VCO CIRCUITS ..... 4
  - IF AMPLIFIERS AND SAW FILTERS ..... 5
  - DIGITAL PULSE COUNTING DETECTOR ..... 5
  - DIGITAL SIGNAL PROCESSOR ..... 5
  - COMPATIBILITY MODES ..... 5
  - DSP-BASED PILOT TONE ..... 5
  - SMART SQUELCH™ ..... 5
  - SMART NOISE REDUCTION (SmartNR™) ..... 5
  - LCD SCREEN ..... 6
  - POWER SUPPLY ..... 6
- FRONT PANEL CONTROLS AND FUNCTIONS ..... 7**
  - LCD SCREEN ..... 7
  - POWER/PREV MENU BUTTON ..... 7
- REAR PANEL FEATURES ..... 7**
  - BAL AUDIO OUTPUT JACK ..... 7
  - PUSH FOR MENU/ROTATE TO SELECT CONTROL ..... 7
  - POWER INPUT JACK ..... 7
  - MAIN ANT and DIV ANT ..... 7
- R400 MENU SELECTIONS ..... 8**
  - MENU FUNCTIONS ..... 9
    - SetUpRx ..... 9
    - Freq ..... 9
    - Level ..... 9
    - Tuning ..... 9
    - Compat ..... 9
    - Tone ..... 9
    - PilotBP ..... 9
    - Phase ..... 9
    - TxBatt ..... 10
    - SmartNR ..... 10
    - BACK ..... 10
    - LockSet ..... 10
    - SmrtTun (Firmware version 1.5 and later) ..... 10
    - Scan ..... 10
- ANTENNA USE AND PLACEMENT ..... 12**
- INSTALLATION AND OPERATING INSTRUCTIONS ..... 13**
  - PROGRAMMING USER GROUPS ..... 13
  - ADDING USER GROUP FREQUENCIES ..... 14
  - ERASING USER GROUP FREQUENCIES ..... 14
- R400 REPLACEMENT PARTS AND ACCESSORIES ..... 15**
  - Compatible Frequency Chart ..... 16
- Frequency Coordination ..... 16**
  - Rule No. 1 ..... 16
  - Rule No. 2 ..... 18
  - Rule No. 3 ..... 18
  - Using the Scan Function ..... 18
  - Call Lectrosonics ..... 18
- TROUBLESHOOTING ..... 19**
- SPECIFICATIONS AND FEATURES ..... 21**
- SERVICE AND REPAIR ..... 22**
- RETURNING UNITS FOR REPAIR ..... 22**
- LIMITED ONE YEAR WARRANTY ..... 24**

## GENERAL TECHNICAL DESCRIPTION

### INTRODUCTION

The R400 is a high performance, triple-conversion, frequency synthesized UHF receiver fully compatible with all Lectrosonics 400 Series Digital Hybrid Wireless™ transmitters, 200 and 100 Series analog transmitters, plus analog transmitters from other manufacturers (call Lectrosonics for details). The R400 features 256 user selectable frequencies and its proprietary audio processing includes a digital signal processor (DSP) for very low distortion and a superior signal to noise ratio with audio output adjustable from -50 dBu to +5 dBu in 1 dB increments.

The R400 features a menu-driven LCD graphic display, a pushbutton POWER/PREV MENU control and a dual function (push/rotate) PUSH FOR MENU/ROTATE TO SELECT control (hereafter called the MENU control) as a convenient means of viewing and altering user settings. For example, the Main Window displays the pilot tone indicator, antenna diversity phase, RF level, audio level, operating frequency, transmitter Frequency Select Switch settings and transmitter battery status.

The MENU control provides simple and intuitive access to change and adjust settings and operating levels. Pushing the MENU control from the Main Window enters the Top Menu which displays a choice of four submenu selections: SetUpRx, LockSet, Scan, and Exit. Each subsequent push of the MENU control moves into another menu layer. Rotating the MENU control either selects a submenu or sets a functional parameter.

### DIVERSITY RECEPTION

SMART Diversity™ minimizes dropouts in situations where multi-path reflections can cause serious problems. The phase diversity network and PIN diode RF switches are controlled by the microprocessor using a sophisticated algorithm to use both antennas simultaneously.

### RF FRONT-END AND MIXER

The R400 is frequency agile and can be set to operate on any one of 256 frequencies within its tuning range. To significantly reduce unwanted interference and inter-modulation problems, the R400 has a front-end section that tunes to the desired frequency band and rejects or "tunes out" unwanted out of band signals. Two tuned HI-Q ceramic transmission line resonators prior to a low noise, high current RF amplifier provide good selectivity. A LC bandpass filter after the RF amplifier provides added insurance against strong RF interference. The first mixer uses new GaAs technology that has a very high third order intercept point. The overall design ensures stability, selectivity and precise gain in order to handle strong RF signals without input overload.

### FREQUENCY TUNING GROUPS

The R400 provides four "factory set" compatible frequency groups (A through D) and two user programmable frequency groups (U and V).

The factory groups have been selected to avoid inter-modulation problems. Each group includes eight frequencies.

The user programmable frequency groups can have up to 16 frequencies per group.

### MICROPROCESSOR, PLL AND VCO CIRCUITS

An 8-bit microprocessor monitors user command inputs from the front panel control buttons and numerous other internal signals such as RF level, audio levels, pilot tone levels and external power voltages. The microprocessor also drives the LCD display, controls the squelch and audio output attenuator, and operates the PLL/VCO circuits and the antenna phase switch.

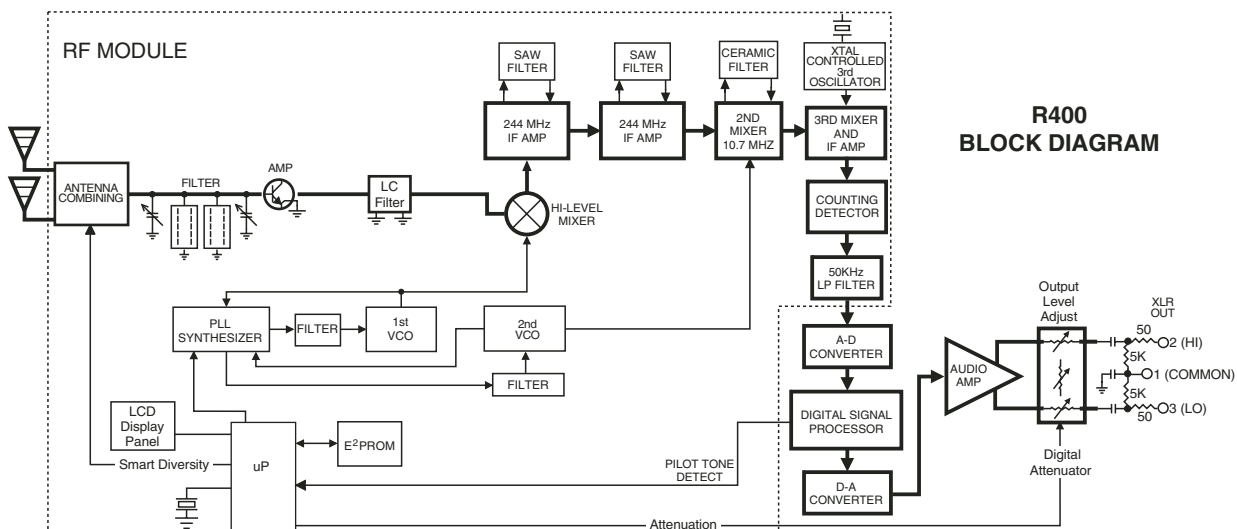

## IF AMPLIFIERS AND SAW FILTERS

The first IF low noise amplifier is controlled with feedback regulation and drives a quartz SAW (Surface Acoustical Wave) filter. The 244 MHz SAW filter combines sharp tuning, constant group delay, wide bandwidth and excellent temperature stability, far superior to conventional LC filters. The second mixer converts the 244 MHz first IF signal down to 10.7 MHz. The second IF is filtered through two ceramic filters for sharp selectivity, then converted down to 300 kHz and fed to the Digital Pulse Counting Detector.

## DIGITAL PULSE COUNTING DETECTOR

The R400 receiver uses an elegantly simple, yet highly effective digital pulse detector to demodulate the FM signal, rather than a conventional quadrature detector. This unusual design eliminates thermal drift, improves AM rejection, and provides very low audio distortion. The output from the Digital Pulse Counter is an analog signal containing the digital audio information. This signal is fed through a low pass filter to an A-D Converter in the Digital Signal Processing section.

## DIGITAL SIGNAL PROCESSOR

The DSP reconstructs the original digitized audio from the A-D Converter and detects the ultrasonic Pilot Tone used to control the receiver's squelch (only in 400 Series and 200 Series Compatibility Mode with the Pilot Tone enabled – see DSP-Based Pilot Tone).

The DSP also incorporates an RF-controlled digital noise filter (in addition to SmartNR™). This RF sensitive variable frequency filter reduces high frequency response under extremely weak RF conditions. The filter does nothing until the RF signal strength drops below 3 uV, at which point it begins to roll off high frequencies. Usable audio remains unaffected, but noise-ups or "hits" occurring near the fringe of reception sound much less harsh.

The reconstructed original analog audio signal is then sent to the audio output section.

## COMPATIBILITY MODES

The R400 receiver was designed to be compatible with Lectrosonics 400 Series transmitters and will yield the best performance when doing so. However, due to the flexibility of digital signal processing, the R400 is also able to operate with Lectrosonics 200 Series, Lectrosonics 100 Series, IFB and certain non-Lectrosonics transmitters in special compatibility modes. (Contact the Lectrosonics Sales Department for a complete list of compatible transmitters.)

## DSP-BASED PILOT TONE

The 400 Series system design uses a DSP generated ultrasonic pilot tone from the transmitter to control the receiver audio muting (squelch). If the Pilot Tone is enabled, a Pilot Tone Detect signal generated by the DSP automatically controls the receiver's squelch. Built-

in brief delays are incorporated to eliminate the thumps, pops or other transients that can occur when the transmitter is turned on or off.

The pilot tone frequency is different for each of the 256 frequencies in the tuning range of a system (frequency block). This eliminates squelch problems in multichannel systems where a pilot tone signal can appear in the wrong receiver via intermodulation products. Using the DSP to detect the pilot tone also eliminates the need for fragile crystals, allowing the receiver to survive shocks and mishandling much better than older analog-based pilot tone systems.

### Note

*The above description applies only in 400 Series mode. In 200 Series mode, only one pilot tone frequency is used on all channels, emulating the original crystal-based system. In other compatibility modes, no pilot tone is used.*

## SMART SQUELCH™

The R400 employs a sophisticated squelching system in an attempt to deliver the cleanest possible audio during marginal conditions of reception. Any squelching system faces inevitable trade-offs: squelch too much and valuable audio information may be lost, squelch too little and excessive noise may be heard; respond too rapidly and the audio sounds "choppy," respond too sluggishly and syllables or entire words can be cut off. The R400 combines several techniques to achieve an optimal balance, removing distracting noise without the squelching action itself becoming a distraction. One of these techniques involves waiting for a word or syllable to complete before squelching. Another incorporates recent squelching history and recent signal strength, adjusting squelching behavior dynamically for the most serviceable result under variable conditions. Using these and other techniques, the R400 can deliver acceptable audio quality from otherwise unusable signals. In the PILOT TONE BYPASS mode, the squelch system is disabled. Received audio remains unmuted at all times with this setting.

## SMART NOISE REDUCTION (SmartNR™)

The wide dynamic range of digital hybrid technology, combined with flat response to 20 kHz, makes it possible to hear the -120 dBV noise floor in the mic preamp, or the (usually) greater noise from the microphone itself. (To put this in perspective, the noise generated by the recommended 4 k Ohm bias resistor of many electret lavalier mics is -119 dBV and the noise level of the microphone's electronics is much higher.) In order to reduce this noise and thus increase the effective dynamic range of the system, the R400 is equipped with a Smart Noise Reduction algorithm, which removes hiss without sacrificing high frequency response.

The Smart Noise Reduction algorithm works by attenuating only those portions of the audio signal that fit a statistical profile for randomness or "electronic hiss." SmartNR™ offers significantly increased transparency over the sophisticated variable low pass filters used in

previous designs. Desired high frequency signals having some coherence such as speech sibilance and tones are not affected.

The Smart Noise Reduction algorithm has three modes, selectable from a user setup screen: Off, Normal and Full.

**OFF** - No noise reduction is performed and complete transparency is preserved. All signals presented to the transmitter's analog front end, including any faint microphone hiss, will be faithfully reproduced at the receiver.

**NORMAL** (factory default) - Enough noise reduction is applied to remove most of the hiss from the mic preamp and some of the hiss from lavalier microphones. The noise reduction benefit is dramatic in this position, yet the degree of transparency maintained is exceptional.

**FULL** - Enough noise reduction is applied to remove most of the hiss from nearly any signal source of reasonable quality, assuming levels are set properly at the transmitter. This additional noise reduction comes at the cost of some transparency for low-level room

noise, yet the algorithm remains undetectable under most circumstances.

*Note*

*The SmartNR setting is user selectable only in 400 Series mode. In other modes, noise reduction is applied in such a way as to emulate the original analog system as accurately as possible and is not user adjustable.*

## **LCD SCREEN**

The LCD screen is used in conjunction with the MENU control to change and control the operational settings, and also provide a visual feedback of overall system operation. (See FRONT PANEL MENU SELECTIONS.)

## **POWER SUPPLY**

The R400 is operated from an external DC power source with a range of +8 VDC to +18 VDC, up to 0.20 amperes (200 milliamps) maximum. The receiver has a built-in Poly-Fuse to protect the unit. If a problem occurs that trips this fuse, it will reset after the power supply is disconnected for about 15 seconds. The power input section also has built-in protection circuits that prevent damage to the receiver if a positive ground power source is applied.

*Note*

*The R400 requires external DC power and has no provisions for internal batteries.*

## FRONT PANEL CONTROLS AND FUNCTIONS



### LCD SCREEN

The LCD Screen is a graphics-type Liquid Crystal Display that is used to monitor system operation and, in conjunction with the MENU control, to configure the R400. (See R400 MENU SELECTIONS.)

### POWER/PREV MENU BUTTON

Dual function control providing a POWER On/Off function and a return to previous menu function. If the receiver is turned off, momentarily pressing this button turns the receiver on. If the receiver is already turned

on, pressing this button causes the LCD to display the previous menu. Pressing and holding the button for at least two seconds turns the unit off.

### PUSH FOR MENU/ROTATE TO SELECT CONTROL

The dual function MENU control is used to access menus and select menu functions or receiver configuration. Push the control to enter the TopMenu, or activate the selected menu option. Rotate the control to either select a submenu or to set an operating parameter.

## REAR PANEL FEATURES



### BAL AUDIO OUTPUT JACK

This is a standard XLR configuration with Pin 2 “positive” with reference to hand-held and plug-on transmitters. With lavalier microphones and belt-pack transmitters, however, phase will vary with different types of microphones (2-wire vs. 3-wire for example). The audio output is balanced but not floating. An unbalanced signal is available using Pin 1 as ground, Pin 2 as signal and leaving Pin 3 open.

### POWER INPUT JACK

The power input jack accepts +8 VDC to +18 VDC (center pin is positive and sleeve is ground). The input is diode protected to prevent damage if the power is applied with reversed polarity, but the unit will not operate until the condition is fixed.

### MAIN ANT and DIV ANT

The MAIN ANT and DIV ANT inputs are both 50 Ohm, BNC connectors. In single antenna configurations, the antenna is connected to the MAIN ANT jack. (See ANTENNA USE AND PLACEMENT.)

# R400 MENU SELECTIONS

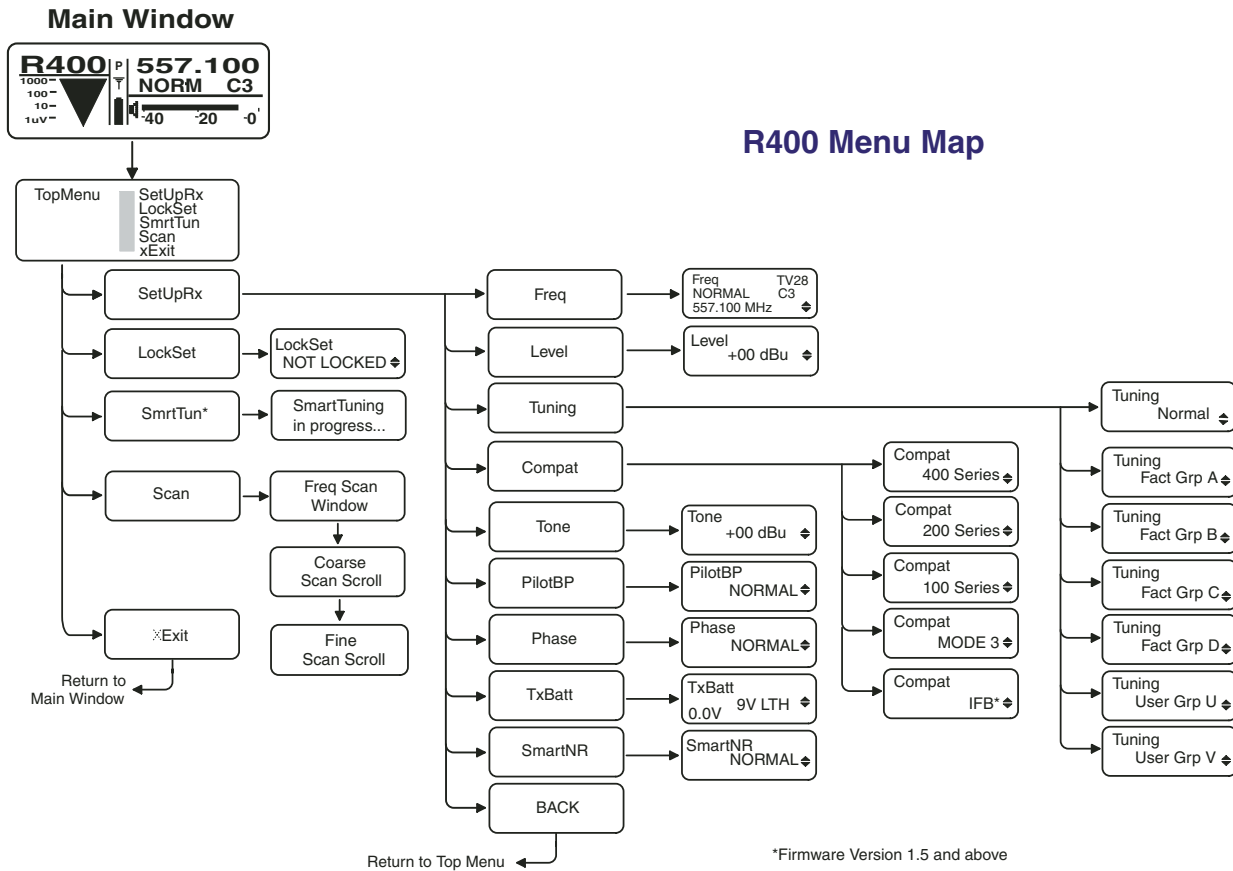

## MAIN WINDOW DISPLAY

Icon	Description
<b>P</b>	<b>Pilot tone indicator</b> - A steady "P" is displayed when the transmitter pilot tone is present (200 Series and the native 400 Series Compatibility Modes only). The icon flashes if no pilot tone is detected and changes to a small "b" if the pilot tone has been bypassed. To bypass the pilot tone, from the Main Window, push the MENU control twice to select SetupRx, then rotate the control to select PilotBP. Push the MENU control again and rotate it to highlight BYPASS. Push the POWER/PREV MENU button several times to return to the Main Window.
	<b>Antenna Phase indicator</b> - Displays antenna phase switching activity. As the DIV ANT phase is switched, the symbol will flip vertically.
	<b>RF level</b> - Displays the relative strength of the incoming RF. The icon grows taller as the strength of the incoming RF signal increases. RF level calibrations are shown from 1 uV to 1000uV on the bezel to the left of the RF level icon.
	<b>Audio Level</b> - The audio level bar changes in size horizontally to indicate the audio level (modulation) of the signal received from the transmitter. The bar display will show a vertical bar at the right end when the audio signal is in limiting (maximum level) at the transmitter. Calibration marks in dB are displayed below the bar.
	<b>Battery Level</b> - Indicates the transmitter battery status or the transmitter battery use time, depending on the TXBAT setting. The transmitter battery status icon is available only in compatibility modes supporting battery telemetry (400 and 200 Series). In such cases, the transmitter battery status icon appears 5 to 10 seconds after the transmitter signal is acquired. If selected in the TXBAT setup screen, the transmitter battery timer is available in any compatibility mode. It accumulates hours and minutes that the communications link is active, retaining the timing even when the receiver is off.
<b>557.100 NORM C3</b>	<b>Operating Frequency/Tuning Mode/Switch Settings</b> - Displays the operating frequency, the tuning mode and the settings for the Frequency Select Switches in the associated transmitter(s). The Tuning Mode indicates whether the receiver is set for Normal tuning or Group tuning. (See Tuning Menu)

The R400 Menu Functions are entered from the Main Window by pressing the MENU control. Navigate from the TopMenu through subsequent submenus and settings by rotating the MENU control to select the desired menu then push it to enter the selected menu.

## MENU FUNCTIONS

The R400 Menu functions can be divided into three main functional areas: setting up the receiver, locking the receiver and scanning for clear frequencies.

### SetUpRx

The SetUpRx menu accesses the menus used to control the operation and compatibility mode of the receiver. These include: Freq, Level, Tuning, Compat, Tone, PilotBP, Phase, TxBatt and SmartNR.

### Freq

The Freq setup screen displays the TV channel (which television broadcast channel this frequency falls within), the associated transmitter Frequency Select Switch settings (C3 in the illustration) and the selected operating frequency. To change the operating frequency, rotate the MENU control. Exit this setup screen by pressing the PREV MENU button. The unit will power up on the frequency last set by the user.

*Note*

*If the operating frequency is changed, ensure that the Frequency Select Switch settings of the associated transmitter match the settings shown in the upper right hand corner of this display.*

### Level

The Level setup screen displays the audio output level of the receiver in dBu. Rotate the MENU control clockwise to increase the level, or counterclockwise to decrease the level. The range is from -50 dBu to +5 dBu in 1 dB increments. Exit this setup screen by pressing the PREV MENU button.

### Tuning

The Tuning setup screen allows selection of one of four factory set frequency groups (Fact Grp A through D) or two user programmable frequency groups (User Grp U and V).

To select group tuning mode, or to return to normal (non-group tuning), navigate through the SetUpRx menu to the Tuning setup screen and press the MENU control. Rotate the MENU control to display the desired factory or user group, then press the PREV MENU button to select that group and return to the SetUpRx screen. (See Installation and Operation, Programming User Groups.)

Use the MENU control to navigate through the SetUpRx menu to Freq, then press the MENU control to enter that setup screen. Rotate the MENU control to the desired operating frequency from the previously selected frequency group. Press the PREV MENU button to select this frequency and return to the Main Window.

The Main Window will display either the current frequency and frequency group or NORM (if no group selected).

### Compat

The Compat setup screen is used to select the compatibility mode, allowing the R400 to operate with a variety of transmitters. The available compatibility modes are:

- 400 - This is the factory default setting and works with all Lectrosonics 400 Series Digital Hybrid Wireless™ transmitters. This mode offers the best audio quality.
- 100 - This mode works with all Lectrosonics 100 Series compatible transmitters.
- 200 - This mode works with all Lectrosonics 200 Series compatible transmitters.
- MODE 3 - This mode works with a number of non-Lectrosonics analog transmitters. Contact the company for a list of compatible transmitters.
- IFB - This mode works with all Lectrosonics IFB compatible transmitters. (Firmware version 1.5 and later.)

### Tone

The Tone setup screen switches from received audio to an internally generated 1 kHz audio test tone at the receiver XLR output for precise level matching with other equipment without actually going "on the air." The level can be adjusted in 1 dB increments by rotating the MENU control. The test tone has 1% distortion and is intended for confirmation of output levels only. Exit this setup screen by pressing the PREV MENU button.

*Warning*

*There is only one audio output level setting for both received audio and the setup tone. The level set here will be retained in the receive mode (superseding settings made in the LEVEL setup screen).*

### PilotBP

The R400 always powers up with the pilot tone bypass mode disabled (a pilot tone is required from the transmitter to unsquelch the receiver). To enable pilot tone bypass mode, in the PilotBP window, rotate the MENU control to select BYPASS, then press the PREV MENU button.

To return to normal operating mode (pilot tone bypass mode disabled), rotate the MENU control to select NORMAL, then press the PREV MENU button. Exit this setup screen by pressing the PREV MENU button.

*Note*

*No Pilot Tone is used in 100 Series or Mode 3 Compatibility Modes, so therefore this function is not offered for those modes.*

### Phase

The default value for receiver audio output is IN PHASE in regard to the audio signal from the transmitter. To invert the receiver's audio output, enter the Phase setup screen, rotate the MENU control to select INVERT. To restore the receiver's audio output to "In Phase," select

**NORMAL** Exit this setup screen by pressing the PREV MENU button.

### TxBatt

The TxBatt setup screen allows the selection of the exact battery type being used in the transmitter to provide more accurate battery level monitoring. Four different types of batteries are commonly used in Lectrosonics transmitters: 9 Volt alkaline, 9 Volt lithium, AA alkaline, and AA lithium. Rechargeable NiMH batteries can also be used in the transmitters (see TIMER below). Correctly set, this feature will ensure that adequate warning will be provided in advance of battery failure.

In 400 Series and 200 Series compatibility modes, the TxBatt menu offers five choices:

**9V ALK** - Transmitter using a 9V alkaline battery. Monitors voltage with battery icon in main window. The relative remaining battery voltage is displayed in the TxBatt setup screen.

**9V LTH** - Transmitter using a 9V lithium battery. Monitors voltage with battery icon in main window. The relative remaining battery voltage is displayed in the TxBatt setup screen.

**AA ALK** - Transmitter using a AA alkaline battery. Monitors voltage with battery icon in main window. The relative remaining battery voltage is displayed in the TxBatt setup screen.

**AA LTH** - Transmitter using a AA lithium battery. Monitors voltage with battery icon in main window. The relative remaining battery voltage is displayed in the TxBatt setup screen.

**TIMER** - Transmitter using any battery, displays time elapsed in the lower left corner of the TxBatt setup screen. The TIMER's colon blinks when the timer is running. When the transmitter or R400 receiver is powered OFF, the timer will retain the last time setting and resume when a signal is detected from the transmitter. To reset the timer, navigate to the TIMER setup screen and quickly press and release the PREV MENU button and the MENU control at the same moment. The TIMER mode is most useful for NiMH batteries as they do not exhibit reliably identifiable voltage drops as they discharge.

For other compatibility modes, no battery telemetry information is available so the TxBatt setup screen offers TIMER as the only choice. Exit this setup screen by pressing the PREV MENU button.

### SmartNR

Available in 400 Series Compatibility Mode only, the Smart NR setup screen is used to select one of three noise reduction modes:

**OFF** - No noise reduction is performed and complete transparency is preserved. All signals presented to the transmitter's analog front end, including any faint microphone hiss, will be faithfully reproduced at the receiver.

**NORMAL** (factory default) - Enough noise reduction is applied to remove most of the hiss from the mic preamp and some of the hiss from lavalier microphones. The noise reduction benefit is dramatic in this position, yet the degree of transparency maintained is exceptional.

**FULL** - Enough noise reduction is applied to remove most of the hiss from nearly any signal source of reasonable quality, assuming levels are set properly at the transmitter.

Rotate the MENU control to select the noise reduction mode. Exit this setup screen by pressing the PREV MENU button.

### BACK

Rotate the MENU control to select BACK, then push the MENU control to return to the TopMenu window.

### LockSet

LockSet is used to lock the R400 settings. When locked, the use of the MENU functions is limited to "view only" and attempts to change selections will result in a screen displaying the word "LOCKED! (To Unlock, Use LockSet Menu)" Also, the unit cannot be used for RF scanning when it is set in the LOCKED state.

To LOCK the R400 - Press the MENU control to enter the TopMenu, then rotate the MENU control to select LockSet. Press the MENU control to open the Lockset window, rotate the MENU control to select LOCK, then push either the MENU control or the PREV MENU button to exit to TopMenu.

To UNLOCK - Repeat the steps above and select NOT LOCKED.

### SmrtTun (Firmware version 1.5 and later)

SmrtTun automates the discovery of a clear operating frequency. It does this by scanning all the available operating frequencies within the systems frequency block range (in 100 KHz increments) and then selecting the frequency with the least amount of RF interference. When SmrtTun is complete, it returns to the Main Window displaying the operating frequency and transmitter switch settings for the clear channel discovered during scanning.

### Scan

To use the integrated scanning function, press the MENU control, rotate it to highlight Scan, and then press the MENU control. The display switches to the Scan Window and automatically starts progressively scanning the selected frequency block. The receiver will continue to scan, adding data with each subsequent scans, until stopped by the user. Data gathered during the scanning process is retained. Scan mode is exited.

To stop scanning (but not exit Scan mode), press the MENU control once. The display switches to the Coarse View window. In this mode, each vertical band of the display represents four frequencies (400 kHz). Rotate

the MENU control to scroll the cursor across the tuning range. As the cursor scrolls across the frequency band, Frequency Select Switch settings for the associated transmitter are shown in the upper right corner of the screen.

Double pressing the MENU control switches the display to Fine View which displays an expanded portion of the spectrum around a fixed, vertical cursor. In Fine View, each vertical band represents one frequency (100 kHz). As with the Coarse View, cursor movement across the frequency band results in the displaying of the associated transmitter Frequency Select Switch settings in the upper right corner of the screen.

In Fine View, the fixed vertical center bar in the center of the view serves as the cursor. Beneath the scan area is a scroll bar to remind you that this is a partial picture of the spectrum. Use the MENU control to scroll through the entire spectrum. Rotate counterclockwise to view

lower frequencies, or clockwise to show higher frequencies.

Scroll through the screen and find a frequency where no RF signals are present (or in the worst case, only very weak RF signals). With the cursor on this frequency, press the PREV MENU buttons to exit from scan mode.

When exiting the scan mode, you are given the option to select either the frequency the unit was on before entering the scan mode, or the frequency just selected in the scan mode. The display shows "Use new freq?" to prompt you to make a frequency selection and also shows the new frequency. Rotate the MENU control to select **Yes**. To return to the frequency you were using before entering the scan mode, MENU control to select **NO**. (The MENU button defaults to NO.) Press PREV MENU to store the selection and exit this menu and return to the TopMenu.

*Note*

*Ensure the transmitter's Frequency Select Switch settings are the same settings as shown on the display and your system will be ready for operation.*

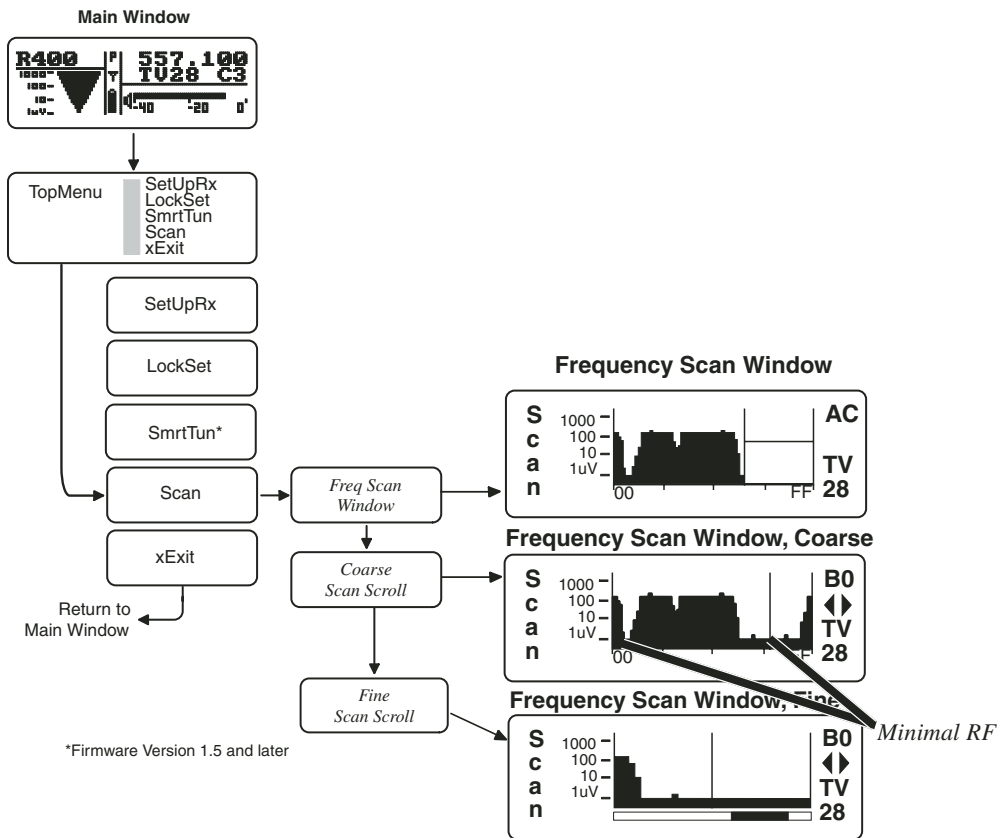

## ANTENNA USE AND PLACEMENT

The receiver is supplied with two right angle BNC antennas. In some circumstances remote antennas such as the SNA600 or ALP700 may be useful for improving reception. Position remote antennas at least three or four feet apart and not within three or four feet of large metal surfaces. If this is not possible, try to position the antennas so that they are as far away from the metal surface as is practical. It is also good to position the receiver so that there is a direct "line of sight" between the transmitter and the receiver antenna. In situations where the operating range is less than about 100 feet, the antenna positioning is much less critical. The antennas can also be configured with one whip mounted directly onto the panel of the receiver, and the other one mounted remotely.

Be careful about the length of cabling from antenna to receiver. Long cable runs can have serious signal loss. Lectrosonics has in-line RF amplifiers suitable for compensating for long cable runs. Contact your dealer or the factory for more information.

A wireless transmitter sends a radio signal out in all directions. This signal will often bounce off nearby walls, ceilings, etc. and a strong reflection can arrive at the receiver antenna along with the direct signal. If the direct and reflected signals are out of phase with each other a cancellation may occur. The result is a "dropout."

A dropout can sound like audible noise (hiss or swishing), or in severe cases, it may result in a complete loss of both the carrier and the sound. Moving the transmitter even a few inches will change the sound of the dropout, or eliminate it. A dropout situation may be either better or worse as a crowd fills and/or leaves the room, or when the transmitter or receiver is operated in a different location.

The receiver offers a sophisticated diversity design which overcomes dropout problems in almost any situation. In the event, however, that you do encounter a dropout problem, first try moving the one of the remote antennas at least three or four feet from its current location. This may alleviate the dropout problem at that location. If dropouts are still a problem, try moving the antennas to an entirely different location.

If the antennas are attached directly to the receiver, try moving the receiver at least three to four feet from its current location. If dropouts are still a problem, try moving the receiver closer to the transmitter.

Lectrosonics transmitters radiate power very efficiently, and the receivers are very sensitive. This reduces dropouts to an insignificant level. If, however, you do encounter dropouts frequently, call the factory or consult your dealer. There is probably a simple solution.

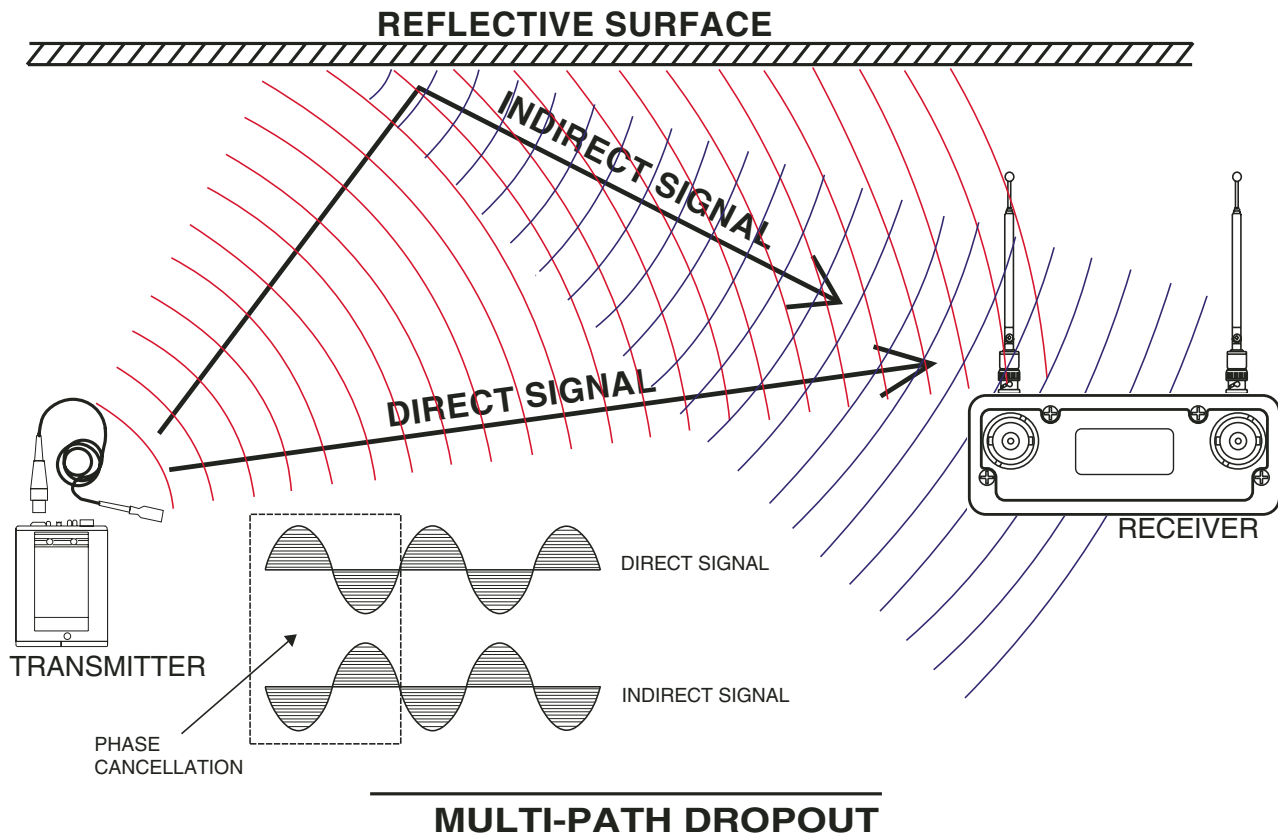

## INSTALLATION AND OPERATING INSTRUCTIONS

1. Connect the power cord from the power supply to the Power Input Jack.



2. Attach the antennas or antenna cables to the MAIN ANT and DIV ANT BNC connectors.
3. Press the POWER/PREV MENU button to turn on the unit on. Check to see that the LCD displays the Power Up Sequence.



This is a sequence of three screens:

Lectrosonics  
 R400 V XX where VXX is the current  
 firmware version installed  
 Block XX where XX is the frequency tuning  
 range block number

After the Power Up Sequence is displayed, the Main Window appears and the R400 is ready for operation.

4. Ensure the receiver and transmitter are set to the same Compatibility Mode, then, for units with Firmware Version 1.5 and later, use SmrtTun™ to locate a clear operating frequency. Otherwise, use the Scan function to locate a clear channel, or manually set the receiver operating frequency via the Freq setup screen. Then set the Transmitter Frequency Select Switches to match the receiver's operating frequency. (See R400 Menu Selections.)

5. Turn the transmitter on and verify that an RF signal is indicated on the LCD.



6. Connect an audio cable to the BAL AUDIO OUT XLR jack.



7. Refer to the associated transmitter operating instructions and adjust the transmitter gain.

**Warning**  
*This is perhaps the most important step in the set up procedure.*

In general, adjust the transmitter gain so that the voice peaks will cause the audio modulation level indicators on both the receiver and transmitter to show full modulation on the loudest peak audio levels.



Normal levels should cause the R400's audio level bar to fluctuate fully resulting in the best possible signal to noise ratio for the system.

*Note*  
 A common mistake is to use the transmitter audio gain control to set the overall audio level of the entire system. The transmitter gain control is not a volume control and must be set independently of the overall system audio level. The transmitter gain control is only used to set the proper modulation of the transmitter. It is used to match the transmitter to the type of microphone and the sound levels that will be present at that microphone. We encourage users to either disconnect the rest of the sound system or turn the sound system gain to minimum to prevent either feedback or overload as the transmitter gain is set. Only after the transmitter gain control is set should the gain of the rest of the audio system be adjusted to achieve the desired sound or signal levels.

8. Use the Level or Tone menus to adjust the audio output level to match the required input level of any connected devices (camera, mixer, recorder, etc.). The adjustment range is from -50 dBu to +5 dBu in 1 dB steps.

*Note*  
 The test tone output is especially useful for an exact level match. With the test tone running, adjust for the maximum desired peak level using the metering on the connected device.

9. If desired, access the LockSet menu to lock the R400 front panel controls to prevent inadvertently modifying the receiver settings during operation.

## PROGRAMMING USER GROUPS

For users who do their own frequency coordination, the R400 offers two user-configurable frequency groups. Up to 16 frequencies can be stored in a user group. Use the following procedure to add or remove frequencies from either user group (User Grp U or User Grp V).

## ADDING USER GROUP FREQUENCIES

1. From the Main Window, press the MENU control to enter SetUpTx, then press the MENU control again to enter the TopMenu and rotate the control to select the Tuning setup screen.
2. Press the MENU control to enter the Tuning setup screen, then rotate the control to select either User Group U or User Group V.
3. Press PREV MENU to return to the SetUpRx menu.
4. Rotate the MENU control to select the Freq menu. Press the control to enter the menu, then double press the control to enter Edit Mode.

### *Note*

*While in Edit Mode, all the frequencies available for use by the receiver will be listed as the MENU control is rotated. Those frequencies already selected for Factory, or User Groups will be identified with a triangle to the left side of the frequency.*

5. Rotate the MENU control to tune to the desired frequency, then simultaneously press the PREV MENU button and the MENU control to store that frequency in the preselected user group. A triangle mark appears to the left of the frequency to indicate that it has been stored.

6. Repeat step 5 for each frequency to be stored in the selected user group.
7. When finished storing user selected frequencies, press PREV MENU to return to the Main Menu.

## ERASING USER GROUP FREQUENCIES

1. From the Main Window, press the MENU control to enter the TopMenu, then press MENU again to enter SetUpRx and rotate the control to select the Tuning setup screen.
2. Press the MENU control to enter the Tuning setup screen, then rotate the control to select either User Group U or User Group V.
3. Press PREV MENU to return to the SetUPRx menu.
4. Rotate the MENU control to select the Freq setup screen. Press the control to enter the menu, then double press the control to enter edit mode.
5. Rotate the MENU control to select the frequency to be erased. (A triangle appears to the left of stored frequencies.) Simultaneously press the PREV MENU button and MENU control to deselect the frequency.

## R400 REPLACEMENT PARTS AND ACCESSORIES

<u>Part No.</u>	<u>Description</u>
<b>DCR12/A4U</b>	AC power supply with US type 2-pin plug on housing, 100 to 240 VAC input; 12 VDC 400 mA regulated output
<b>A500RA</b>	UHF flexible whip antenna with right angle BNC connector (470 - 767 MHz)
<b>SNA600</b>	Collapsible dipole antenna adjustable from 550 MHz to 800 MHz. Ideal for situations where a full 360 degree receiving pattern is required as opposed to a directional pattern.
<b>ALP600</b>	“Shark fin” Log Periodic Dipole Array (LPDA) provides useful directional pattern over 500 to 800 MHz range. Ideal for portable applications including temporary setups for field production. Not intended to be left outdoors permanently.
<b>ALP700A</b>	LPDA (Log Periodic Dipole Array) provides useful directional pattern over a broad frequency bandwidth (500 to 800 MHz).
<b>ARG15-ARG100</b>	Coaxial cables for remote antennas are available from Lectrosionics in a variety of lengths - from 2 to 100 ft. Cables include Velcro tie wraps.
<b>35664</b>	Strip of four adhesive backed feet, 0.75 inches square.

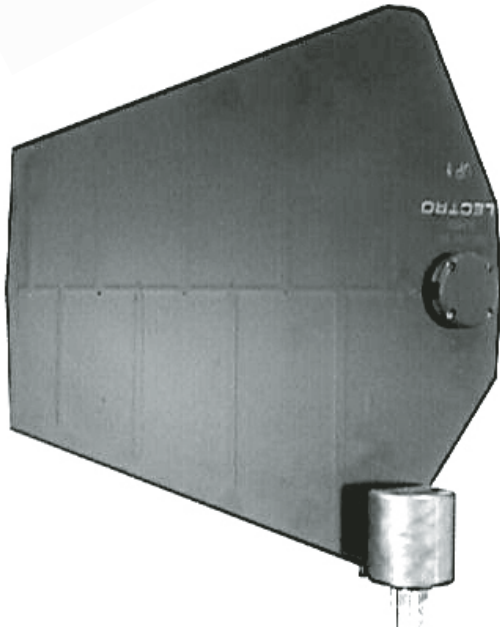

## Frequency Coordination

Intermodulation interference is a problem constantly lurking in the background, especially when working in environments where multiple productions are taking place simultaneously in relative close proximity. In these cases, proper frequency coordination is a must. There are basically three methods coordinate frequencies:

- Use the Compatible Frequency Chart
- Scan for clear channels (See Scan Function)
- Call Lectrosonics

### Compatible Frequency Chart

Considering that multiple systems can be used in a production, coordinating frequencies to minimize interference between these channels can be a daunting process.

The Compatible Frequency Chart was designed to assist in minimizing intermodulation problems for multiple channel wireless systems. It does this by identifying potential intermodulation problems and listing compatible frequencies and frequency groups. This chart can be used with all Digital Hybrid Wireless™ (400 Series) receivers.

The Compatible Frequency Chart divides the frequency blocks used in the North American market into Row 1 and Row 2, then further divides each row into two groups of eight frequencies each. These frequency groups are labeled A and B and C and D, and correspond to the factory set frequency groups (Groups A, B, C and D) described in the Tuning Setup Screen. (See Compatible Frequency Chart.)

Understanding and using the Compatible Frequency Chart is not as difficult as it first appears. There are a few basic rules to follow:

*Note*

*Refer to the Compatibility Frequency Chart's Compatible and Incompatible frequency combinations. (Only frequency blocks 21 and 22 are shown for illustrative purposes.)*

#### Rule No. 1

Row 1 and Row 2 live in two different worlds. The frequencies in Row 1 are not compatible with the frequencies in Row 2. If you are forced to use frequencies from Row 1 with frequencies from Row 2, be aware that intermodulation problems may exist.

### Compatible Frequency Chart

BLOCK 21                      BLOCK 22                      BLOCK 23                      BLOCK 24

ROW 1	Grp A	FREQ	SW SET	US TV CH	FREQ	SW SET	US TV CH	FREQ	SW SET	US TV CH	FREQ	SW SET	US TV CH
		538.100	0,5	tv25	563.700	0,5	tv29	589.300	0,5	tv33	614.900	0,5	tv38
		538.700	0,B	tv25	564.300	0,B	tv29	589.900	0,B	tv33	615.500	0,B	tv38
		539.600	1,4	tv25	565.200	1,4	tv29	590.800	1,4	tv34	616.400	1,4	tv38
		540.200	1,A	tv25	565.800	1,A	tv29	591.400	1,A	tv34	617.000	1,A	tv38
		541.500	2,7	tv25	567.100	2,7	tv30	592.700	2,7	tv34	618.300	2,7	tv38
		542.400	3,0	tv26	568.000	3,0	tv30	593.600	3,0	tv34	619.200	3,0	tv38
		542.900	3,5	tv26	568.500	3,5	tv30	594.100	3,5	tv34	619.700	3,5	tv38
	543.700	3,D	tv26	569.300	3,D	tv30	594.900	3,D	tv34	620.500	3,D	tv39	
	550.100	7,D	tv27	575.700	7,D	tv31	601.300	7,D	tv35	626.900	7,D	tv40	
	552.300	9,3	tv27	577.900	9,3	tv31	603.500	9,3	tv36	629.100	9,3	tv40	
	553.000	9,A	tv27	578.600	9,A	tv32	604.200	9,A	tv36	629.800	9,A	tv40	
	554.300	A,7	tv28	579.900	A,7	tv32	605.500	A,7	tv36	631.100	A,7	tv40	
	556.100	B,9	tv28	581.700	B,9	tv32	607.300	B,9	tv36	632.900	B,9	tv41	
	557.000	C,2	tv28	582.600	C,2	tv32	NOT AVAILABLE			633.800	C,2	tv41	
	559.600	D,C	tv28	585.200	D,C	tv33	NOT AVAILABLE			636.400	D,C	tv41	
	561.900	F,3	tv29	587.500	F,3	tv33	NOT AVAILABLE			638.700	F,3	tv42	

ROW 2	Grp C	FREQ	SW SET	US TV CH	FREQ	SW SET	US TV CH	FREQ	SW SET	US TV CH	FREQ	SW SET	US TV CH
		544.500	4,5	tv26	570.100	4,5	tv30	595.700	4,5	tv34	621.300	4,5	tv39
		545.100	4,B	tv26	570.700	4,B	tv30	596.300	4,B	tv35	621.900	4,B	tv39
		546.000	5,4	tv26	571.600	5,4	tv30	597.200	5,4	tv35	622.800	5,4	tv39
		546.600	5,A	tv26	572.200	5,A	tv31	597.800	5,A	tv35	623.400	5,A	tv39
		547.600	6,4	tv26	573.200	6,4	tv31	598.800	6,4	tv35	624.400	6,4	tv39
		548.800	7,0	tv27	574.400	7,0	tv31	600.000	7,0	tv35	625.600	7,0	tv39
		549.300	7,5	tv27	574.900	7,5	tv31	600.500	7,5	tv35	626.100	7,5	tv40
	549.900	7,B	tv27	575.500	7,B	tv31	601.100	7,B	tv35	626.700	7,B	tv40	
	555.500	B,3	tv28	581.100	B,3	tv32	606.700	B,3	tv36	632.300	B,3	tv41	
	556.500	B,D	tv28	582.100	B,D	tv32	607.700	B,D	tv36	633.300	B,D	tv41	
	557.000	C,2	tv28	582.600	C,2	tv32	NOT AVAILABLE			633.800	C,2	tv41	
	558.700	D,3	tv28	584.300	D,3	tv32	NOT AVAILABLE			635.500	D,3	tv41	
	559.400	D,A	tv28	585.000	D,A	tv33	NOT AVAILABLE			636.200	D,A	tv41	
	560.000	E,0	tv29	585.600	E,0	tv33	NOT AVAILABLE			636.800	E,0	tv41	
	560.700	E,7	tv29	586.300	E,7	tv33	NOT AVAILABLE			637.500	E,7	tv41	
	562.500	F,9	tv29	588.100	F,9	tv33	NOT AVAILABLE			639.300	F,9	tv42	

### Compatible

The following frequency combinations have no intermodulation problems.

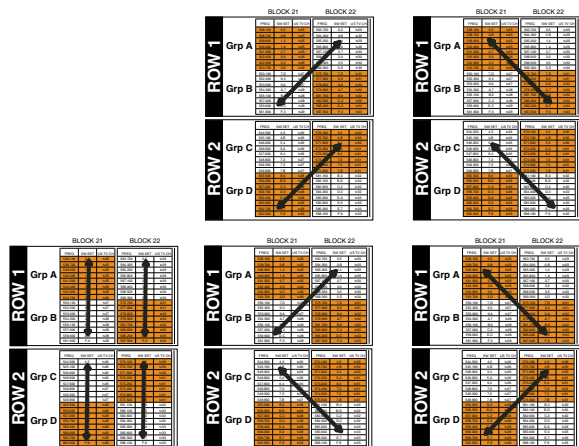

### Incompatible

The following frequency combinations have intermodulation problems and should not be used.

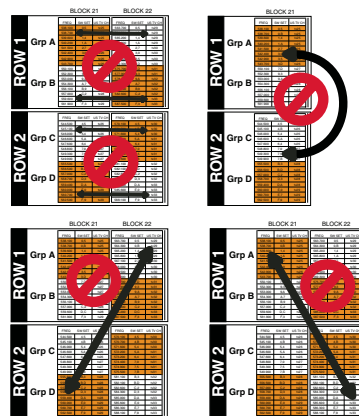

### Compatible Frequency Chart (cont.)

BLOCK 25

BLOCK 26

BLOCK 27

BLOCK 28

BLOCK 29

FREQ	SW SET	US TV CH	FREQ	SW SET	US TV CH	FREQ	SW SET	US TV CH	FREQ	SW SET	US TV CH	FREQ	SW SET	US TV CH
640.500	0,5	tv42	666.100	0,5	tv46	691.700	0,5	tv50	717.300	0,5	tv55	742.900	0,5	tv59
641.100	0,B	tv42	666.700	0,B	tv46	692.300	0,B	tv51	717.900	0,B	tv55	743.500	0,B	tv59
642.000	1,4	tv42	667.600	1,4	tv46	693.200	1,4	tv51	718.800	1,4	tv55	744.400	1,4	tv59
642.600	1,A	tv42	668.200	1,A	tv47	693.800	1,A	tv51	719.400	1,A	tv55	745.000	1,A	tv59
643.900	2,7	tv42	669.500	2,7	tv47	695.100	2,7	tv51	720.700	2,7	tv55	746.300	2,7	tv60
644.800	3,0	tv43	670.400	3,0	tv47	696.000	3,0	tv51	721.600	3,0	tv55	747.200	3,0	tv60
645.300	3,5	tv43	670.900	3,5	tv47	696.500	3,5	tv51	722.100	3,5	tv56	747.700	3,5	tv60
646.100	3,D	tv43	671.700	3,D	tv47	697.300	3,D	tv51	722.900	3,D	tv56	748.500	3,D	tv60
652.500	7,D	tv44	678.100	7,D	tv48	703.700	7,D	tv52	729.300	7,D	tv57	754.900	7,D	tv61
654.700	9,3	tv44	680.300	9,3	tv49	705.900	9,3	tv53	731.500	9,3	tv57	757.100	9,3	tv61
655.400	9,A	tv44	681.000	9,A	tv49	706.600	9,A	tv53	732.200	9,A	tv57	757.800	9,A	tv61
656.700	A,7	tv45	682.300	A,7	tv49	707.900	A,7	tv53	733.500	A,7	tv57	759.100	A,7	tv62
658.500	B,9	tv45	684.100	B,9	tv49	709.700	B,9	tv53	735.300	B,9	tv58	760.900	B,9	tv62
659.400	C,2	tv45	685.000	C,2	tv49	710.600	C,2	tv54	736.200	C,2	tv58	761.800	C,2	tv62
662.000	D,C	tv45/46	687.600	D,C	tv50	713.200	D,C	tv54	738.800	D,C	tv58	764.400	D,C	tv63
664.300	F,3	tv46	689.900	F,3	tv50	715.500	F,3	tv54	741.100	F,3	tv59	766.700	F,3	tv63

FREQ	SW SET	US TV CH	FREQ	SW SET	US TV CH	FREQ	SW SET	US TV CH	FREQ	SW SET	US TV CH	FREQ	SW SET	US TV CH
646.900	4,5	tv43	672.500	4,5	tv47	698.100	4,5	tv52	723.700	4,5	tv56	749.300	4,5	tv60
647.500	4,B	tv43	673.100	4,B	tv47	698.700	4,B	tv52	724.300	4,B	tv56	749.900	4,B	tv60
648.400	5,4	tv43	674.000	5,4	tv47/48	699.600	5,4	tv52	725.200	5,4	tv56	750.800	5,4	tv60
649.000	5,A	tv43	674.600	5,A	tv48	700.200	5,A	tv52	725.800	5,A	tv56	751.400	5,A	tv60
650.000	6,4	tv43/44	675.600	6,4	tv48	701.200	6,4	tv52	726.800	6,4	tv56	752.400	6,4	tv61
651.200	7,0	tv44	676.800	7,0	tv48	702.400	7,0	tv52	728.000	7,0	tv56/57	753.600	7,0	tv61
651.700	7,5	tv44	677.300	7,5	tv48	702.900	7,5	tv52	728.500	7,5	tv57	754.100	7,5	tv61
652.300	7,B	tv44	677.900	7,B	tv48	703.500	7,B	tv52	729.100	7,B	tv57	754.700	7,B	tv61
657.900	B,3	tv45	683.500	B,3	tv49	709.100	B,3	tv53	734.700	B,3	tv58	760.300	B,3	tv62
658.900	B,D	tv45	684.500	B,D	tv49	710.100	B,D	tv54	735.500	B,D	tv58	761.300	B,D	tv62
659.400	C,2	tv45	685.000	C,2	tv49	710.600	C,2	tv54	736.200	C,2	tv58	761.800	C,2	tv62
661.100	D,3	tv45	686.700	D,3	tv50	712.300	D,3	tv54	737.900	D,3	tv58	763.500	D,3	tv62
661.800	D,A	tv45	687.400	D,A	tv50	713.000	D,A	tv54	738.600	D,A	tv58	764.200	D,A	tv63
662.400	E,0	tv46	688.000	E,0	tv50	713.600	E,0	tv54	739.200	E,0	tv58	764.800	E,0	tv63
663.100	E,7	tv46	688.700	E,7	tv50	714.300	E,7	tv54	739.900	E,7	tv58	765.500	E,7	tv63
664.900	F,9	tv46	690.500	F,9	tv50	716.100	F,9	tv55	741.700	F,9	tv59	767.300	F,9	tv63

### Rule No. 2

Frequencies within an individual frequency block in the same row are compatible. For example, all 16 frequencies within Row 1, Block 21 are compatible, and all frequencies in Row 2 Block 21 are compatible. However, frequencies in Row 1, Block 21 are not compatible with the frequencies in Row 2, Block 21. If possible, it is highly recommended to choose frequencies that are in the same row and same group. For example, stick with frequencies in Row 1 Group A, or Row 2 Group D rather than choosing frequencies from Row 1 Groups A and B.

### Rule No. 3

Some frequencies in adjacent blocks are compatible and some are not. Refer to the illustration to the left which shows compatible and incompatible frequency relationships.

By following the three rules, it is possible to locate a number of potential clear operating frequencies early in the production that are intermodulation free, then refine the list during system setup.

### Using the Scan Function

Refer to the Scan section for details on how to use the built-in spectrum scanner.

Interference can result from a wide variety of sources including TV station signals, other wireless equipment in use nearby, or from intermodulation within the Venue system itself. The RF spectrum analyzer built into the R400 system scans the tunable spectrum to find clear channels with little or no interference. After scanning and finding a clear channels, one final procedure is necessary to verify the compatibility of the chosen frequencies.

Turn on the associated transmitter verify there is a strong RF signal. Turn off the transmitter observe the RF level indicator. The RF level should disappear or drop to a very low level. If it does not, change frequency on the receiver and transmitter and try it again.

### Call Lectrosonics

Lectrosonics uses a proprietary computer program to perform thousands of calculations and identify various interfering signals. Potential problems and trouble areas can be identified in advance, and proposed new frequencies or other solutions can be suggested. This service is offered to authorized Lectrosonics dealers and other customers who are using LECTRO™ or Lectrosonics® wireless microphone and wireless IFB systems.

## TROUBLESHOOTING

Symptom	Solution
LCD display not active	External power supply disconnected or inadequate. Main power supply fuse tripped. Turn the receiver off, remove the cause of the overload and turn the receiver back on. Wrong polarity power source. The external DC in requires POSITIVE to be on the center pin.
<b>LCD Message</b>	
<b>Fatal Errors DSP Failed to Initialize</b>	This indicates an internal error. Please contact the factory for assistance.
<b>Warning - Supply Voltage Out of Range</b>	External power supply voltage is too high or too low. Check external power supply.
<b>Warning Check Freq, May Be Mistuned</b>	A strong foreign signal is present on the same operating frequency as the receiver, but it's far enough away from the center of the channel that the audio is likely to be distorted. First, try switching off the transmitter and see if the warning message disappears. If it does, this may indicate a problem with the transmitter. Second, try relocating to unused frequencies. If this doesn't remove the warning message, the transmitter or receiver may need repair.
<b>PILOT indicator is solid "P", but no sound</b>	Audio output cable bad or disconnected. Audio Output level set too low. Use the built-in test tone to verify levels.
<b>PILOT "P" keeps flashing when transmitter power switch is turned on</b>	Pilot tone detection can take several seconds. Turn on the transmitter power (and the audio switch on some models) and wait 3 to 5 seconds for the "P" to indicate steadily. Transmitter and receiver not on same frequency. Receiver compatibility mode does not match the transmitter in use.
<b>Noise on audio and Pilot indicator is "b"</b>	The pilot tone bypass has been activated. Set PilotBP to NORMAL.
<b>Pilot indicator not present but audio is being received</b>	Receiver is set to a compatibility mode that doesn't use pilot tone. Check that receiver compatibility mode matches the transmitter in use as any sufficiently strong signal can unscquelch the receiver in this mode, compatible or not.
	<i>Note</i> <i>In the 400 Series and 200 Series compatibility modes, the PILOT indicator on the front panel shows as a solid "P" to indicate that the audio has been turned on at the transmitter, and that the audio output on the receiver is enabled. When the "P" is on, the audio is enabled. If the "P" is flashing the pilot tone is not detected and the audio will be muted (squelled). In the other compatibility modes, no pilot tone is used and the "P" is never displayed. Audio is present whenever the receiver detects a sufficiently strong signal. In 400 Series and 200 Series compatibility modes, activating the "pilot bypass" function causes a lowercase "b" to appear in the pilot indicator position on the main window and forcibly unscquelches the audio.</i>
<b>RF Level is weak</b>	Receiver may need to be moved or reoriented. Antenna on transmitter may be defective or poorly connected - double check antenna on transmitter. Improper length of antenna, or wrong antenna on transmitter or receiver. UHF whip antennas are generally about 3 to 5 inches long. UHF helical antennas may be shorter, but are often less efficient.

Symptom	Solution
<b>No RF Signal</b>	Make certain frequency switches on transmitter match the receiver frequency setting. Check battery in transmitter.
<b>Poor signal to noise ratio</b>	Transmitter gain set too low. The noise may not be in the wireless system. Turn the transmitter audio gain all the way down and see if the noise remains. If the noise remains, then turn the power off at the transmitter and see if it remains. If the noise is still present, then the problem is not in the transmitter. If noise is still present when the transmitter is turned off, try lowering the audio output level on the R400 and see if the noise lowers correspondingly. If the noise remains, the problem is not in the receiver. Receiver output is too low for the input of the device it is feeding. Try increasing the output level of the R400 and lowering the input gain on the device the R400 is feeding.
<b>Distortion</b>	Transmitter input gain too high. Check and/or readjust input gain on transmitter according to the LEDs on the transmitter and then verify the setting with the audio meter in the main window. Audio output level too high for the device the R400 is feeding. Lower the output level of the R400.
<b>Bad frequency response or generally poor audio quality</b>	Ensure the receiver is set to the compatibility mode that matches the transmitter in use.

*Note*

*A number of symptoms may be caused by a strong interfering signal on the same frequency. Use the R400 Scan function to verify the transmitter and receiver are operating on a clear frequency channel.*

# SPECIFICATIONS AND FEATURES

**Operating Frequencies (MHz):** Block 21: 537.600 - 563.100  
 Block 22: 563.200 - 588.700  
 Block 23: 588.800 - 607.900 and 614.100 - 614.300  
 Block 24: 614.400 - 639.900  
 Block 25: 640.000 - 665.500  
 Block 26: 665.600 - 691.100  
 Block 27: 691.200 - 716.700  
 Block 28: 716.800 - 742.300  
 Block 29: 742.400 - 767.900  
 Block 944:944.100 - 951.900

**Frequency Adjustment Range:** 25.5 MHz in 100 kHz steps

**Receiver Type:** Triple conversion, superheterodyne, 244 MHz , 10.7 MHz and 300 kHz

**Frequency Stability:** ±0.001 %

**Front end bandwidth:** ±30 MHz @ -3 dB

**Sensitivity**

20 dB Sinad: 1 uV (-107 dBm), A weighted

60 dB Quieting: 1.5 uV (-104 dBm), A weighted

**Squelch quieting:** Greater than 100 dB

**AM rejection:** Greater than 60 dB, 2 uV to 1 Volt (Undetectable after processing)

**Modulation acceptance:** 85 kHz

**Image and spurious rejection:** 85 dB

**Third order intercept:** 0 dBm

**Diversity method:** Phased antenna combining - SmartDiversity™

**FM Detector:** Digital Pulse Counting Detector operating at 300 kHz

**Antenna inputs:** Dual BNC female, 50 Ohm impedance

**Audio outputs** Rear Panel XLR adjustable from -50 dBu to +5 dBu in 1 dB steps. Calibrated into a typical 10 k Ohm balanced load. Can drive 600 Ohm load.

## FRONT PANEL CONTROLS AND INDICATORS

**PUSH FOR MENU/ROTATE TO SELECT control:** Push knob for menu selection and rotate for settings.

**POWER/ PREV MENU button:** Momentary press for power ON.  
 Press and hold several seconds for POWER OFF.  
 Momentary press (if unit is powered up) for return to previous window

**LCD Main window:** Pilot tone; antenna phase, transmitter battery status; audio level, RF level; Battery timer; Frequency; and Transmitter switch setting

**Audio output level adjustment:** -50 dBu to +5 dBu

**Battery level tracking:** Receiver and transmitter (9 V battery) in 1/10th volt steps, accuracy +/- 0.2 V. Transmitter (AA battery), accuracy +/- 0.05 V. Timer option available.

**Scanning mode:** Coarse and fine modes for RF spectrum site scanning

**Audio test tone:** 1 kHz, -50 dBu to +5 dBu output, < 1% THD

**Transmitter battery type selection:** 9 V alkaline, 9 V lithium, AA alkaline, AA lithium, TIMER

**Phase invert:** Audio output phase normal or inverted

**Smart NR (noise reduction):** OFF, NORMAL, FULL modes (avail in 400 Series mode only)

**Audio Performance (overall system):**  
*(These specs apply to 400 Series mode only.)*

**Frequency Response (Typ.):** 70 Hz to 20 kHz (+/- 1 dB), 40 Hz to 20 KHz (+/- 3 dB) when used with the LM transmitter. System frequency response will vary depending on transmitter used

**THD:** 0.2% (typical)

**SNR at receiver output (dB):**

SmartNR	No Limiting	W/ Limiting
OFF	103.5	108.0
NORMAL	107.0	111.5
FULL	108.5	113.0

**Input Dynamic Range:** 125 dB (with full Tx limiting)

**Rear Panel Controls and features:** XLR audio output jack; External DC input; BNC antenna connectors.

**Power, Ext DC:** Minimum 8 volts to maximum 18 volts DC; 1.6 W, 200 mA maximum.

**Weight:** 13 oz.

**Dimensions:** 5.50" (14 cm) wide, 1.75" (4.5 cm) high, 6.25" (16 cm) deep

*Specifications subject to change without notice*

## SERVICE AND REPAIR

If your system malfunctions, you should attempt to correct or isolate the trouble before concluding that the equipment needs repair. Make sure you have followed the setup procedure and operating instructions. Check out the interconnecting cords and then go through the TROUBLESHOOTING section in the manual.

We strongly recommend that you **do not** try to repair the equipment yourself and **do not** have the local repair shop attempt anything other than the simplest repair. If the repair is more complicated than a broken wire or loose connection, send the unit to the factory for repair and service. Don't attempt to adjust any controls inside the units. Once set at the factory, the various controls and trimmers do not drift with age or vibration and never require readjustment. **There are no adjustments inside that will make a malfunctioning unit start working.**

LECTROSONICS' Service Department is equipped and staffed to quickly repair your equipment. In warranty repairs are made at no charge in accordance with the terms of the warranty. Out-of-warranty repairs are charged at a modest flat rate plus parts and shipping. Since it takes almost as much time and effort to determine what is wrong as it does to make the repair, there is a charge for an exact quotation. We will be happy to quote approximate charges by phone for out-of-warranty repairs.

## RETURNING UNITS FOR REPAIR

You will save yourself time and trouble if you will follow the steps below:

- A.** DO NOT return equipment to the factory for repair without first contacting us by letter or by phone. We need to know the nature of the problem, the model number and the serial number of the equipment. We also need a phone number where you can be reached 8 am to 4 pm (Mountain Standard Time).
- B.** After receiving your request, we will issue you a return authorization number (R.A.). This number will help speed your repair through our receiving and repair departments. The return authorization number must be clearly shown on the outside of the shipping container.
- C.** Pack the equipment carefully and ship to us, shipping costs prepaid. If necessary, we can provide you with the proper packing materials. UPS is usually the best way to ship the units. Heavy units should be "double-boxed" for safe transport.
- D.** We also strongly recommend that you insure the equipment, since we cannot be responsible for loss of or damage to equipment that you ship. Of course, we insure the equipment when we ship it back to you.

### Mailing address:

Lectrosonics, Inc.  
PO Box 15900  
Rio Rancho, NM 87174  
USA

### Shipping address:

Lectrosonics, Inc.  
581 Laser Rd.  
Rio Rancho, NM 87124  
USA

### Telephones:

Regular: (505) 892-4501  
Toll Free (800) 821-1121  
FAX: (505) 892-6243

**Web:** <http://www.lectrosonics.com>

**Email:** [sales@lectrosonics.com](mailto:sales@lectrosonics.com)



## LIMITED ONE YEAR WARRANTY

The equipment is warranted for one year from date of purchase against defects in materials or workmanship provided it was purchased from an authorized dealer. This warranty does not cover equipment which has been abused or damaged by careless handling or shipping. This warranty does not apply to used or demonstrator equipment.

Should any defect develop, Lectrosonics, Inc. will, at our option, repair or replace any defective parts without charge for either parts or labor. If Lectrosonics, Inc. cannot correct the defect in your equipment, it will be replaced at no charge with a similar new item. Lectrosonics, Inc. will pay for the cost of returning your equipment to you.

This warranty applies only to items returned to Lectrosonics, Inc. or an authorized dealer, shipping costs prepaid, within one year from the date of purchase.

This Limited Warranty is governed by the laws of the State of New Mexico. It states the entire liability of Lectrosonics Inc. and the entire remedy of the purchaser for any breach of warranty as outlined above. NEITHER LECTROSONICS, INC. NOR ANYONE INVOLVED IN THE PRODUCTION OR DELIVERY OF THE EQUIPMENT SHALL BE LIABLE FOR ANY INDIRECT, SPECIAL, PUNITIVE, CONSEQUENTIAL, OR INCIDENTAL DAMAGES ARISING OUT OF THE USE OR INABILITY TO USE THIS EQUIPMENT EVEN IF LECTROSONICS, INC. HAS BEEN ADVISED OF THE POSSIBILITY OF SUCH DAMAGES. IN NO EVENT SHALL THE LIABILITY OF LECTROSONICS, INC. EXCEED THE PURCHASE PRICE OF ANY DEFECTIVE EQUIPMENT.

This warranty gives you specific legal rights. You may have additional legal rights which vary from state to state.