

UCR200D

DIVERSITY UHF RECEIVER

OPERATING INSTRUCTIONS

and trouble-shooting guide

LECTROSONICS, INC.

Rio Rancho, NM

Table of Contents

GENERAL TECHNICAL DESCRIPTION	3
GENERAL TECHNICAL DESCRIPTION	4
GENERAL TECHNICAL DESCRIPTION	5
FRONT PANEL CONTROLS AND FUNCTIONS	6
REAR PANEL CONTROLS AND FUNCTIONS	7
ANTENNA USE AND PLACEMENT	8
INSTALLATION AND OPERATING INSTRUCTIONS	9
UCR200D REPLACEMENT PARTS and ACCESSORIES	9
FREQUENCY BLOCKS AND RANGES	10
TROUBLESHOOTING	11
SERVICE AND REPAIR	12
RETURNING UNITS FOR REPAIR	12
SPECIFICATIONS AND FEATURES	13
WARRANTY	Back cover

GENERAL TECHNICAL DESCRIPTION

The UCR200D is a portable, high performance, dual-conversion, frequency synthesized, UHF receiver. The RF performance is extremely stable over a very wide temperature range, making the UCR200D perfectly suited to the rough environmental conditions found in the field. The proprietary audio processing includes a dual-band compandor for very low distortion and a superior signal to noise ratio. The squelch system is operated by a separate pilot tone and mutes the audio output directly at the output connector. The audio output is calibrated for exact level matching, with a ten LED bar graph meter.

DIVERSITY RECEPTION

The antenna phase switching diversity technique was chosen in order to keep the receiver compact enough for camera mounted or shoulder bag applications. This diversity reception technique effectively minimizes dropouts in short range situations where multi-path reflections can cause serious problems. The optimum diversity reception is realized with the diversity antenna placed away from the receiver, however, dropouts are significantly reduced with two antennas mounted directly on the receiver.

RF SECTION

The problem posed to the design staff was to retain the RF reliability of the Lectrosionics' fixed frequency designs but add the flexibility of a frequency agile design. The universal (and poor) way to build frequency agile systems is to design a wide open front end that will pass any frequency within the tuning range of the system. This leads to very poor RF performance with lots of interference, driving the user to switch frequencies in an attempt to sidestep the interference. This makes frequency agile receivers a self fulfilling system; you have to use the frequency agility to get away from the problems caused by the frequency agile design compromises.

The problem of frequency agility is further compounded when you realize that frequency changes "on the fly" cannot be made on any type of wireless system. For example, if there is suddenly an interference problem with a system in use, on stage for instance, a frequency change cannot be made without interrupting the program. Basically, the show must go on. In multi-channel applications, changing the frequency of one system will usually produce all kinds of new intermodulation problems with the other systems operating in the same location. Frequency agility is not the universal panacea for interference problems. It is only another

tool and a limited tool at that. The first line of defense must be the system's basic immunity to interference. That required a new look at frequency agile receiver design.

FREQUENCY TRACKING FRONT-END

Our solution to the wide open front end problem was to design a selective front end that can be tuned to the frequency in use. Since we wanted this front end to be equivalent to our fixed frequency front ends, this was a daunting task. Lectrosionics has always used front ends with more sections and much more selectivity than any other wireless manufacturer. The final design consisted of a total of 6 transmission line resonators with variable capacitance applied to each resonator by the hexadecimal switches. This allows each resonator to be individually tuned by the hexadecimal switches for any user selected frequency in a 25 MHz band.

This sophistication produced a front end that was as selective as fixed frequency designs, yet could cover the entire 25 MHz range. The next step to improve the front end was to use good old fashioned "brute force."

HIGH CURRENT LOW NOISE AMPLIFIERS

The gain stages in the front end use some rather special transistors in a feedback regulated high current circuit that combine three parameters that are generally at odds with one another. These are: low noise, low gain and relatively high power. It is easy to understand the advantages of low noise and high power capability but why is low gain desirable? The answer is that in a receiver, low gain allows the front end to handle stronger RF signals without output overload, which is "increased headroom," so to speak. The result of a design that takes all three of these parameters into consideration at once, is a low noise RF amplifier with a sensitivity rating equal or better than the best conventional design with a hundred times less susceptibility to intermodulation interference.

Combining the high power gain stages with the tracking front end produces a receiver that is unusually immune to single and multiple interfering signals close to the operating frequency and in addition strongly rejects signals that are much farther away.

DOUBLE BALANCED DIODE MIXERS

In all wireless receivers, a mixer is used to convert the carrier frequency to the IF frequency where most of the filtering and gain in the receiver takes place. After doing all the right things in the

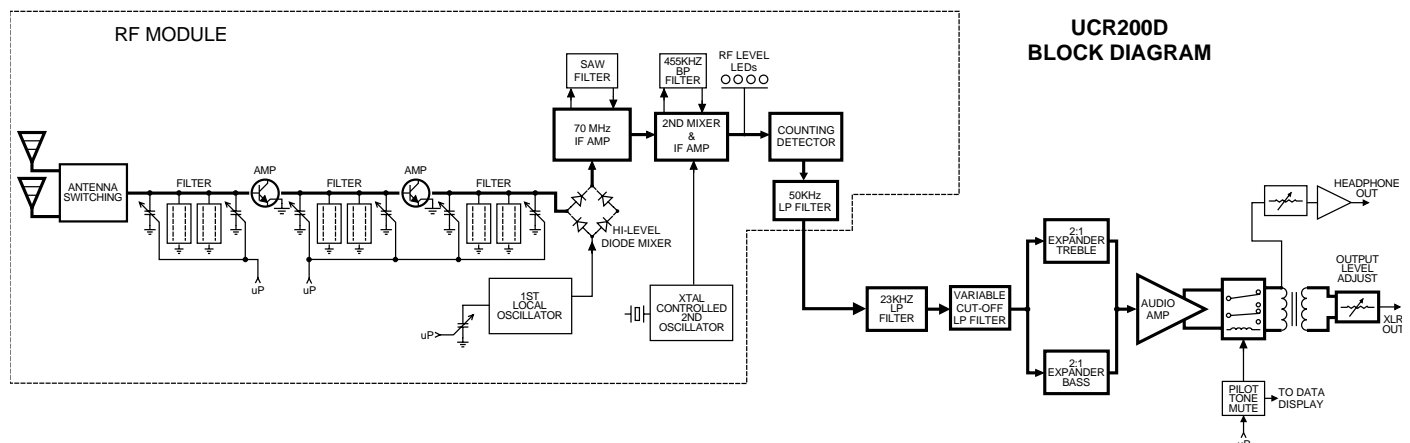

GENERAL TECHNICAL DESCRIPTION

front end, it would be a shame to waste the performance with a second rate mixer. In other designs that is exactly what happens since mediocre mixers cause more intermodulation problems than mediocre front ends. The only solution was a high power, double balanced diode mixer driven by a local oscillator with more output power than most wireless transmitters (50 mW). The mixer in the UCR200D produces output at only the sum and difference signals, with minimal spurious signals. This mixer offers a very high overload threshold and a high degree of isolation between ports. The IF output of this mixer is at 71 MHz which is unusually high for a wireless receiver. This high frequency was chosen to increase the image rejection in the front end to as high or a higher level than our fixed frequency designs. The mixer is followed by high current, low noise amplifiers and SAW filters to preserve the superior RF performance.

SURFACE ACOUSTIC WAVE FILTER

The UCR200D is unique in that it uses state of the art SAW filters in each IF section. The SAW filters are the only filter that can combine sharp skirts, constant group delay, and wide bandwidth in one filter. Though expensive, this special type of filter allows us to follow the basic receiver rule of doing the primary filtering as early as possible, at as high a frequency as possible and before high gain is applied to the signal. Since these filters are made of quartz, they are very temperature stable. Conventional LC filters at these frequencies don't begin to perform as well and in addition would drift unacceptably in the elevated temperatures of an equipment rack. After following the rule in a rigorous way, and due to the sharp filtering action of the SAW filters, the 71MHz signal is converted to the low frequency of 455 kHz. Lots of gain is then applied in a conventional IC and the signal is then converted to audio. 455 kHz is very unconventional for a second IF in a wide deviation (± 75 kHz) system. We chose to use 455 kHz to obtain an outstanding AM rejection figure over a very wide range of signal strengths and to produce an excellent noise improvement at low signal strengths (capture ratio). To use an IF at 455 kHz requires an unusual circuit to convert the IF to audio.

DIGITAL PULSE COUNTING DETECTOR

The UCR200D receiver uses an advanced digital pulse detector to demodulate the FM signal, rather than a conventional quadrature detector. The common problem with quadrature detectors is thermal drift, particularly those that operate at higher frequencies like 10.7 MHz. Though the quadrature detectors may work well at room temperature, if they are not carefully compensated, they will produce amplitude changes and audio distortion in the elevated temperatures of an equipment rack. Some manufacturers try to get around the problem by tuning their systems at higher temperatures after they've been on for some time. This just means that for the first hours in a cool room the receiver is well out of specification or after a few hours in a hot rack.

The UCR200D design presents an elegantly simple, yet highly effective solution to this age old problem. The UCR200D detector basically works like this: A stream of precision pulses is generated at 455KHz locked to the FM signal coming from the 455 kHz IF section. The pulse width is constant, but the timing between pulses varies with the frequency shift of the FM signal. The integrated voltage of the pulses within any given time interval

varies in direct proportion to the frequency modulation of the radio signal. Another way of describing it is that as the FM modulation increases the frequency, the circuit produces more pulses and as the modulation decreases the frequency, the circuit produces fewer pulses. More pulses produces a higher voltage and fewer pulses a lower voltage. The resultant varying voltage is the audio signal.

This type of detector eliminates the traditional problems with quadrature detectors and provides very low audio distortion, high temperature stability and stable audio level. The counting detector also adds additional AM rejection, in addition to the limiting in the IF section. The amplitude of the pulses is constant, so level differences in the IF signal do not affect the pulse.

TRI MODE DYNAMIC FILTER

The audio signal is passed through a "dynamic noise reduction circuit". The cutoff frequency of this filter is varied automatically by measuring the amplitude and frequency of the audio signal and the quality of the RF signal. The audio bandwidth is held only to that point necessary to pass the highest frequency audio signal present at the time. If the RF level is weak, then the filter becomes more aggressive. This results in a dramatic reduction of "hiss" at all times. During passages with a high frequency content, this filter gets completely "out of the way" and passes the signal with no decrease in high-frequency response. Keep in mind that if hiss is added to a signal, there is a psycho acoustic effect that makes the sound seem brighter. The other side of this is that if hiss is removed from a signal it will sound duller. Basically the ear's detection apparatus is pre-sensitized to high frequency sounds by small amounts of high frequency hiss. Consider this effect when making a judgment about the sound quality of various wireless systems and this particular filter. We have satisfied ourselves through elaborate tests that this filter is totally transparent.

PILOT TONE MUTE (SQUELCH)

The 200 system utilizes a separate ultrasonic tone modulation of the basic carrier to operate the receiver squelch. In the transmitter, a 32kHz tone is injected into the audio signal path just after the compandor. The supersonic pilot tone is filtered out of the audio signal immediately after the detector in the receiver so that it does not influence the compandor or various gain stages.

The basic benefit of the pilot tone squelch system is that the receiver will remain squelched (muted) until it receives the pilot tone from the matching transmitter, even if a strong RF signal is present on the carrier frequency of the system. Once a pilot tone is received, the receiver will remain open during all signal conditions.

The mute circuit drives a relay which physically disconnects the output amplifier from the output. This provides complete muting of the audio and the noise. The pilot tone function may be bypassed with the Pilot Tone Disable switch (located on the front panel.) When the pilot tone has been disabled with this switch, the Pilot LED will glow red and the MOD function of the LED bargraph meter on the front panel is disabled. The Pilot LED on the front panel will glow green when the pilot tone has enabled the receiver audio output.

GENERAL TECHNICAL DESCRIPTION

OUTPUT LEVEL ADJUST AND RANGE SWITCH

The front panel Output control will adjust the audio output within the range set by the Lo/Mid/Hi range switch (located on the back panel.) In the Lo position the adjustment range is from -50dBm to -20dBm , the Mid position (center) allows an adjustment from -30dBm to 0dBm , and the Hi position sets the audio output to a fixed $+8\text{dBm}$ with no front panel control.

POWER SUPPLY

The UCR200D may be operated from the supplied CH20 adapter, or from an external 12 to 18 VDC source. The power supply has a built in Poly-Fuse to protect the unit. This fuse is self healing by simply disconnecting the power supply for about 15 seconds.

FRONT PANEL CONTROLS AND FUNCTIONS

POWER LED

When lit, this LED indicates that power is applied to the UCR200D and adequate voltage is present to operate the unit.

PILOT LED

The audio output muting (squelch) function of the UCR200D is controlled by a 32kHz tone modulation of the RF carrier. The audio output is muted until this tone is present. This green LED will remain on as long as the receiver audio is enabled by the pilot tone.

TRANSMITTER MOD LEVEL METER

When the meter function switch is in the Mod position, the modulation (audio level) of the incoming signal is indicated by a fast responding LED strip. The strip is calibrated in 6dB steps over an expanded scale (54dB) which provides an extremely accurate visual "picture" of the signal dynamics, even at a distance away from the receiver. Audio signal peaks easily exceed the response time of VU meters, however, the LED strip is fast enough to track even brief transients.

RF LEVEL INDICATORS

With the meter function switch in the RF position, the LED strip indicates the level of the incoming RF signals. The LED strips are calibrated to provide accurate indications from 1uV to 1mV. The LEDs are highly visible from a distance, making antenna set up more accurate. The LED strip is especially useful in "troubleshooting" difficult antenna installations.

POWER SWITCH (and PILOT DISABLE)

This slide switch, and its corresponding LED indicator, switches the receiver from Off to On with Pilot enabled or ON with Pilot disabled. The pilot LED will glow green when pilot tone is

present. With the switch in the "ON (Pilot Off)" position, the LED will glow red. At turn on and off there is a delay built into the receiver to allow various stages to stabilize before the audio output is activated. This will prevent an audio "thump" when powering up the receiver.

PILOT TONE DISABLE

The Power switch on the front panel is the Pilot Tone Disable. This is a three position switch. The position toward the right (as seen looking straight at the front panel) is the normal operating position and allows the pilot tone to enable or disable the receiver audio output. The other position, toward the left, will disable the pilot tone action and will cause the receiver audio output to always be enabled, even in the absence of a transmitter signal. This position is only used for troubleshooting and should never be set during actual use. When the pilot tone is disabled with this switch, the Mod meter on the front panel is also disabled.

AUDIO OUTPUT LEVEL CONTROL

The front panel Audio Output Level control will adjust the audio output within the range set by the Lo/Mid/Hi range switch (located on the rear panel.) In the Low position the adjustment range is from -50dBm to -20dBm, the High position (center) allows an adjustment from -30dBm to 0dBm, and the Fixed position sets the audio output to a fixed +8dBm with no front panel control.

ANTENNA CONNECTORS

These are standard 50 Ohm BNC type jacks for the RF input to the receiver. The left jack is the main antenna (0) and the right jack is for the diversity antenna (180).

ANTENNA PHASE LEDs

These two LEDs labeled "0" and "180" show the phase difference of the signals being received at the two antennas.

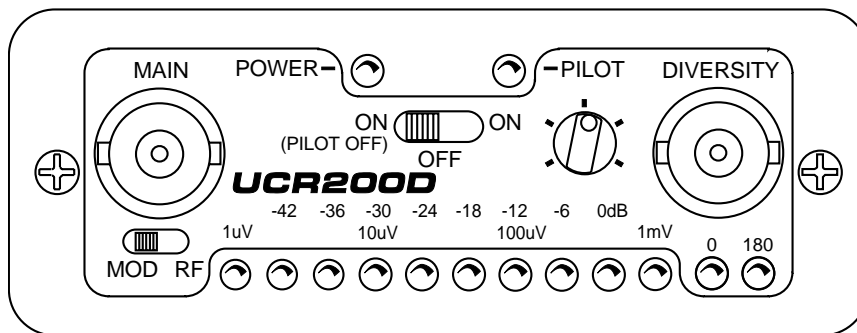

REAR PANEL CONTROLS AND FUNCTIONS

DC IN JACK

The UCR200D can be powered from external 12 to 18 Volts DC applied directly to this jack, or conventional 110 VAC sources via the supplied CH20 adapter. The UCR200D is protected from reverse polarity conditions which prevents damage if a positive ground power source is applied. The center pin of this jack is POSITIVE. This power connector is threaded to allow the plug to be locked in preventing accidental pull-out.

AUDIO OUTPUT XLR JACK

This jack is a standard 3 pin XLR connector. For balanced applications, Audio High is on pin 2, audio Low is on pin 3, and audio Common is pin 1. For unbalanced use, the signal is developed between pin 2 (Audio High) and pin 1 (Audio Common or Ground.) It's not necessary or desirable to ground pin 3. (The output is balanced and center tapped.)

MONITOR

This is an audio output to drive a wide variety of different types of headphones. It is also usable as a second high quality audio output to drive recorders or external audio devices. The level at this jack is independantly adjustable with the associated knob.

RANGE SWITCH

The audio output range switch is located on the rear panel and is the switch nearest the front panel. This switch controls the range of adjustment of the front panel Audio Output control. In the Low position the adjustment range is from -50dBm to -20dBm , the High position allows an adjustment from -30dBm to 0dBm , and the Fixed position sets the audio output to a fixed $+8\text{dBm}$ with no front panel control.

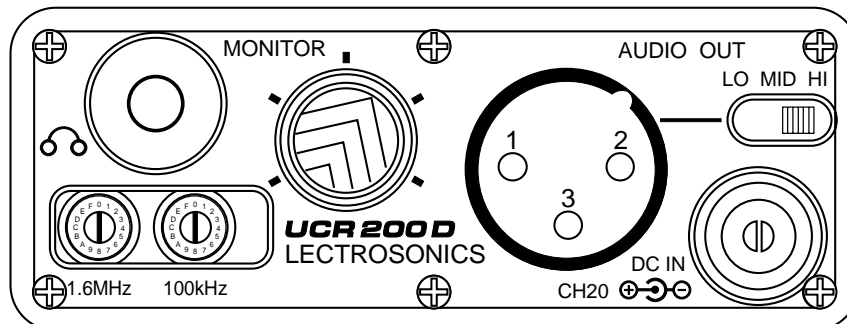

ANTENNA USE AND PLACEMENT

There are two remote antenna assemblies included with this receiver. Position the antennas at least three or four feet apart and so that they are not within 3 or 4 feet of large metal surfaces. If this is not possible, try to position the antennas so that they are as far away from the metal surface as is practical. It is also good to position the receiver so that there is a direct "line of sight" between the transmitter and the receiver antenna. In situations where the operating range is less than about 100 feet, the antenna positioning is much less critical. The antennas can also be configured with one whip mounted directly onto the rear panel of the UCR200D receiver, and the other one mounted remotely.

A wireless transmitter sends a radio signal out in all directions. This signal will often bounce off nearby walls, ceilings, etc. and a strong reflection can arrive at the receiver antenna along with the direct signal. If the direct and reflected signals are out of phase with each other a cancellation may occur. The result would be a "drop-out." A drop-out sounds like either audible noise (hiss), or in severe cases, may result in a complete loss of the carrier and the sound when the transmitter is positioned in certain locations in the room. A drop-out normally sounds like "hiss" or a "swishing" sound. Moving the transmitter even a few inches will change the

sound of the hum or hiss, or eliminate it. A drop-out situation may be either better or worse as the crowd fills and/or leaves the room, or when the transmitter or receiver is operated in a different location.

The UCR200D receiver offers a sophisticated diversity design which overcomes drop-out problems in almost any imaginable situation. In the event, however, that you do encounter a dropout problem, first try moving the antenna at least 3 or 4 feet from where it was. This may alleviate the drop-out problem on that antenna. If drop-outs are still a problem, try moving the antenna to an entirely different location in the room or moving the antennas in closer to the transmitter location.

Lectrosonics transmitters radiate power very efficiently, and the receivers are very sensitive. This reduces drop-outs to an insignificant level. If, however, you do encounter drop-outs frequently, call the factory or consult your dealer. There is probably a simple solution.

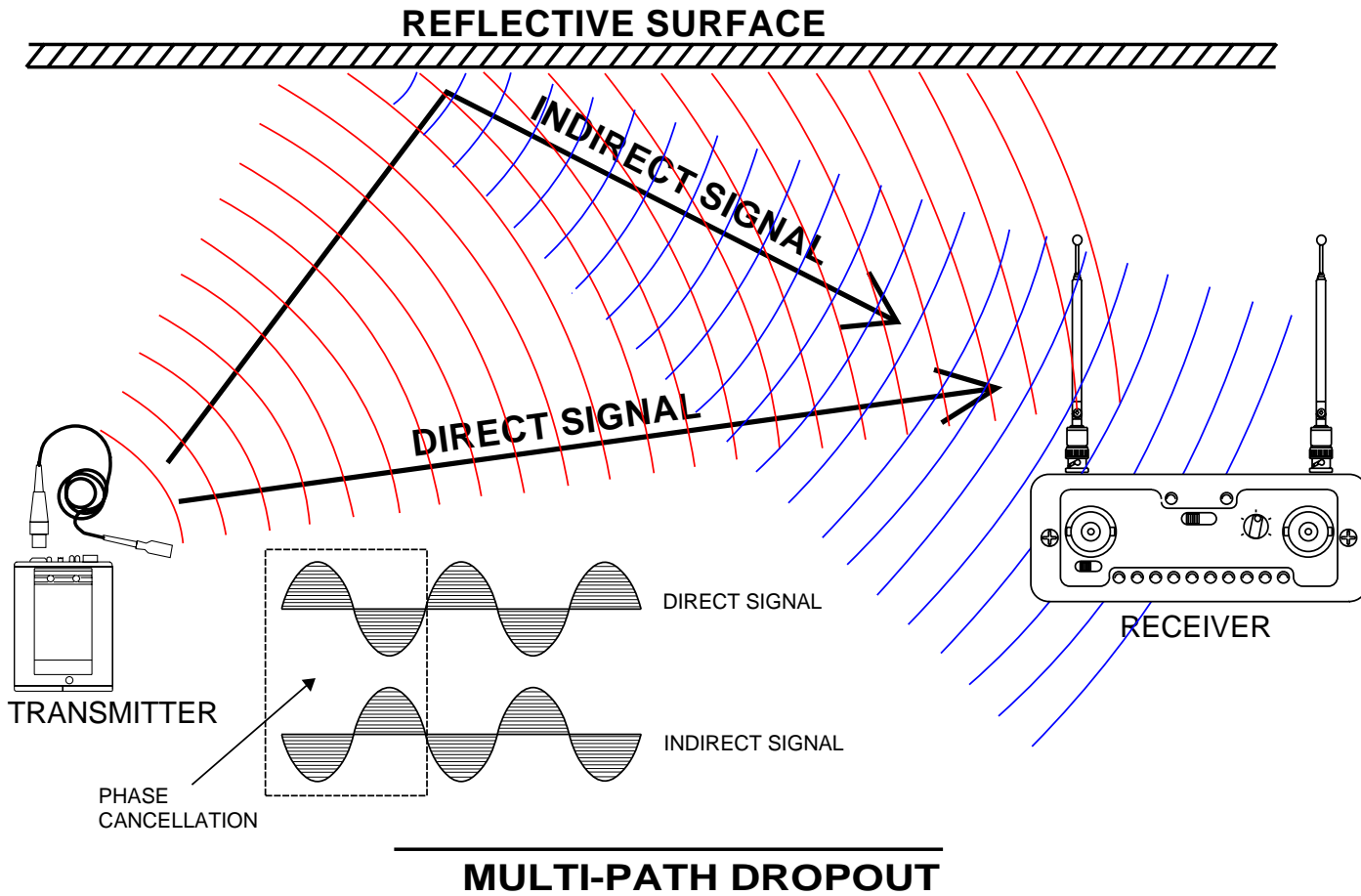

INSTALLATION AND OPERATING INSTRUCTIONS

1. Connect the power cord.
2. Attach the antennas.
3. Connect the audio cable to the audio output XLR.
4. Set the front panel Audio Output Level control to minimum and set the Power switch to ON (right position.) Check to see that the front panel Power LED lights up.
5. Adjust the transmitter gain. **THIS IS PERHAPS THE MOST IMPORTANT STEP IN THE SET UP PROCEDURE.** See your transmitter manual (Operating Instructions section) for details on how to adjust the transmitter gain. In general, adjust the transmitter gain so that the voice peaks will cause the 0dB LED on the front of the receiver to light on the loudest peak audio levels. This will result in the best possible signal to noise ratio for the system without causing overload distortion.
6. Adjust the Audio Output control according to the type of input on your equipment. The Range switch sets the adjustment range of the front panel Audio Output control and has three positions.
 - Low:** The adjustment range is from -50dBm to -20dBm .
 - Mid:** Allows an adjustment from -30dBm to 0dBm
 - High:** Sets the audio output to a fixed $+8\text{dBm}$ with no front panel control.

The input levels of different cameras, VCRs, and PA equipment vary, which may require that you set the Audio Output control to an intermediate position. Try different settings and listen to the results. If the output of the receiver is too high, you may hear distortion or a loss of the natural dynamics of the audio signal. If the output is too low, you may hear steady noise (hiss) along with the audio. The UCR200D audio output is designed to drive any audio input device from microphone level to $+8\text{dBm}$ line level.

Note:

When using the $+8\text{ dBm HI}$ position of the output range switch, do not ground pin 2 or pin 3 of the XLR output! The output impedance is only 50 Ohms (unbalanced) when in the HI position and this is not enough to isolate the audio amplifier from a short to ground. Distortion will result.

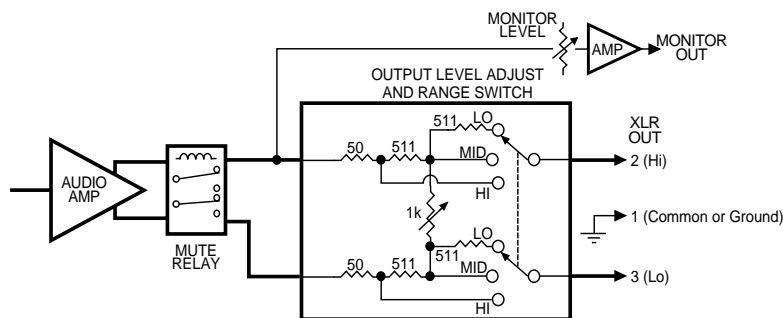

UCR200D Simplified Audio Output Circuit

UCR200D REPLACEMENT PARTS and ACCESSORIES

<u>Part No.</u>	<u>Description</u>
32251	UHF Rubber Duck Antenna, straight connector
35753	Velcro mounting strips
CH20	Zippered, padded vinyl system pouch
PS200	AC Power Adapter, 110V input, 12VDC output
21586	Power supply cable locking plug on one end and a Hirose plug on the other for hookup to a camera.
	Power supply cable with locking plug on one end and pigtail leads on the other

FREQUENCY BLOCKS AND RANGES

The table below lists the factory designated frequency ranges available for the UCR200D receiver. For convenience, the table includes information about the UM200B belt-pack transmitter antennas as well.

Each UCR200D receiver is built to cover a pre-selected range of frequencies (a "block") as shown below. The receiver will tune to any of 256 different frequencies within this factory assigned block.

The UCR200D UHF Receiver antennas (model A8U) are color coded to indicate the frequency block that they operate within.

The length of the antenna varies with the frequency block. The actual length of the antenna is not as critical as it might appear in the table below. The usable bandwidth of the A8U antennas are +/- 50 MHz from the center frequency, so it is acceptable to use an antenna from an adjacent block above or below the operating frequency.

The color of the antenna sleeve is in keeping with standard resistor value color codes for the second digit of the block number. Block 23 is not used since it covers a 608 to 614 MHz band that is not allocated for use with wireless microphones.

BLOCK	FREQUENCY RANGE	ANT SLEEVE COLOR	ANTENNA WHIP LENGTH
21	537.600 - 563.100	Brown	4.74"
22	563.200 - 588.700	Red	4.48"
23	588.800 - 614.300	Orange	4.24"
24	614.400 - 639.900	Yellow	4.01"
25	640.000 - 665.500	Green	3.81"
26	665.600 - 691.100	Blue	3.62"
27	691.200 - 716.700	Violet (Pink)	3.46"
28	716.800 - 742.300	Grey	3.31"
29	742.400 - 767.900	White	3.18"
30	768.000 - 793.500	Orange/Black	3.08"
31	793.600 - 819.100	Orange/Brown	2.99"
32	819.200 - 844.700	Orange/Red	2.92"
33	844.800 - 865.000	Orange/Orange	2.87"

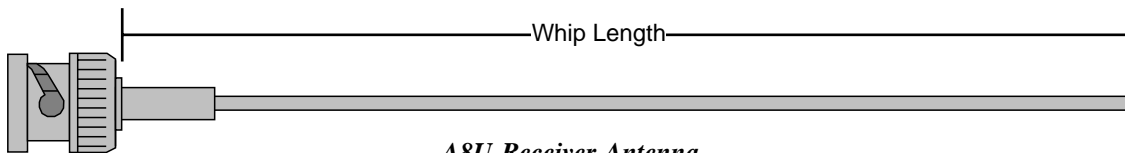

A8U Receiver Antenna

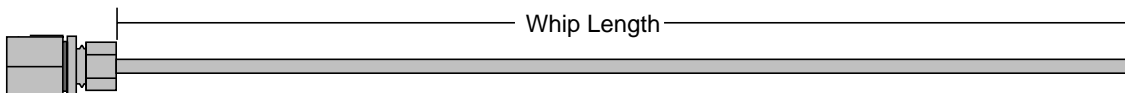

A6U Transmitter Antenna

TROUBLESHOOTING

POWER SUPPLY AND FUSE

LEDs not lit or dimly lit

- External power supply disconnected or inadequate.
- Main power supply fuse tripped. Turn the receiver off, remove the cause of the overload and turn the receiver back on.
- Wrong polarity power source. The external DC input requires POSITIVE to be on the center pin.

PILOT TONE SQUELCH

The PILOT indicator lamp on the front panel glows green to indicate that the audio has been turned on at the transmitter, and that the audio output on the receiver is enabled. When the lamp is on, the audio is enabled. When the lamp is off, the audio is muted.

PILOT lamp on, but no sound

- Audio output cable bad or disconnected.
- Audio Output level set too low.

PILOT lamp does not come on when transmitter audio switch is turned on

- It takes several seconds for the relay to actuate the PILOT lamp. Turn the transmitter power and audio switches on and wait 3 to 5 seconds for the lamp to come on.

Normal audio on output but the Mod meter on the front panel is not working.

- The Power switch may be in the “ON (Pilot Disable)” position. This front panel switch should be in the right-most position.

ANTENNAS AND RF SIGNAL STRENGTH

RF Level is weak.

- Antenna is disconnected or there is a bad connection
- Antenna may need to be moved or re-oriented
- Improper length of antenna, or wrong antenna. UHF whip antennas are generally about 3 to 5 inches long. UHF helical antennas may be shorter, but are often less efficient.

AUDIO SIGNAL QUALITY

Poor signal to noise ratio

- Transmitter gain set too low
- Noise may not be in wireless system. Mute the audio signal at the transmitter and see if noise remains. If the noise remains, then turn the power off at the transmitter and see if it remains. If the noise is still present, then the problem is not in the transmitter.
- If noise is still present when the transmitter is turned off, try lowering the audio output level on the UCR200D rear panel and see if the noise lowers correspondingly. If the noise remains, the problem is not in the receiver.
- Receiver output is too low for the input of the device it is feeding. Try increasing the output level of the UCR200D and lowering the input gain on the device the UCR200D is feeding.

Distortion

- Transmitter input gain too high. Check and/or re-adjust input gain on transmitter according to the LEDs on the transmitter and then verify the setting with the transmitter audio level LED strip on the UCR200D front panel.
- Audio output level too high for the device the UCR200D is feeding. Lower the output level of the UCR200D.

SERVICE AND REPAIR

If your system malfunctions, you should attempt to correct or isolate the trouble before concluding that the equipment needs repair. Make sure you have followed the setup procedure and operating instructions. Check out the interconnecting cords and then go through the TROUBLE SHOOTING section in the manual

We strongly recommend that you **do not** try to repair the equipment yourself and **do not** have the local repair shop attempt anything other than the simplest repair. If the repair is more complicated than a broken wire or loose connection, send the unit to the factory for repair and service. Don't attempt to adjust any controls inside the units. Once set at the factory, the various controls and trimmers do not drift with age or vibration and never require readjustment. **There are no adjustments inside that will make a malfunctioning unit start working.**

LECTROSONICS service department is equipped and staffed to quickly repair your equipment. In-warranty repairs are made at no charge in accordance with the terms of the warranty. Out of warranty repairs are charged at a modest flat rate plus parts and shipping. Since it takes almost as much time and effort to determine what is wrong as it does to make the repair, there is a charge for an exact quotation. We will be happy to quote approximate charges by phone for out of warranty repairs.

RETURNING UNITS FOR REPAIR

You will save yourself time and trouble if you will follow the steps below:

- A.** DO NOT return equipment to the factory for repair without first contacting us by letter or by phone. We need to know the nature of the problem, the model number and the serial number of the equipment. We also need a phone number where you can be reached 8 am to 4 pm (Mountain Standard Time).
- B.** After receiving your request, we will issue you a return authorization number (R.A.). This number will help speed your repair through our receiving and repair departments. The return authorization number must be clearly shown on the outside of the shipping container.
- C.** Pack the equipment carefully and ship to us, shipping costs prepaid. If necessary, we can provide you with the proper packing materials. UPS is usually the best way to ship the units. Heavy units should be "double-boxed" for safe transport.
- D.** We also strongly recommend that you insure the equipment, since we cannot be responsible for loss of or damage to equipment that you ship. Of course, we insure the equipment when we ship it back to you.

Mailing address:

Lectrosonics, Inc.
PO Box 15900
Rio Rancho, NM 87174
USA

Shipping address:

Lectrosonics, Inc.
581 Laser Rd.
Rio Rancho, NM 87124
USA

Telephones:

Regular: (505) 892-4501
Toll Free (800) 821-1121
FAX: (505) 892-6243

World Wide Web: <http://www.lectrosonics.com>

Email: sales@lectrosonics.com

SPECIFICATIONS AND FEATURES

Operating Frequencies:	537.600 to 588.700 MHz; 614.400 to 793.500 MHz
Frequency Adjustment Range:	25.5 MHz
Receiver Type:	Dual conversion, superheterodyne, 71MHz and 455kHz
Frequency Stability:	± 0.002 %
Front end selectivity:	>22 dB at ± 4 MHz
Sensitivity	
20 dB Sinad:	0.8 uV (-109 dBm), A weighted
60 dB Quieting:	1.0 uV (-107 dBm), A weighted
Squelch quieting:	Greater than 125 dB
AM rejection:	Greater than 60 dB, 2 uV to 1 Volt (Undetectable after processing)
Modulation acceptance:	>90 kHz
Image and spurious rejection:	>100 dB
Third order intercept:	+12 dBm
Diversity method:	Phased antenna diversity
FM Detector:	Digital Pulse Counting Detector operating at 455kHz
Antenna inputs:	Dual BNC female; 50 Ohm impedance
Audio outputs	
Rear Panel XLR:	Nominal 600 Ohm balanced, three level ranges: LO - Variable -50 dBm to -20 dBm MID - Variable -30 dBm to 0 dBm HI - +8 dBm line level.
Monitor:	0.5VRMS, 50 Ohm load
Front Panel Controls and Indicators:	Main and Diversity antenna BNC connectors; Power on/pilot disable/off switch and LED; Dual function pilot tone LED; Dual function 10 segment display for RF signal level and transmitter audio level display; Two LEDs (0 / 180) to indicate the antenna phase.
Rear Panel Controls and features:	XLR audio output jack; Monitor output jack and level control; Frequency selection switches; External DC input; Audio level range select switch.
Power Options:	12VDC, 4.8W (400mA)
Weight:	12 ozs
Dimensions:	3.2" wide x 1.22" high x 5.1" deep

Typical System Frequency Response

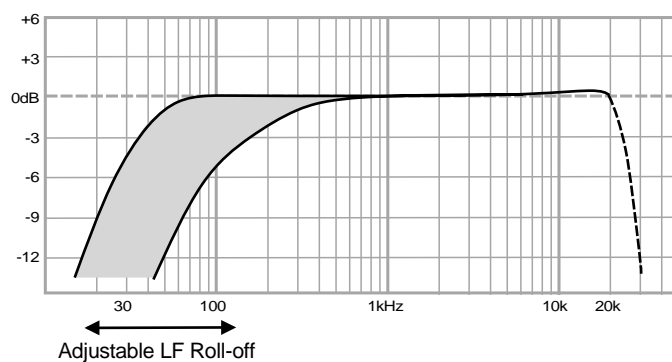

Typical System THD + Noise

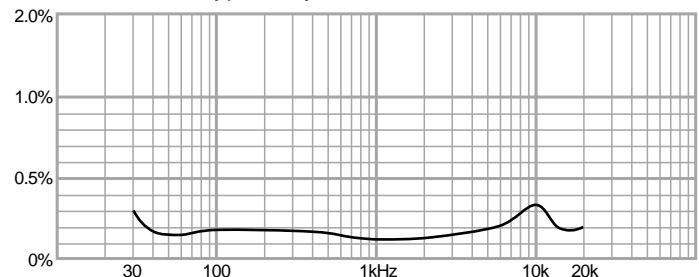

Specifications subject to change without notice.



LIMITED ONE YEAR WARRANTY

The equipment is warranted for one year from date of purchase against defects in materials or workmanship provided it was purchased from an authorized dealer. This warranty does not cover equipment which has been abused or damaged by careless handling or shipping. This warranty does not apply to used or demonstrator equipment.

Should any defect develop, we will, at our option, repair or replace any defective parts without charge for either parts or labor. If we cannot correct the defect in your equipment, we will replace it at no charge with a similar new item. We will pay for the cost of returning your merchandise to you.

This warranty applies only to items returned to us, shipping costs prepaid, within one year from the date of purchase.

This warranty gives you specific legal rights. You may have additional legal rights which vary from state to state.

LECTROSONICS, INC.

581 LASER ROAD
RIO RANCHO, NM 87124 USA

Ph: (800)821-1121 or (505) 892-4501

Fax: (505) 892-6243

Email: sales@lectrosonics.com

Web: www.lectrosonics.com

September 23, 1999